



KEMENTERIAN PENDIDIKAN MALAYSIA

Jabatan Pendidikan Negeri Melaka

#jpnmelakajenamakerajaan1

PROJEK KM²

@ KEMENJADIAN MURID MELAKA

MODUL DLP

KSSM

**MATEMATIK
TAMBAHAN**

TINGKATAN 4

2021

FASA 3

NAMA MURID :

NAMA KELAS :

NAMA GURU :



KEMENTERIAN PENDIDIKAN MALAYSIA
Jabatan Pendidikan Negeri Melaka
#jpnmelakajenamakerajaanno1

**SENARAI NAMA AHLI PANEL PEMBINA MODUL KSSM @ KM²
MATA PELAJARAN MATEMATIK TAMBAHAN KSSM TINGKATAN 4**

NAMA GURU PANEL	NAMA SEKOLAH
WAN MALINA BINTI ABDULLAH (Guru Sumber)	SMK GAJAH BERANG
SITI SARAH BINTI OTHMAN (Guru Sumber)	SBP INTEGRASI SELANDAR
FOO YEE CHOW	SMK CANOSSA CONVENT
WILLIAM TAN WEI LONG	SMK SIMPANG BEKOH
ANISAH BINTI ISMAIL	SMK SERI TANJUNG
BALQIS BINTI MUSTAFFA	SMK SERI TANJUNG
CHOCK TOK HENG	SMK DATUK BENDAHARA
MOHD ZAHARI BIN ARIFFIN	SMK TELOK MAS
CHENG BOON HAU	SMK TINGGI ST DAVID
TEH ENG AUN	SMK PEREMPUAN METHODIST
NOOR SUHADA BINTI MOHD ASRI	SMK ST FRANCIS
LEE HONG CHIN	SM SAINS MUZAFFAR SYAH
SAIFUL AZIZI BIN AHYAK	SMK KEM TERENDAK
AZAAED BIN AHMAD RADIN	SBP INTEGRASI SELANDAR

EDISI PERTAMA 2021

CETAKAN JABATAN PENDIDIKAN MELAKA

“PENDIDIKAN BERKUALITI, INSAN TERDIDIK, NEGARA SEJAHTERA”

3	3.1 Sistem Persamaan Linear dalam Tiga Pemboleh Ubah 3.2 Persamaan Serentak yang Melibatkan Satu Persamaan Linear dan Satu Persamaan Tak Linear.
---	-----------------------------------------------------------------------------------------------------------------------------------------------------

BAB 3 : SISTEM PERSAMAAN CHAPTER 3 : EQUATION SYSTEM	
3.1 ; Sistem Persamaan Linear dalam Tiga Pemboleh Ubah 3.1 : Linear Equation System in Three Variables	
<p>Contoh 1: Example 1:</p> <p>Selesaikan persamaan dibawah; Solve the equation below;</p> $x + 2y - 3z = 0, \quad 2x - y + z = 3 \quad \text{dan} \quad -3x + 2y - 2z = -5$	
<p>Kaedah 1: Kaedah Penghapusan Method 1 : Elimination Method</p> <p>Pilih mana-mana 2 persamaan Choose any 2 equations. 1</p> $\begin{array}{l} x + 2y - 3z = 0, \quad \text{----- Persamaan 1} \\ 2x - y + z = 3 \quad \text{----- Persamaan 2} \end{array}$ <p>Samakan mana-mana pekali dalam kedua-dua persamaan tersebut (contohnya pekali x) dengan operasi darab. 2 Equalize any quotation in both equations (example quation for x) using multiplication.</p> $\begin{array}{l} (x + 2y - 3z = 0,) \times 2 \\ 2x + 4y - 6z = 0 \quad \text{-----Persamaan 3} \\ 2x - y + z = 3 \quad \text{----- Persamaan 2} \end{array}$ <p>Hapuskan pembolehubah x menggunakan operasi penolakan. 3 Eliminate variable x using substraction</p> $\begin{array}{r} 2x + 4y - 6z = 0 \\ \underline{2x - y + z = 3} \end{array} \left. \vphantom{\begin{array}{r} 2x + 4y - 6z = 0 \\ 2x - y + z = 3 \end{array}} \right\} \begin{array}{c} \square \\ - \end{array}$ $5y - 7z = -3 \quad \text{-----persamaan 4}$ <p>4</p> <p>Ulangi langkah 1 hingga 3 menggunakan 2 persamaan yang lain. 4 Repeat step 1 until 3 using any other 2 equations</p> $\begin{array}{l} x + 2y - 3z = 0 \quad \text{-----Persamaan 1} \\ -3x + 2y - 2z = -5 \quad \text{-----Persamaan 5} \\ \underline{-3x - 6y + 9z = 0} \quad \text{-----Persamaan 6} \\ \hspace{10em} (\text{Persamaan 1 X } (-3)) \\ 8y - 11z = -5 \quad \text{-----Persamaan 7} \end{array}$	<p>Kaedah 2 : Kaedah Penggantian Method 2 : Subtituition Method</p> <p>Ungkapkan 1 pembolehubah kepada pembolehubah yang lain (contoh Persaman 1) Express 1 variable into another terms (Example equation 1)</p> $x = 3z - 2y \quad \text{-----Persamaan 4} \quad \text{1}$ <p>Gantikan $x = 3z - 2y$ ke dalam persamaan 2 Subtitute $x = 3z - 2y$ into equation 2 2</p> $\begin{array}{l} 2(3z - 2y) - y + z = 3 \\ 6z - 4y - y + z = 3 \\ 7z - 5y = 3 \quad \text{---Persamaan 5} \end{array}$ <p>Ungkapkan y dalam sebutan z untuk persamaan 5 Express y in term of z for equation 5 3</p> $y = \frac{3-7z}{-5}$ <p>Gantikan $x = 3z - 2y$ ke dalam persamaan 3 Subtitute $x = 3z - 2y$ into equation 3 4</p> $\begin{array}{l} -3(3z - 2y) + 2y - 2z = -5 \\ -9z + 6y + 2y - 2z = -5 \\ 8y - 11z = -5 \quad \text{Persamaan 6} \end{array}$ <p>Gantikan $y = \frac{3-7z}{-5}$ ke dalam persamaan 6 Subtitute $y = \frac{3-7z}{-5}$ into equation 6 5</p> $8\left(\frac{3-7z}{-5}\right) - 11z = -5$

<p style="text-align: center;">(Pers 5 – Pers. 6)</p> <p>Ulangi langkah 1 hingga 3 untuk menghapuskan 1 lagi pembolehubah dari persamaan 4 dan persamaan 7</p> <p>Repeat step 1 until 3 to eliminate another variable from equation 4 and equation 7.</p> <p> $5y - 7z = -3$ -----Persamaan 4 $8y - 11z = -5$ -----Persamaan 7 </p> <p>Samakan pekali y dengan mendarabkan persamaan 4 dengan 8 dan persamaan 7 dengan 5.</p> <p>Equalize quotation y by multiply equation 4 with 8 and equation 7 with 5.</p> <p> $40y - 56z = -24$ -----Persamaan 4 X 8 $40y - 55z = -25$ -----Persamaan 7 X 5 </p> <p>Hapuskan pembolehubah y dengan melakukan operasi tolak.</p> <p>Eliminate variable y by using subtraction method.</p> <div style="border: 1px solid black; padding: 5px; margin: 5px 0;"> $\begin{array}{r} 40y - 56z = -24 \\ 40y - 55z = -25 \\ \hline -z = 1 \\ Z = -1 \end{array}$ </div> <p>Gantikan z = -1 dalam persamaan 4 atau persamaan 7</p> <p>Substitute z = -1 into equation 4 or equation 7</p> <p> $5y - 7(-1) = -3$ $y = \frac{-3+7(-1)}{5} = -2$ </p> <p>Gantikan z = -1 dan y = -2 dalam persamaan 1</p> <p>Substitute z = -1 and y = -2 into equation 1</p> <p> $x + 2(-2) - 3(-1) = 0$ $x = 1$ </p>	<p> $\frac{24-56z}{-5} - \frac{-55z}{-5} = -5$ $24 - 56z + 55z = 25$ $-z = 25 - 24$ $Z = -1$ </p> <p>Gantikan z = -1 ke dalam persamaan 6</p> <p>Substitute z = -1 into equation 6</p> <p> $8y - 11(-1) = -5$ $y = \frac{-5+11(-1)}{8} = -2$ </p> <p>Gantikan z = -1 dan y = -2 dalam persamaan 1</p> <p>Substitute z = -1 and y = -2 into equation 1</p> <p> $x + 2(-2) - 3(-1) = 0$ $x = 1$ </p>
-------------------------------------------------------------------------------------------------------------------------------------------------------------------------------------------------------------------------------------------------------------------------------------------------------------------------------------------------------------------------------------------------------------------------------------------------------------------------------------------------------------------------------------------------------------------------------------------------------------------------------------------------------------------------------------------------------------------------------------------------------------------------------------------------------------------------------------------------------------------------------------------------------------------------------------------------------------------------------------------------------------------------------------------------------------------------------------------------------------------------------------------------------------------------------------------------------------------------------------------------------------------------------------------------------------------------------------------------------------------------------------------------------------------	---------------------------------------------------------------------------------------------------------------------------------------------------------------------------------------------------------------------------------------------------------------------------------------------------------------------------------------------------------------------------------------------------------------------------------------------------------------------------------------------------------------------

LATIHAN:
EXERCISE:

1. Cari nilai x,y dan z bagi setiap persamaan serentak berikut.
Find the value of x, y and z for each simultaneous equations.

- a) $2x + 4y - 3z = 0$, $2x - y + z = 3$, $3x - 2y + 2z = 5$
- b) $x + y - z = -1$, $2x - 3y + z = -4$, $3x - y + z = -1$
- c) $2x - 3y + z = -4$, $4x + y - z = 4$, $3x + 2y - z = 4$
-0.5]

[x=1, y=2 z=3]
[x=-1, y= 1 z=1]
[x = 0.5, y = 1.5, z =

2. Ali, Belle dan Cheng bercadang membeli pen, pensel dan pembaris dari satu kedai yang sama untuk peralatan sekolah mereka. Ali membeli sebatang pen, 3 batang pensel dan 2 batang pembaris dengan harga RM 4. Belle pula membeli 2 batang pen, sebatang pensel dan 4 batang pembaris juga dengan harga yang sama dengan Ali. Manakala Cheng membeli 2 batang pen, 2 batang pensel dan 1 batang pembaris dengan harga RM 4.10. Cari harga bagi sebatang pen, pensel dan pembaris yang dijual oleh kedai tersebut.

Ali, Belle and Cheng have planned to buy pen, pencil and ruler from a same shop for their school apparatus. Ali bought a pen, 3 pencils and 2 rulers for RM 4. Belle bought 2 pens, a pencil, and 4 rulers with the price as same as Ali. Meanwhile Cheng bought 2 pens, 2 pencils and a ruler for RM 4.10. Find the price for each pen, pencil and ruler that been sold at the shop.

[1.20,0.60,0.50]

3.2 : Persamaan serentak melibatkan satu persamaan linear dan satu persamaan tidak linear.
3.2 simultaneous equation with one linear equation and one non-linear equation

Contoh 1:

Example 1:

Selesaikan persamaan berikut (dalam 2 tempat perpuluhan):
Solve these equations (in 2 decimal point):

$$\begin{aligned} 2x - 3y &= 13 \\ x^2 + y^2 - 2x + 2y &= 3 \end{aligned}$$

Penyelesaian / *solution:*

1. Jadikan persamaan linear mempunyai perkara rumus.
Express the linear equation to form a variable equation.

$$\begin{aligned} 2x - 3y &= 13 \\ x &= \frac{3y+13}{2} \end{aligned}$$

2. Masukkan persamaan 1 kedalam persamaan tidak linear.
Substitute equation 1 into non-linear equation.

$$\left(\frac{3y+13}{2}\right)^2 + y^2 - 2\left(\frac{3y+13}{2}\right) + 2y = 3$$

3. Selesaikan persamaan tersebut sehingga menjadi bentuk am kuadratik.
Solve the equation until it become standard quadratic equation.

$$\begin{aligned} \left(\frac{3y+13}{2}\right)^2 + y^2 - 2\left(\frac{3y+13}{2}\right) + 2y &= 3 \\ \left(\frac{9y^2+78y+169}{4}\right) + y^2 - \frac{6y+26}{2} + 2y &= 3 \\ 9y^2 + 78y + 169 + 4y^2 - 12y - 52 + 8y &= 12 \\ 13y^2 + 74y + 105 &= 0 \end{aligned}$$

4. Gunakan rumus mencari punca kuadratik iaitu $x = \frac{-b \pm \sqrt{b^2 - 4ac}}{2a}$.

Use the formulae $x = \frac{-b \pm \sqrt{b^2 - 4ac}}{2a}$ to find the root of quadratic equation.

$$y = \frac{-74 \pm \sqrt{74^2 - 4(13)(105)}}{2(13)} = -2.69, -3.00$$

5. Gantikan nilai punca kedalam persamaan 1 untuk mendapatkan nilai pembolehubah yang lain satu.
Substitute the root into equation 1 to find the other variable.

$$x = \frac{3(-2.69)+13}{2} = 2.465$$

$$x = \frac{3(-3)+13}{2} = 2.00$$

LATIHAN :
EXERCISE:

- 1 Selesaikan persamaan serentak berikut dan berikan dalam 2 tempat perpuluhan
Solve the simultaneous equations Give your answers correct to two decimal places.
- $$x - 4y = 9 \text{ dan/and } 3y^2 = 7 - \frac{x}{2}.$$
- (Ans: $x = 11.56$, $y = 0.64$ and $x = 3.76$, $y = -1.31$)
- 2 Selesaikan persamaan serentak berikut dalam 4 angka beerti.
Solve the simultaneous equations correct to four significant figures.
- $$3x - 2y = 6 \text{ and } 2x^2 + 4xy - 2 = 0.$$
- (Ans: $x = 1.651$, $y = -0.5235 / -0.5229$ and $x = -0.1513$, $y = -3.227$)
- 3 Selesaikan persamaan serentak berikut.
Solve the simultaneous equations
- $$4x + y = -8 \text{ and } x^2 + x - y = 2.$$
- (Ans: $x = -3$, $y = 4$ and $x = -2$, $y = 0$)
- 4 Selesaikan persamaan serentak berikut.
Solve the simultaneous equations
- $$x + \frac{1}{2}y = 1 \text{ and } y^2 - 10 = 2x.$$
- (Ans: $x = 3$, $y = -4$ and $x = -\frac{1}{2}$, $y = 3$)
- 5 Diberi perbezaan lilitan dua bulatan ialah 4π cm dan jumlah luas keduanya ialah 52π cm². Cari jejari setiap bulatan tersebut.
Given that the different of the circumferences of the two circles is 4π cm and the sum of their areas is 52π cm². Find the radius of each circle.
- (Ans: 4, 6)
- 6 Seutas wayar berbentuk bulatan mempunyai jejari 14 cm dibengkokkan untuk membentuk segiempat dengan panjang $(2y + 20)$ cm dan $(x + 10)$ cm. diberi luas segiempat tersebut ialah 420 cm², cari nilai x dan y.
A piece of wire in shape of a circle with radius 14 cm is bent to form a rectangle with sides $(2y + 20)$ cm long $(x + 10)$ cm wide. Given that the area of rectangle is 420 cm², find the values of x and the value of y.
- (Ans: $x = 4$, $y = 5$ and $x = 20$, $y = -3$)

Bab 4 - Indeks, Surd dan Logaritma / Indices, Surds and Logarithms

4.1 Hukum Indeks / Law of Indices

NOTA RINGKAS / Short Notes

<p>(1) Indeks positif / negatif / sifar / Pecahan <i>Positive / negative / zero / fractional indices</i></p> <ol style="list-style-type: none"> $a^4 = a \times a \times a \times a$ $a^{-m} = \frac{1}{a^m}$ $a^0 = 1$ $a^{\frac{m}{n}} = (\sqrt[n]{a})^m$ 	<p>(2) Hukum Indeks / <i>Law of indices</i></p> <ol style="list-style-type: none"> $a^m \times a^n = a^{m+n}$ $a^m \div a^n = a^{m-n}$ $(a^m)^n = a^{mn}$ $a^m \times b^m = (ab)^m$ $\frac{a^m}{b^m} = \left(\frac{a}{b}\right)^m$ 	<p>(3) Penyelesaian persamaan indeks / <i>Problem solving involving indices.</i></p> <p>Jika $a^x = a^y$, maka $x = y$ If $a^x = a^y$, then $x = y$</p> <p>Jika $a^x = b^x$, maka $a = b$ If $a^x = b^x$, then $a = b$</p>
-------------------------------------------------------------------------------------------------------------------------------------------------------------------------------------------------------------------------------------------------------------------------------------------------------------------------------------------------------	--------------------------------------------------------------------------------------------------------------------------------------------------------------------------------------------------------------------------------------------------------------------------------------------------------------------------------------------------	----------------------------------------------------------------------------------------------------------------------------------------------------------------------------------------------------------------------------------------------------------------------------------------------------------------------------

4.1.1 Mempermudahkan ungkapan algebra yang melibatkan indeks

Simplify the algebraic expressions involving indices

Contoh / Example	Catatan / Remarks
$\begin{aligned} & 3^{3n-2} \div 3^{n-3} \\ &= 3^{3n-2-(n-3)} \\ &= 3^{3n-2-n+3} \\ &= 3^{2n+1} \end{aligned}$	<p>Guna hukum indeks</p> $a^m \div a^n = a^{m-n}$

AKTIVITI 1 / ACTIVITY 1

Permudahkan setiap yang berikut / *Simplify the following algebraic expressions:*

<p>1. $7^{x-1} \times 7^{x-3}$</p> <p style="text-align: right;">7^{2x-4}</p>	<p>2. $2^{4n} \times 2^{4-n}$</p> <p style="text-align: right;">2^{3n+4}</p>	<p>3. $3^{1-2n} \times 3^4 \times 3^{3n+2}$</p> <p style="text-align: right;">3^{n+7}</p>
<p>4. $(3^4)^{2n} \times 3^n$</p> <p style="text-align: right;">3^{9n}</p>	<p>5. $8^{n+1} \div 4^{2n-1}$</p> <p style="text-align: right;">2^{5-n}</p>	<p>6. $3^{3m} \times 9^{m-1} \div 9^{m+3}$</p> <p style="text-align: right;">3^{3m-8}</p>
<p>7. $25^{2p+1} \div 125^{1-2p}$</p> <p style="text-align: right;">5^{10p-1}</p>	<p>8. $25^{3n+3} \div 5^{7n-3} \times 125^{n-1}$</p> <p style="text-align: right;">5^{2n+6}</p>	<p>9. $18^{n+1} \div 10^{1+n} \times 15^{1-2n}$</p> <p style="text-align: right;">$27(5^{-3n})$</p>

10. $\frac{p^{n+2} \times p^{3-2n}}{p^{5+3n}}$	11. $\frac{5^{y+2} \times 25^{y+3}}{125^{y+3}}$	12. $\frac{3^{6-n}}{6^{3+n} \times 2^{9-n}}$
p^{-4n}	$\frac{1}{5}$	$\frac{3^{3-2n}}{2^{12}}$

AKTIVITI 2/ ACTIVITY 2

Permudahkan setiap yang berikut kepada sebutan yang paling ringkas:

Simplify each of the following

1. $3^x + 3^{x+1}$	2. $2^{n+1} - 2^n$
$3^x(4)$	2^n
3. $4^{x+1} - 4^x + 4^{x-1}$	4. $2^{n+2} - 2^n + 12(2^{n-1})$
$4^x(\frac{21}{4})$	$2^n(7)$
5. $2(3^{p+2}) + 3^{p+1} - 3^p$	6. $5^x + 6(5^{x-1}) + 15(5^{x-2})$
$3^p(20)$	$5^x(\frac{14}{5})$

$$7. 3(9^{x+4}) = 27^{x+1}$$

$$8. 5^{3x} \div 25^{x+1} = \frac{1}{125}$$

6

-1

$$9. \sqrt{27^{x+4}} = \frac{1}{3^{x+3}9^x}$$

$$10. 125^{x-1} = \frac{25}{\sqrt{5^{x+3}}}$$

-2

1

Contoh / Example 2 : Selesaikan persamaan / Solve the equation $3^{x+2} = 24 + 3^x$

Langkah-langkah / Steps	Penyelesaian/ Solution
1. Guna hukum indeks $a^m \times a^n = a^{m+n}$ Use the law of indices $a^m \times a^n = a^{m+n}$	$3^{x+2} - 3^x = 24$
2. faktorkan ungkapan sebelah kiri <i>Factorise the expression on the left</i>	$3^x(3^2 - 1) = 24$
3. ringkaskan sebutan dalam kurungan <i>Simplify the term in the bracket</i>	$3^x(8) = 24$
4. Jadikan 3^x sebagai subjek <i>Make 3^x as the subject</i>	$3^x = \frac{24}{8}$
5. samakan sebutan indeks <i>Equate the terms of the index</i>	$3^x = 3^1$
6. cari nilai x <i>Find the value of x</i>	$x = 1$

AKTIVITI 4 / ACTIVITY 4

Selesaikan persamaan berikut / Solve the following indices equations:

1. $5^{2x} - 5^{2x-1} = 100$

$\frac{3}{2}$

2. $2^{x+2} = 20 - 2^x$

2

3. $2^{x+4} - 2^{x+3} = 1$

-3

4. $5^{x+1} + 5^x = 150$

2

5. $3^{x+2} = 24 + 3^x$

1

6. $2(3^{x+2}) + 3^{x+1} = 63$

1

Contoh 2 : Husna mempunyai wang sebanyak RM1 000 000. Dia melaburkan wang itu dalam sebuah institusi pelaburan yang menawarkan pulangan sebanyak 6% setahun. Jumlah pelaburan Husna selepas n tahun dihitung menggunakan persamaan $J = p(1 + k)n$ dengan p sebagai pelaburan awal tahun dan k sebagai kadar pulangan setahun. Cari jumlah pelaburan Husna selepas 20 tahun.

Example 2 : Husna has money of RM1 000 000. She invests the money in an institution investments that offer a return of 6% per annum. The total investment of Husna after n years is calculated using the equation $J = p (1 + k) n$ with p as the investment at the beginning of the year and k as the rate annual return. Find the total investment of Husna after 20 years.

<p>Maklumat Daripada Soalan / Information from the questions:</p> <p>Pelaburan awal, $p =$</p> <ul style="list-style-type: none"> ◆ Kadar pulangan, $k =$ ◆ Rumus pelaburan, ◆ $n =$ ◆ Cari jumlah pelaburan selepas 20 tahun 	<p>Penyelesaian / Solution:</p>
<p>Bentuk Persamaan dalam bentuk Indeks / Equations in index form:</p>	

3) Apabila suatu nombor tidak dapat diringkaskan dengan menghapuskan punca kuasanya (Sama ada Punca kuasa dua atau Punca kuasa tiga dan sebagainya) maka itu adalah surd.
*When a number cannot be simplified by eliminating **punca kuasanya**, then it is a **surds**.*

Contoh: $\sqrt{2}$ (surd 2 peringkat 2) tidak boleh diringkaskan lagi jadi ia adalah **surd**
*Example : $\sqrt{2}$ (surd 2 peringkat 2) cannot be simplified, hence it is a **surds***

Contoh: $\sqrt{4}$ (surd 4 peringkat 2) boleh diringkaskankan (menjadi 2), jadi ia **bukan surd!**
*Example: $\sqrt{4}$ (surd 4 peringkat 2) can be simplified into 2, hence it is not a **surds!***

Lihat contoh-contoh berikut :
Look at the following examples:

Nombor/ Numbers	Nombor Diringkaskan/ Simplified Numbers	Nombor Dalam Perpuluhan/ Decimal numbers	Surd atau Bukan Surd Surds or Not a Surds
$\sqrt{2}$	$\sqrt{2}$	1.4142135...(etc)	Surd
$\sqrt{3}$	$\sqrt{3}$	1.7320508...(etc)	Surd
$\sqrt{4}$	2	2	<i>Bukan surd / Not a surds</i>
$\sqrt[1]{4}$	$\frac{1}{2}$	0.5	<i>Bukan surd / Not a surds</i>
$\sqrt[3]{11}$	$\sqrt[3]{11}$	2.2239800...(etc)	Surd
$\sqrt[3]{27}$	3	3	<i>Bukan surd / Not a surds</i>
$\sqrt[5]{3}$	$\sqrt[5]{3}$	1.2457309...(etc)	Surd

Daripada jadual di atas, **Surd** itu mempunyai **perpuluhan tak terhingga tanpa berulang**, dan ia adalah **Nombor Tak Nisbah**.

From the table above, the Surd has an infinite decimal without repetition, and it is an Irrational Number

Kesimpulannya

- Apabila nombor itu adalah punca kuasa dan tidak nisbah, maka ia adalah surd.
- Tetapi bukan semua punca kuasa adalah surd.

Aktiviti 1

Tukarkan perpuluhan berulang berikut kepada pecahan.

Activity 1

Convert the following repeated decimals to fractions.

(a) 0.676767...	(b) 12.645645645...
-----------------	---------------------

--	--

Aktiviti 2

Tentukan sama ada yang berikut adalah surd atau bukan. Beri alasan anda.

Activity 2

Determine whether the following is surd or not. Give your reasons.

(a) $\sqrt[3]{125}$	(b) $\sqrt[5]{125}$	(c) $\sqrt[4]{\frac{16}{64}}$
---------------------	---------------------	-------------------------------

Latih Diri 4.3 [MS 99]

Hukum-Hukum Surd / Laws of Surd

Hukum 1/Law 1 : $\sqrt{(a \times b)} = \sqrt{a} \times \sqrt{b}$

Contoh 1/ Example 1 :
Ringkaskan / Simplify $\sqrt{18}$:

$18 = 9 \times 2 = 3^2 \times 2$, di mana 9 ialah nombor kuasa dua sempurna terbesar dan faktor bagi 18
/ where 9 is the largest perfect square number and a factor of 18

$$\begin{aligned} \therefore \sqrt{18} &= \sqrt{3^2 \times 2} \\ &= \sqrt{3^2} \times \sqrt{2} \\ &= 3\sqrt{2} \end{aligned}$$

Guna Hukum $\sqrt{(a \times b)} = \sqrt{a} \times \sqrt{b}$

Hukum 2 / Law 2 : $\sqrt{\frac{a}{b}} = \frac{\sqrt{a}}{\sqrt{b}}$

Contoh/ Example :

Mempermudahkan/ Simplify $\sqrt{\frac{12}{121}}$:

Guna Hukum $\sqrt{\frac{a}{b}} = \frac{\sqrt{a}}{\sqrt{b}}$

$$\sqrt{\frac{12}{121}} = \frac{\sqrt{12}}{\sqrt{121}}$$

$$= \frac{\sqrt{2^2 \times 3}}{11}$$

$$= \frac{\sqrt{2^2} \times \sqrt{3}}{11}$$

$$= \frac{2\sqrt{3}}{11}$$

di mana 4 ialah nombor kuasa dua sempurna terbesar dan faktor bagi 12

where 4 is the largest perfect square number and a factor of 12

Guna Hukum $\sqrt{(a \times b)} = \sqrt{a} \times \sqrt{b}$

Aktiviti 3/ Activity 3

Tulis yang berikut sebagai surd tunggal./ Write the following as a single surd.

(a) $\sqrt{2} \times \sqrt{7}$	(b) $\sqrt{3a} \times \sqrt{5a}$
(a) $\frac{\sqrt{24}}{\sqrt{8}}$	(d) $\frac{\sqrt{21a}}{\sqrt{7a}}$

Latih Diri 4.4 [MS101]

Latih Diri 4.5 [MS 102]

Penambahan, Penolakan dan Pendaraban Surd /Addition, Subtraction and Multiplication Surd

Ungkapan yang melibatkan surd boleh dipermudahkan dengan melaksanakan operasi penambahan, penolakan dan pendaraban surd.

Expressions involving surds can be simplified by performing operations addition, subtraction and multiplication of surd.

Aktiviti 4 : Mengenalpasti surd serupa dan surd tak serupa.

Activity 4: Identify similar surds and dissimilar surds.

1. Tentukan sama ada surd yg diberikan berikut serupa atau tak serupa

1. Determine whether the following given surds are similar or dissimilar

Contoh / Example	Surd Yang Serupa / Tak Serupa

		Similar / Dissimilar Surd
1	$\sqrt{5}, 7\sqrt{5}, 10\sqrt{5}, -3\sqrt{5}, 5^{1/2}, 10\cdot\sqrt{5}, 12\cdot 5^{1/2}$	
2	$\sqrt{2}, 9\sqrt{3}, 8\sqrt{5}, \sqrt[3]{6}, \sqrt[4]{17}, 7^{5/6}$	

2. Tentukan sama ada set ungkapan $4\sqrt{12}$, $55\sqrt{18}$ dan $5\sqrt{6}$ adalah surd serupa atau surd tak serupa.

2. Determine whether the set of expressions, $4\sqrt{12}$, $55\sqrt{18}$ and $5\sqrt{6}$ are similar surds or dissimilar surds.

Penyelesaian / Solutions:

Aktiviti 5/ Activity 5

Permudahkan setiap yang berikut dalam bentuk $a\sqrt{b}$.

(a) $4\sqrt{27}$

(b) $7\sqrt{243}$

(c) $5\sqrt{75}$

Penyelesaian/ Solutions

a)	b)	c)
----	----	----

Aktiviti 6/ Activity 6

Permudahkan ungkapan yang berikut./ Simplify the following expressions

(a) $\sqrt{2} \times \sqrt{3} + \sqrt{6}$

(b) $\sqrt{7}(6 - \sqrt{7})$

(c) $\sqrt{18} - \sqrt{8}$

(d) $(6 + 2\sqrt{2})(1 + 3\sqrt{2})$

Penyelesaian / Solutions :

(a)	(b)
-----	-----

Tip Penting

1. Hanya surd yg serupa boleh ditambahkan atau ditolakan.

2. Ringkaskan surd dahulu sebelum tambah atau tolak

Important Tip

1. Only similar surds can be added or subtracted.

2. Simplify the surd first before adding or subtracting

(c)	(d)
-----	-----

Nota Penting / Important Notes

1 $\sqrt{a} \times \sqrt{a} = (\sqrt{a})^2 = a$
2 $\sqrt{a} \times \sqrt{b} = \sqrt{ab}$

3 $\frac{\sqrt{a}}{\sqrt{b}} = \sqrt{\frac{a}{b}}$
4 $m\sqrt{a} \pm n\sqrt{a} = (m \pm n)\sqrt{a}$

Latihan 4.6 [MS103]

Menisbahkan penyebut bagi ungkapan yang melibatkan surd
Rationalising the denominators for expressions involving surds

<p>Hukum 3 / Law 3:</p> $\frac{b}{\sqrt{a}} = \frac{b}{\sqrt{a}} \times \frac{\sqrt{a}}{\sqrt{a}} = \frac{b\sqrt{a}}{a}$	<p>Contoh / Example :</p> <p>Nisbahkan / Rationalise $\frac{5}{\sqrt{7}}$</p> <div style="display: flex; align-items: center;"> $\frac{5}{\sqrt{7}} = \frac{5}{\sqrt{7}} \times \frac{\sqrt{7}}{\sqrt{7}}$ <div style="margin-left: 20px; border: 1px solid black; padding: 5px; width: fit-content;"> <p>Darab penyebut dan pengangka dengan $\sqrt{7}$</p> <p><i>Multiply the numerator and denominator with $\sqrt{7}$</i></p> </div> </div> $= \frac{5\sqrt{7}}{7}$
<p>Hukum 4/ Law 4:</p> $\frac{c}{a+b\sqrt{n}}$ <p>Darab penyebut dan pengangka dengan $a - b\sqrt{n}$</p> <p><i>Multiply the numerator and denominator with $a - b\sqrt{n}$</i></p>	<p>Contoh / Example :</p> <p>Nisbahkan / Rationalise $\frac{3}{2+\sqrt{2}}$.</p> <div style="display: flex; align-items: center;"> $\frac{3}{2+\sqrt{2}} = \frac{3}{2+\sqrt{2}} \times \frac{2-\sqrt{2}}{2-\sqrt{2}}$ <div style="margin-left: 20px; border: 1px solid black; padding: 5px; width: fit-content;"> <p>Darab penyebut dan pengangka dengan surd konjugat $\sqrt{2 - \sqrt{2}}$</p> <p><i>Multiply the numerator and denominator with the conjugate surd $\sqrt{2 - \sqrt{2}}$</i></p> </div> </div> $= \frac{6-3\sqrt{2}}{4-2}$ $= \frac{6-3\sqrt{2}}{2}$

<p>Hukum 5 / Law 5 :</p> $\frac{c}{a-b\sqrt{n}}$ <p>Darab penyebut dan penangka dengan $a + b\sqrt{n}$</p> <p><i>Multiply the numerator and denominator with $a + b\sqrt{n}$</i></p>	<p>Contoh/ Example :</p> $\frac{3}{2-\sqrt{2}}$ <p>Nisbahkan / Rationalise</p> $\frac{3}{2-\sqrt{2}} = \frac{3}{2-\sqrt{2}} \times \frac{2+\sqrt{2}}{2+\sqrt{2}}$ $= \frac{6+3\sqrt{2}}{4-2}$ $= \frac{6+3\sqrt{2}}{2}$
------------------------------------------------------------------------------------------------------------------------------------------------------------------------------------------------------------	-------------------------------------------------------------------------------------------------------------------------------------------------------------------------------------------------------------------------

Darab penyebut dan penangka dengan $\sqrt{2 + \sqrt{2}}$

Multiply the numerator and denominator with $\sqrt{2 + \sqrt{2}}$

Aktiviti 7/ Activity 7 : Nisbahkan penyebut dan permudahkan setiap yang berikut.
Rationalise the denominator and simplify each of the following.

- (a) $\frac{1}{5\sqrt{3}}$ (b) $\frac{1}{7\sqrt{2} + 5\sqrt{3}}$ (c) $\frac{1}{2\sqrt{3} - 5\sqrt{7}}$

Penyelesaian / Solution :

(a)	(b)	(c)
-----	-----	-----

Aktiviti 8/ Activity 8 :

Nisbahkan penyebut dan permudahkan $\frac{1 + \sqrt{3}}{1 - \sqrt{3}}$.

Rationalise the denominator and simplify

Penyelesaian/Solution :

Aktiviti 9 / Activity 9 :

Tuliskan $\frac{5 + \sqrt{7}}{1 + \sqrt{3}} + \frac{4 - \sqrt{7}}{1 - \sqrt{3}}$ sebagai pecahan tunggal.

Write as $\frac{5 + \sqrt{7}}{1 + \sqrt{3}} + \frac{4 - \sqrt{7}}{1 - \sqrt{3}}$ a single fraction

Penyelesaian / Solution :

Menyelesaikan masalah yang melibatkan surd.
Solving problems involving surds.

Aktiviti 10 / Activity 10

Rajah di sebelah menunjukkan sebuah rumah berbentuk piramid. Bahagian hadapan rumah itu yang berbentuk segi tiga mempunyai keluasan $(20\sqrt{3} - 4) \text{ m}^2$ dengan panjang tapaknya ialah $(4 + 4\sqrt{3}) \text{ m}$. Cari tinggi bahagian hadapan rumah yang berbentuk segi tiga itu dalam bentuk $(a + b\sqrt{3})$, dengan a dan b ialah nombor nisbah.



The diagram on the right shows a pyramid-shaped house. The triangle shape at the front of the house has an area of $(20\sqrt{3} - 4) \text{ m}^2$ and the length of its base is $(4 + 4\sqrt{3}) \text{ m}$. Determine the height of the triangle at the front of the house in the form of $(a + b\sqrt{3})$, where a and b are rational numbers.

Penyelesaian/ Solution :

Aktiviti 11 : Menyelesaikan persamaan surd./ *Solving problems involving surds.*

Contoh / Example

Selesaikan $x - 4\sqrt{x} + 3 = 0$.

Penyelesaian :

4.3 HUKUM LOGARITMA

4.3 Laws of Logarithms

4.3.1 Menghubungkan persamaan dalam bentuk indeks dengan bentuk logaritma dan menentukan nilai logaritma sesuatu nombor.

Relate equations in the form of indices and logarithms, and hence determine the logarithm of a number.

Aktiviti 1

Logaritma
Logarithms

Jika $\log_a N = x$, maka $N = a^x$
[dengan $a > 0$ dan $a \neq 1$]

If $\log_a N = x$, then $N = a^x$
[with $a > 0$ dan $a \neq 1$]

* *Perlu dihafal kerana tidak diberi semasa peperiksaan*
-Need to memorise because it was not given during the exam

Tukarkan persamaan dalam bentuk **indeks** yang diberikan di bawah kepada bentuk **logaritma**.
Convert the equation in the form of the **index** given below to the **logarithmic** form.

a) $a^0 = 1$

b) $a^1 = a$

Maka, untuk sebarang nombor nyata, $a > 0$ dan $a \neq 1$,
So, for any real number, $a > 0$ and $a \neq 1$,

Aktiviti 2

Sekarang cuba guna kalkulator, cari nilai-nilai berikut
Now try using a calculator to find the following values

a) $\log_7 0 =$

b) $\log_{10} (-10) =$

c) $\log_1 13 =$

Pemerhatian :

Observation :

1. N _____ 0
2. Asas, a _____ 0 dan a _____ 1
Base a _____ 0 and a _____ 1

Kesimpulan :

Conclusion :

$\log_a N$ tertakrif jika _____
 $\log_a N$ is defined if _____

Latihan 4.3.1

Exercise 4.3.1

1. Tukarkan persamaan dalam bentuk **indeks** kepada bentuk **logaritma**.

*Convert the equation in **index** form to the **logarithmic** form.*

Contoh :

Example :

(a) $10^2 = 100$	(b) $2^3 = 8$	(c) $p^q = r$
------------------	---------------	---------------

Latihan

Exercise

(1) $10^4 = 10000$	(2) $a^3 = b$	(3) $81 = 3^4$
(4) $2^x = y$	(5) $V = 10^x$	(6) $\frac{1}{18} = 3^{-4}$
(7) $2^5 = 32$	(8) $10x = y^3$	(9) $1 = 10^0$

2. Tukarkan persamaan dalam bentuk **logaritma** kepada bentuk **indeks**.

*Convert the equation in **logarithmic** form to **index** form*

Contoh :

Example :

(a) $\log_2 8 = 3$	(b) $\log_3 81 = 4$	(c) $\log_4 16 = 2 \log_3 \frac{1}{27} = -3$
--------------------	---------------------	----------------------------------------------

Latihan:

Exercise

(1) $\log_p m = k$	(2) $\log_3 x = y$	(3) $\log_a y = 2$
(4) $\log_3 (xy) = 2$	(5) $\log_{10} 100y = p$	(6) $\log_3 (xy) = 5$

3. Cari nilai bagi setiap yang berikut dengan menggunakan kalkulator saintifik.
Find the value of each of the following using a scientific calculator.

(a) $\log_{10} 26$	(b) $\log_{10} 1$	(c) $\log_{10} 10$
(d) $\log_{10} \frac{1}{45}$	(e) $\log_{10} 9^3$	(f) $\log_{10} 0.156$

4. Cari nilai bagi setiap yang berikut **TANPA** menggunakan kalkulator saintifik.
*Find the value of each of the following **WITHOUT** using a scientific calculator.*

(a) $\log_2 8 = x$	(b) $\log_9 81 =$	(c) $\log_4 \frac{1}{64} =$
(d) $\log_9 3 =$	(e) $\log_8 4 =$	(f) $\log_4 0.25 =$
(g) $\log_{49} 7$	(h) $\log_5 125$	(i) $\log_2 16$

5. Cari nilai x bagi setiap persamaan berikut.
Find the value of each of the following equations

(a) $\log_3 x = 4$	(b) $\log_4 y = 4$	(c) $\log_x 8 = \frac{1}{2}$
--------------------	--------------------	------------------------------

(d) $\log_x 27 = 3$	(e) $\log_x \frac{1}{625} = -4$	(f) $\log_m 216 = 3$
---------------------	---------------------------------	----------------------

6. Cari nilai bagi setiap yang berikut.
Find the value of each of the following.

(a) $\text{anti log } 3$	(b) $\text{anti log } 0.2078$	(c) $\text{anti log } 2.395$
(d) $\text{anti log } (-0.2998)$	(e) $\text{anti log } (-1.17)$	(f) $\text{anti log } \left(-\frac{1}{24}\right)$

Latihan 4.9 [MS113]
 Exercise 4.9 (PG 113)

4.3.2 Membuktikan hukum logaritma

4.3.2 Prove laws of logarithms.

Aktiviti 1

Buktikan hokum-hukum Loagaritma berikut
Prove the following laws of logarithms

1. Hukum Hasil Darab Product law	2. Hukum Hasil Bahagi Divison Law	3. Hukum Kuasa Power Law
$\log_a xy = \log_a x + \log_a y$	$\log_a \frac{x}{y} = \log_a x - \log_a y$	$\log_a x^n = n \log_a x$ untuk sebarang nombor nyata n for any real number n

Andaikan $\log_a x = p$ dan $\log_a y = q$

Maka $x = a^p$ dan $y = a^q$

Jika $\log_a N = x$, maka $N = a^x$

If $\log_a x = p$ and $\log_a y = q$

Then $x = a^p$ and $y = a^q$

If $\log_a N = x$, then $N = a^x$

$x \cdot y =$	$\frac{x}{y} =$	$\log_a x^n = \log_a (x \cdot x \cdot x \dots \dots \dots x)$ = =
---------------	-----------------	-------------------------------------------------------------------------

Latihan 4.3.2 Aplikasi Hukum Logaritma : [$\log_p MN = \log_p M + \log_p N$ dan $\log_p \frac{M}{N} = \log_p M - \log_p N$]

Exercise 4.3.2 Applications Law of Logaritms [$\log_p MN = \log_p M + \log_p N$ and $\log_p \frac{M}{N} = \log_p M - \log_p N$]

1.	$\log_a 3pr = \log_a 3 + \log_a p + \log_a r$	(a) $\log_a 2mn =$
	(b) $\log_a 3aq =$	(c) $\log_{10} 10yz =$
	(d) $\log_{10} 1000xy =$	(e) $\log_2 4mn =$
2.	$\log_a \frac{p}{q} = \log_a p - \log_a q$	(a) $\log_a \frac{p}{2r} = \log_a p - \log_a 2r$ $= \log_a p - (\log_a 2 + \log_a r)$ $=$
	(b) $\log_2 \frac{4}{m} =$	(c) $\log_{10} \left(\frac{10}{kx} \right) =$
	(d) $\log_{10} \left(\frac{xy}{100} \right) =$	(e) $\log_a \frac{3a}{m} =$

Latihan 4.3.2 Aplikasi Hukum logaritma : [$\log_a x^n = n \log_a x$]

Exercise 4.3.2 Applications Law of Logaritms

1.	$\log_{10} 1000 =$	6.	$\log_p p^8 =$	11.	$\log_a a^2 =$
2.	$\log_2 32 =$	7.	$\log_m m^{-1} =$	12.	$\log_m \frac{1}{m^2} =$

3.	$\log_{10} 0.01 =$	8.	$\log_a a^{\frac{1}{3}} =$	13	$\log_p p^{-5} =$
4.	$\log_4 64 =$	9.	$\log_a \frac{1}{a^4} =$	14	$\log_b b^k =$
5.	$\log_p \sqrt{p} =$	10.	$\log_p (p \times p^2) =$	15	$\log_p p(\sqrt{p}) =$

Aktiviti 2
Activity 2

Cari nilai bagi setiap yang berikut **TANPA** menggunakan kalkulator.
Find the value of each of the following **WITHOUT** using a scientific calculator.

(a) $\log_5 750 - \log_5 6$	(b) $\log_3 8 + 2 \log_3 6 - \log_3 \frac{96}{9}$

Latihan Aplikasi Hukum-hukum Asas Logaritma
Exercise of Basic Law of Logarithms

1. Cari nilai bagi setiap yang berikut **TANPA** menggunakan kalkulator saintifik.
1. Find the value of each of the following **WITHOUT** using a scientific calculator.

(a) $2\log_2 5 - \log_2 75 + \log_2 24$	(b) $\log_3 \frac{1}{15} + \log_3 5$	(c) $3\log_4 6 - \log_4 108$

(d) $\log_5 100 + \log_5 2 - \log_5 8$	(e) $\log_6 18 - \log_6 2 - 2\log_6 3$	(f) $1 + \log_3 108 - \log_3 12$
----------------------------------------	----------------------------------------	----------------------------------

Latihan 4.10 [MS 115]

Exercise 4.10 [PG 115]

Aktiviti 3

Memperudahkan ungkapan algebra menggunakan hukum logaritma

Simplify algebraic expressions using the laws of logarithms.

Ungkapkan setiap yang berikut sebagai satu logaritma tunggal. <i>Express each of the following as a single logarithm</i>		
(a) $\log_a x + 3 \log_a y$	(b) $2 \log_a x - \frac{1}{2} \log_a y$	(c) $2 \log_3 x + \log_3 y - 1$

Latihan Aktiviti 3

1. Pemudahkan setiap ungkapan logaritma berikut kepada bentuk yang teringkas.

Simplify each of logarithm expression to the simplest form.

(a) $\log_a y + \log_a y^2 - \log_a x^2 y$	(b) $\log_a x - 3\log_a x + \log_a (y+1)$	(c) $\log_a (m^2 - n^2) - \log_a (m+n)$
--------------------------------------------	-------------------------------------------	-----------------------------------------

3. Jika $p = \log_b 2$, $q = \log_b 3$ dan $r = \log_b 5$, tuliskan yang berikut dalam sebutan p , q dan/atau r .
 If $p = \log_b 2$, $q = \log_b 3$ dan $r = \log_b 5$, write the following in terms of p , q and / or r .

(a) $\log_b 6$	(b) $\log_b 45$
(c) $\log_b 0.2222\dots$	(d) $\log_b = \left(\frac{5\sqrt{3}}{2}\right)$

Latih Diri 4.11 [MS116]
 Self Practice 4.11 [PG 116]

Aktiviti 4 Penukaran Asas Logaritma
Activity 4 Conversion of basic of logarithm

Jika a , b dan c ialah nombor positif, $a \neq 1$ dan $c \neq 1$,
 If a , b and c are positive numbers, $a \neq 1$ and $c \neq 1$,

$$\log_a b = \frac{\log_c b}{\log_c a}$$

Atau
 and

$$\log_a b = \frac{1}{\log_b a}$$

Membuktikan hubungan $\log_a b = \frac{\log_c b}{\log_c a}$ dan menentukan logaritma suatu nombor

Proving the relationship of $\log_a b = \frac{\log_c b}{\log_c a}$ and determining the logarithm of a number

Andaikan $\log_a b = x$, maka, $a^x = b$. If $\log_a b = x$, then, $a^x = b$.	Secara khususnya: Specifically : If $b = c$,
------------------------------------------------------------------------------------------	---------------------------------------------------------

******* Dengan menggunakan hukum penukaran asas, sebarang asas logaritma boleh ditulis dan dinilai menggunakan asas 10 atau asas e.**

Logaritma asas e dikenali sebagai logaritma jati dan ditulis sebagai \log_e atau \ln . Asas e sering digunakan dalam bidang matematik, sains dan teknologi.

By using the law of base change, any logarithmic can be witten or evaluated with base 10 or base e. logarithm with base e are known as natural logarithms and are written as \log_e or \ln . Base e is often used in Mathematics, Science and technology.

Latihan Aktiviti 4

Exercise Activity 4

1. Cari nilai yang berikut dengan menukarkan asasnya kepada 10. <i>Determine the following values by changing their base to 10</i>	
(a) $\log_{30} 4$	(b) $\log_2 0.45$
2. Tukarkan setiap yang berikut kepada logaritma jati dan nilaikan. <i>Convert each of the following to natural logarithms and evaluate them</i>	
(a) $\log_6 254$	(b) $\log_{30} 4$

3. Diberi $\log_5 x = p$, ungkapkan setiap yang berikut dalam sebutan p .
 Given $\log_5 x = p$, express each of the following in term of p .

(a) $\log_{25} x$

(b) $\log_x 25x^3$

Latih Diri 4.12 [MS118]

Self practice 4.12 [MS118]

Aktiviti 5 Menyelesaikan masalah yang melibatkan hukum logaritma

Activity 5 Solve problems involving the laws of logarithms.

5.1 Masalah yang melibatkan indeks, misalnya $3^x = 70$ yang tidak boleh diungkapkan dalam bentuk $a^x = a^y$ atau $a^x = b^x$ boleh diselesaikan dengan menggunakan logaritma.

Problem involving indices, such as $3^x = 70$ cannot be expressed in the form of $a^x = a^y$ or $a^x = b^x$ can be solved by using logarithms.

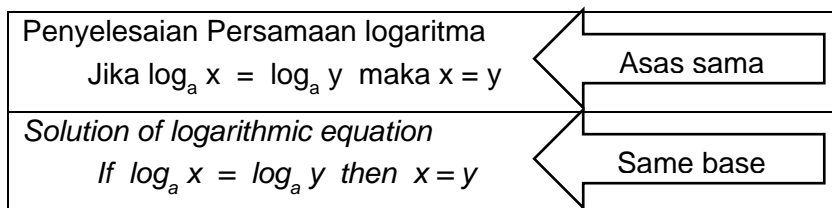

Contoh Example	Steps
Selesaikan persamaan $3^x = 5$ Solve $3^x = 5$ Penyelesaian : Solution $\log_{10} 3^x = \log_{10} 5$ $x \log_{10} 3 = \log_{10} 5$ $x = \frac{\log_{10} 5}{\log_{10} 3}$ $= 1.465$	Logkan kedua-dua belah persamaan kepada asas sepuluh Log both side of equation to basic ten Gunakan hukum logaritma Use logarithmic law $\log_a x^m = m \log_a x$

1. Selesaikan persamaan berikut :
 Solve the following equations :

1. $3^x = 7$	2. $5^x = 27$	3. $5^x = 0.8$
1.77	2.05	0.139

4. $3^{x+1} = 18$	5. $5^{x+2} \times 5^{2x-1} = 100$	6. $2 \times 3^x = 5^{x+1}$
7. $(3^x)(4^{x+1}) = 6$	8. $2^{x+1} - 5^{x+2} = 0$	
1.63	0.621	8.83
0.163	-2.756	

5.2 Masalah yang melibatkan persamaan logaritma jati

Solve the following natural logarithmic equations

(a) $\ln(4x - 2) = 5$

(b) $10e^{2x} = 35$

5.3 Masalah yang melibatkan penyelesaian masalah (soalan panjang)

Problem involving problem solving (long questions)

Suhu sebongkah besi meningkat daripada 30°C kepada $T^\circ\text{C}$ apabila dipanaskan selama x saat.

Diberi $T = 30(1.2)^x$, cari

(a) suhu bongkah besi itu apabila dipanaskan selama 10.4 saat,

(b) masa, x , dalam saat, yang diambil untuk meningkatkan suhu bongkah besi tersebut daripada 30°C kepada $1\ 500^\circ\text{C}$.

The temperature of a block of steel rises from 30°C to $T^\circ\text{C}$ when it was heated for x seconds. Given

$T = 30(1.2)^x$, determine

(a) The temperature of the steel when it is heated for 10.4 seconds,

(b) The time, x in seconds, taken to increase the temperature of the block of steel from 30°C to $1\ 500^\circ\text{C}$

L1 : Kenalpasti kehendak soalan

Identify the requirements of the questions

- ❖ Rumus yang diberi –
- ❖ *Formula given*

- ❖ Peningkatan suhu daripada –
Increase in temperature from

- ❖ Soalan :
Question :
(a) cari T apabila masa , _____ = _____
find T when masa , _____ = _____

- (b) cari x apabila suhu meningkat daripada _____
kpd _____.
*find x when temperature rises from _____
to _____.*

L2

- ◆ Gantikan nilai x ke dalam rumus untuk mencari nilai T .
Substitute the value of x into the formula to find value of T

- ◆ Gantikan nilai T ke dalam rumus untuk mencari nilai x .
Substitute the value of T into the formula to find value of x

L3

L4

Latih Diri 4.13 [MS120]
Self Practice 4.13 [PG 120]

Latihan Intensif 4.3 [MS121]
Intensive practice 4.3 [PG121]

<p>2. Guna hukum logaritma Use law of logarithm</p> $\log_a \frac{m}{n} = \log_a m - \log_a n$	$\text{Log}_{10} \frac{x-5}{x-1} = 2$
<p>3. guna definisi logaritma untuk hapuskan logaritma Use definition of logarithm to eliminate logarithm</p> <p>If $N = a^x$, then $\log_a N = x$</p>	$\frac{x-5}{x-1} = 10^2$
<p>4. selesaikan persamaan untuk cari nilai x Solve the equation to find value of x</p>	$\begin{aligned} x-5 &= 100(x-1) \\ x-5 &= 100x-100 \\ 99x &= 95 \\ x &= \frac{95}{99} \end{aligned}$

Latihan 5.3/5.4. Selesaikan persamaan berikut:
Exercise 5.3/5.4 Solve the following equations :

<p>1. $\log_4 x = \log_4 3$</p> <p style="text-align: right;">3</p>	<p>2. $\log_x 8 - \log_x 2 = 2$</p> <p style="text-align: right;">2</p>
<p>3. $\log_x 25 - \log_x 5 = \frac{1}{2}$</p> <p style="text-align: right;">25</p>	<p>4. $\log_2 (x+5) = \log_2 (x-2) + 3$</p> <p style="text-align: right;">3</p>

$$5. \log_5 (4x - 7) = \log_5 (x - 2) + 1$$

3

$$6. \log_2 (2x - 1) + \log_2 4 = 5$$

$\frac{9}{2}$

$$7. \log_2 6 + 2 \log_2 p = 3$$

$\frac{2}{\sqrt{3}}$

$$8. \log_2 4x = 2 \log_2 6$$

9

$$9. \log_4 (x - 3) = \frac{1}{5} \log_4 32$$

5

$$10. \log_2 (x - 2) + 3 \log_2 8 = 10$$

4

Contoh: Selesaikan persamaan $\log_2 x = \log_4 (3x+4)$

Example: Solve the equation $\log_2 x = \log_4 (3x+4)$

Langkah-langkah <i>Steps</i>	Penyelesaian <i>Solution</i>
1. tukar asas logaritma <i>Change the base of logarithm</i>	$\log_2 x = \frac{\log_2(3x+4)}{\log_2 4}$
2. Guna hukum logaritma <i>Use law of logarithm</i> $\log_a x^m = m \log_a x$	$\log_2 x = \frac{\log_2(3x+4)}{2\log_2 2}$ $\log_2 x = \frac{\log_2(3x+4)}{2}$
3. hapuskan pecahan dan guna hukum logaritma $\log_a x^m = m \log_a x$ <i>Eliminate fraction and use law of logarithm $\log_a x^m = m \log_a x$</i>	$2\log_2 x = \log_2(3x+4)$ $\log_2 x^2 = \log_2(3x+4)$
4. Guna: <i>Use :</i> Jika $\log_a x = \log_a y$ maka $x = y$ <i>If $\log_a x = \log_a y$ then $x = y$</i>	$x^2 = 3x + 4$
5. Selesaikan persamaan kuadratik <i>Solve the quadratic equation</i>	$x^2 - 3x - 4 = 0$ $(x - 3)(x - 1) = 0$ $x = 3, 1$

Aktiviti 4

Activity 4

Selesaikan persamaan berikut:

Solve the following equations

1. $\log_{27} x = \log_3 2$	2. $\log_9 2x + \log_3 2x = \frac{3}{2}$
8	$\frac{3}{2}$

3. $\log_3 x = \log_9 (5x + 6)$

4. $\log_4 (x - 2) + 3\log_2 8 = 10$

6, -1

6

AKTIVITI 5

Activity 5

1. Diberi bahawa $\log_4 5 = p$, ungkapkan setiap yang berikut dalam sebutan p :
Given that $\log_4 5 = p$, express each of the following in terms of p :

(a) $\log_5 16$

(b) $\log_5 4$

(c) $\log_{64} 50$

(d) $\log_{25} 2.5$

(a) $\frac{2}{p}$ (b) $\frac{1}{p}$ (c) $\frac{4p+1}{6}$ (d) $\frac{2p-1}{4p}$

2. Diberi bahawa $\log_3 h = x$ dan $\log_3 k = y$, ungkapkan $\log_{27} \left(\frac{9k}{h} \right)$ dalam sebutan x dan y

Given that $\log_3 h = x$ and $\log_3 k = y$ express $\log_{27} \left(\frac{9k}{h} \right)$ in terms of x and y .

$$\frac{2 + y - x}{3}$$

3. Diberi bahawa $\log_{81} p - \log_3 q = 0$, ungkapkan p dalam sebutan q .
Given that $\log_{81} p - \log_3 q = 0$, express p in terms of q .

$$p = q^4$$

4.4 Aplikasi Indeks , Surd dan Logaritma

4.4 Applications of Indices , Surds and Logarithms

4.4.1 Menyelesaikan masalah yang melibatkan indeks, surd dan logaritma.

Solving problems involving indices, surds and logarithms.

Contoh:

Ahli epidemiologi mendapati bahawa penularan virus Covid-19 di kalangan manusia tersebar seluas $C(n) = 1000 \times 5^{0.2n}$ ekar, dengan n ialah bilangan minggu selepas pemerhatian awal dibuat.

- Cari luas asal kawasan penularan virus Covid-19 .
- Cari luas kawasan penularan virus Covid-19 setelah
 - 5 minggu
 - 10 minggu.
- Berapakah masa yang diambil untuk virus Covid-19 menular ke kawasan seluas 50000 ekar?

Epidemiologists found that the transmission of Covid-19 virus among humans spread over an acre, with n being the number of weeks after the initial observation was made.

- Find the original area of Covid-19 virus infection.
- Find the area of Covid-19 virus infection after
 - 5 weeks
 - 10 weeks.
- How long does it take for the Covid-19 virus to spread to an area of 50000 acres?

Penyelesaian / Solution :

a) $C(n) = 1000 \times 5^{0.2n}$ $C(0) = 1000 \times 5^{0.2(0)}$ $= 1000 \times 5^{0.2(0)}$ $= 1000 \times 1$ $= 1000$ ekar	b) (i) $C(n) = 1000 \times 5^{0.2n}$ $C(4) = 1000 \times 5^{0.2(5)}$ $= 1000 \times 5^1$ $= 5000$ ekar (ii) $C(n) = 1000 \times 5^{0.2n}$ $C(10) = 1000 \times 5^{0.2(10)}$ $= 1000 \times 5^2$ $= 25000$ ekar	c) $C(n) = 1000 \times 5^{0.2n}$ $50000 = 1000 \times 5^{0.2n}$ $50 = 5^{0.2n}$ $\log 50 = \log 5^{0.2n}$ $\log 50 = 0.2n \log 5$ $\frac{\log 50}{\log 5} = 0.2n$ $0.2n = 2.4307$ $n = 12.15$ minggu
-----------------------------------------------------------------------------------------------------------------------------------------	--------------------------------------------------------------------------------------------------------------------------------------------------------------------------------------------------------------------------------------------	------------------------------------------------------------------------------------------------------------------------------------------------------------------------------------------------------------------------------

Jawab semua soalan yang berikut.
Answer all the following questions.

- 1) En. Ilham menyimpan emas sebanyak 100 gram dalam sebuah bank dan nilai 1 gram emas pada ketika itu ialah RM 250. Nilai emas itu meningkat mengikut persamaan $E = 250(1.5)^t$ selepas t tahun. Hitung

En. Ilham kept 100 grams of gold in a bank and the value of 1 gram of gold at that time was RM 250. The value of the gold increased according to the equation after t years. Calculate

- Jumlah nilai emas yang dimiliki oleh En. Ilham dalam Ringgit Malaysia (RM) selepas 5 tahun.
The total value of gold owned by En. Ilham in Ringgit Malaysia (RM) after 5 years.
- Masa , t , dalam tahun jumlah nilai emas meningkat daripada RM 25000 kepada RM50000.
Time, t , in the year the total value of gold increases from RM 25000 to RM50000.

Jawapan / Answer :

[a) RM 189843.75 b) 1.70 tahun].

2) Seorang ahli biologi mengkaji keadaan yang sesuai bagi sejenis bakteria yang membiak. Pada mulanya , dia menyimpan 200 bakteria dalam satu piring dan diketahui bahawa kadar pembiakan , B mengikut rumus $B = B_0 e^{kt}$ dengan keadaan B_0 ialah bilangan asal bakteria, k ialah pemalar yang membiak dan t adalah masa dalam jam. Cari

A biologist is studying the growth of a kind of bacteria in a certain environment. At the beginning , he puts 100 bacteria in a dish and it is known that the growth constant and t is the time in hours. Find

a) Nilai k jika terdapat 650 bakteria selepas 7 jam.
The value of k if there are 450 bacteria after 6 hours.

b) Masa minimum supaya bilangan bakteria akan mencapai 10 kali lebih daripada bilangan asalnya.
The minimum time for the number of bacteria to be 10 times of the initial amount.

[$k = 0.1683$ b) 17.80 jam]

Jawapan / Answer :

3) Rajah menunjukkan sekeping kadbod dalam bentuk segitiga bersudut tegak. Cari luas kadbod itu dalam bentuk $k\sqrt{3}$ dengan keadaan k adalah pemalar.

The diagram shows a piece of cardboard in the shape of right- angled triangle. Find the area of the cardboard in the form $k\sqrt{3}$ where k is a constant.

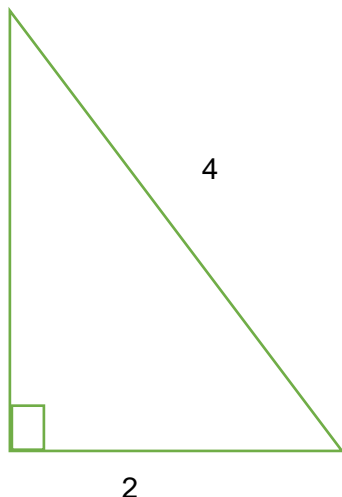

[$2\sqrt{3}$]

Jawapan / Answer :

5.1 : JANJANG ARITMETIK / ARITHMETIC PROGRESSIONS

Janjang Aritmetik / Arithmetic Progressions	
$a, a + d, a + 2d, a + 3d, a + 4d, \dots$ $T_1, T_2, T_3, T_4, T_5, \dots$	
Sebutan ke-n / <i>The nth term</i> $T_n = a + (n - 1)d$ $T_n = S_n - S_{n-1}$	Hasil tambah n sebutan pertama / <i>Sum of the first n terms</i> $S_n = \frac{n}{2}[2a + (n - 1)d]$ $S_n = \frac{n}{2}[a + T_n]$
$a =$ Sebutan pertama / <i>First term</i> $d =$ Beza sepunya / <i>Common difference = $T_n - T_{n-1}$</i>	
<u>ISI KANDUNGAN / CONTENTS</u>	
<p>Hasil Pembelajaran / <i>Learning Outcomes</i> :</p> <p>5.1.1 Mengenal pasti janjang aritmetik. <i>Identifying arithmetic progressions.</i></p> <p>5.1.2 Menerbitkan rumus sebutan ke-n, T_n bagi janjang aritmetik. <i>Deriving the formula of the nth term, T_n of arithmetic progression.</i></p> <p>5.1.3 Menentukan dengan menggunakan rumus : <i>Determining using formula:</i></p> <p>a) sebutan tertentu dalam sesuatu janjang aritmetik. <i>the specific term in an arithmetic progression.</i></p> <p>b) bilangan sebutan dalam suatu janjang aritmetik. <i>the number of terms of an arithmetic progression</i></p>	

5.1.1 Mengenal pasti janjang aritmetik / Identifying arithmetic progressions

NOTA / NOTE :

1. Jujukan / Sequence

Jujukan adalah satu set unsur (biasanya nombor) yang teratur.
Sequence is a set of elements (normally numbers) that is well arranged.

Contoh / *Example* :

- i). 8, 16, 24, 32, ialah jujukan yang mengikut corak tertentu dan terhingga.
8, 16, 24, 32, is a finite sequence that follows a specific pattern.
- ii). 3, -3, 3, -3, ialah jujukan tak terhingga.
3, -3, 3, -3, is an infinite sequence.

Setiap nombor dalam jujukan dikenali sebagai sebutan, dengan sebutan pertama ditulis sebagai T_1 , sebutan kedua T_2 dan seterusnya sehingga sebutan T_n , iaitu sebutan ke-n.

Every number in a sequence is known as terms, such that the first term is written as T_1 , second term T_2 and so on until T_n , which is the n^{th} term.

2. Beza Sepunya JA (simbol “ d ”) / Common Difference AP (symbol “ d ”)

Dalam sesuatu jujukan, untuk jujukan tertentu, istilah yang digunakan adalah sebutan pertama, beza sepunya antara dua sebutan dan sebutan ke- n .

In a progression, for a certain sequence, the terms used are the first term, common difference between two terms and the n^{th} term.

Andaikan, Jika $a_1, a_2, a_3, \dots, a_n$ ialah suatu JA, maka Beza sepunya "d" dapat diperoleh melalui :

<p>Atau / or</p> $d = T_2 - T_1 = T_3 - T_2 = \dots = T_n - T_{n-1}$

Assume that, if $a_1, a_2, a_3, \dots, a_n$ is an AP, then common difference “d” can be obtained through:

<p>Peringatan / Reminder</p> $d \neq T_1 - T_2 \neq T_2 - T_3 \neq \dots \neq T_{n-1} - T_n$

(A) Tentukan sama ada jujukan nombor berikut membentuk suatu jujukan aritmetik atau tidak. Jika jujukan aritmetik, tentukan beza sepunya jujukan itu.

Determine whether the following sequence numbers form an arithmetic progression or not. If it is an arithmetic progression, determine the common difference of the arithmetic progression.

<p>(a) $-4, -10, -16, -22, \dots$</p>	<p>(b) $\frac{1}{16}, \frac{1}{14}, \frac{1}{12}, \frac{1}{10}, \dots$</p>
<p>(c) $34, 46, 58, 70, \dots$</p>	<p>(d) $0.01, 0.09, 0.17, 0.25, \dots$</p>

(e) $3x + 4, 4x + 2, 5x, 6x - 2, \dots$	(f) $2x + 1, 4x, 6x - 2, 8x - 5, \dots$
-----------------------------------------	-----------------------------------------

(B) Penyelesaian Masalah / *Problem Solving*

1. Sebuah auditorium mempunyai 15 buah kerusi pada baris pertama, 19 buah kerusi pada baris kedua, 23 buah kerusi pada baris ketiga dan seterusnya. Tentukan sama ada susunan kerusi pada setiap baris mengikut jangjang aritmetik atau bukan. Beri justifi kasi anda.

An auditorium has 15 chairs in the first row. 19 chairs in the second row, 23 chairs in the third row and so on. Determine whether the arrangement of chairs in each row follows an arithmetic progression. Give your justification.

Penyelesaian :

Latih Diri 5.1 [Buku teks muka surat 129-130]
Self Exercise 5.1 [Textbook page 129-130]

5.1.2 Menerbitkan rumus sebutan ke-n, T_n bagi jangjang aritmetik, JA.

Deriving the formula for the n^{th} term of arithmetic progression, AP.

NOTA / NOTE :

JA juga boleh ditulis dalam bentuk beza sepunya, seperti berikut;
 $a, a + d, a + 2d, a + 3d, a + 4d, \dots, a + (n - 1) d$, di mana a adalah sebutan pertama.

AP can also be written in the term of common difference as below :
 $a, a + d, a + 2d, a + 3d, a + 4d, \dots, a + (n - 1) d$, where a is the first term.

Lengkapkan jadual di bawah.
 Complete the following table.

Kedudukan Sebutan <i>Position of Term</i>	Pewakilan Sebutan <i>Term</i>	Nilai sebutan <i>Value of term</i>
1	T_1	$a = a + (1-1) + d$
2	T_2	$a + d = a + (2-1) + d$
3	T_3	$a + 2d = a + (3-1) + d$
4	T_4	$a + 3d = a + (4-1) + d$
.	.	.
.	.	.
.	.	.
.	.	.
n	T_n	$a + (n-1)d$

Kesimpulan / Conclusion :

Sebutan ke- n bagi suatu jangjang aritmetik boleh ditulis sebagai:

The n^{th} term of an arithmetic progression can be written as :

$$T_n = a + (n - 1)d$$

dengan a ialah sebutan pertama, d ialah beza sepunya dan n ialah bilangan sebutan.
such that a is the first term, d is the common difference and n is the number of terms.

- (C) Cari nilai sebutan yang dinyatakan dalam setiap jangjang aritmetik yang berikut.
Find the value of the specific term stated in each of the following arithmetic progression.

(a) 13, 21, 29, 37, ...; Sebutan ke-21 / <i>The 21th term</i>	(b) 6, 11, 16, 21, ...; Sebutan ke-30 / <i>The 30th term</i>
--------------------------------------------------------------------------	-------------------------------------------------------------------------

(c) 32, 21, 10, -1, ...; Sebutan ke-26 / <i>The 26th term</i>	(d) -6, -3, 0, 3, ...; Sebutan ke-60 / <i>The 60th term</i>
(e) $y + 2, y, y - 2, \dots$; Sebutan ke-12 / <i>The 12th term</i>	(f) $\frac{1}{3}, \frac{7}{12}, \frac{5}{6}, \frac{13}{12}, \dots$; Sebutan ke-15 / <i>The 15th term</i>
(g) 2.4, 3.1, 3.8, 4.5, ...; Sebutan ke-10 / <i>The 10th term</i>	(h) $\frac{2}{3}, 1\frac{1}{6}, 1\frac{2}{3}, 2\frac{1}{6}, \dots$; Sebutan ke-17 / <i>The 17th term</i>

(D) Tentukan bilangan sebutan dalam jangjang aritmetik berikut:

Determine the number of terms of the following arithmetic progressions:

(a) 56, 70, 84, 98,, 266	(b) $3, \frac{5}{2}, 2, \dots, 0$
--------------------------------	-----------------------------------

(c) $-16, -11, -6, \dots, 24$	(d) $25, 21, 17, \dots, -19$
(e) $10x, 7x, 4x, \dots, -23x$	(f) $-\frac{1}{3}, -\frac{5}{6}, -\frac{3}{4}, \dots, -\frac{46}{3}$
(g) $2, 6, 10, \dots, 82$	(h) $21, 18, 15, \dots, -66.$

(E) Selesaikan masalah berikut.

Solve the following problems.

<p>1. Tiga sebutan pertama suatu jangjang aritmetik ialah $k-2, k+2, 2k+1$. Cari nilai bagi k. <i>The first three terms of an arithmetic progression is $k-2, k+2, 2k+1$. Find the value of k.</i></p> <p>[5]</p>	<p>2. Tiga sebutan pertama suatu jangjang aritmetik ialah $k-3, 2k-3, k+1$. Cari nilai bagi k. <i>The first three terms of an arithmetic progression is $k-3, 2k-3, k+1$. Find the value of k.</i></p> <p>[2]</p>
------------------------------------------------------------------------------------------------------------------------------------------------------------------------------------------------------------------------------------------------------------------------	------------------------------------------------------------------------------------------------------------------------------------------------------------------------------------------------------------------------------------------------------------------------

<p>3. Sebutan ke-n bagi suatu jangjang aritmetik diberi oleh $T_n = 3n + 1$. Carikan</p> <p><i>The n^{th} term of an arithmetic progression is given by $T_n = 3n + 1$. Find the</i></p> <p>(a) sebutan pertama / <i>first term</i> (b) beza sepunya / <i>common difference</i></p>	<p>4. Sebutan ke-n bagi suatu jangjang aritmetik diberi oleh $T_n = 4n - 9$. Carikan</p> <p><i>The n^{th} term of an arithmetic progression is given by $T_n = 4n - 9$. Find the</i></p> <p>(a) sebutan pertama / <i>first term</i> (b) beza sepunya / <i>common difference</i></p>
<p>[4 ; 3]</p> <p>5. Diberi suatu jangjang aritmetik 2, 6, 10, 14, Cari nilai n yang terkecil sedemikian sebutan ke-n jangjang ini adalah lebih besar daripada 100. <i>Given an arithmetic progression 2, 6, 10, 14,</i> <i>Calculate the smallest n such that the n^{th} term of this progression is greater than 100.</i></p>	<p>[-5 ; 6]</p> <p>6. Diberi suatu jangjang aritmetik -12, -9, -6, -3, Cari nilai n yang terbesar sedemikian sebutan ke-n jangjang ini adalah lebih kecil daripada 200. <i>Given an arithmetic progression -12, -9, -6, -3,</i> <i>Calculate the smallest n such that the n^{th} term of this progression is less than 200.</i></p>
<p>[26]</p> <p>7. Sebutan ke-3 dan sebutan ke-8 suatu jangjang aritmetik ialah 6 dan 31 masing-masing. Cari sebutan pertama dan beza sepunya jangjang aritmetik itu. <i>The 3th term and 8th term of an arithmetic progression is 6 and 31 respectively. Find the first term and common difference of the arithmetic progression.</i></p>	<p>[71]</p> <p>8. Sebutan ke-4 dan sebutan ke-9 suatu jangjang aritmetik ialah 9 dan 29 masing-masing. Cari sebutan pertama dan beza sepunya jangjang aritmetik itu. <i>The 4th term and 9th term of an arithmetic progression is 9 and 29 respectively. Find the first term and common difference of the arithmetic progression.</i></p>
<p>[-4 ; 5]</p>	<p>[-3 ; 4]</p>

(F) Penyelesaian Masalah / *Problem Solving*

Dalam satu pameran buku, Siti ingin menyusun buku-buku di bahagian hadapan ruang pameran. Dia menyusun buku-buku itu secara meninggi dengan tebal buku pertama yang berada di bahagian paling bawah ialah 2 cm.

Setiap buku yang seterusnya mempunyai ketebalan yang sama, iaitu 1.5 cm. Cari

- (a) jumlah ketebalan buku itu apabila Siti menyusun 16 buah buku.
- (b) bilangan buku yang telah disusun apabila tinggi susunan buku ialah 30.5 cm.

In a book fair, Siti wants to arrange books at the front section. She arranges the books by stacking them with the first book at 2 cm thickness at the bottom. However, the subsequent books have the same thickness, which is 1.5 cm. Find :

- (a) the total thickness of the books if Siti arranged 16 books.*
- (b) the number of books if the height of the books is 30.5 cm.*

Penyelesaian / Solutions :

(a)

(b)

Latih Diri 5.2 [MS 132] / *Self Practice 5.2 [PAGE 132]*

HASIL PEMBELAJARAN / LEARNING OUTCOMES

5.1.4 Mencari / *Finding* :

- a) hasil tambah n sebutan pertama bagi sesuatu jangjang aritmetik,
the sum of the first n terms of an arithmetic progression,
- b) hasil tambah beberapa sebutan tertentu yang berturutan bagi sesuatu jangjang aritmetik,
the sum of some specific consecutive terms of an arithmetic progression,
- c) nilai n , apabila hasil tambah n sebutan pertama bagi sesuatu jangjang aritmetik diberi.
the value of n , when the sum of the first n terms of an arithmetic progression is given.

Menerbitkan rumus hasil tambah n sebutan pertama, S_n bagi jangjang aritmetik

Deriving the formula of sum of the first n terms, S_n of the arithmetic progression

Pertimbangkan JA yang terdiri daripada n sebutan yang mempunyai urutan seperti berikut :

Consider an AP that consists of n terms follows the order as below :

$$a, a + d, a + 2d, \dots, a + (n - 1) \times d$$

Katakan hasil tambah n sebutan pertama itu ialah S_n .

Assume that the sum of the first n term is S_n .

Maka / Then : $S_n = a + (a + d) + \dots + [a + (n-2)d] + [a + (n-1)d]$ -----(1)

Seterusnya, kita tulis semula hasil tambah di atas dalam urutan songsang.

Hence, we can rewrite the sum of first n term above in the reverse order.

$$S_n = [a + (n-1)d] + [a + (n-2)d] + \dots + (a + d) + a \text{ -----(2)}$$

Tambahkan kedua-dua persamaan di atas :

Sum up both the above equations :

(1) + (2) :

$$S_n = a + (a+d) + \dots + (a + (n-2)d) + (a + (n-1)d)$$

$$S_n = (a + (n-1)d) + (a + (n-2)d) + \dots + (a + d) + a$$

$$2S_n = (2a + (n-1)d) + (2a + (n-1)d) + \dots + (2a + (n-1)d) + (2a + (n-1)d)$$

$$2S_n = n \times [2a + (n-1) \times d]$$

$$S_n = \frac{n}{2} [2a + (n-1) \times d]$$



$$S_n = \frac{n}{2} (\text{sebutan pertama / the first term} + \text{sebutan terakhir / the last term})$$

$$= \frac{n}{2} (a + l)$$

1. Cari hasil tambah jangjang aritmetik berikut.

Find the sum of the first n terms of the following.

<p>(a) 13, 21, 29, 37, ... ; <i>bagi 20 sebutan pertama / for the first 20 terms</i></p>	<p>(b) 6, 11, 16, 21, ... ; <i>bagi 25 sebutan pertama / for the first 25 terms</i></p>
<p>(c) $\frac{1}{3}, \frac{7}{12}, \frac{5}{6}, \frac{13}{12}, \dots$; <i>bagi n sebutan pertama / for the first n terms</i></p>	<p>(d) -6, -3, 0, 3, ... ; <i>bagi n sebutan pertama / for the first n terms</i></p>

<p>(e) 2, 6, 10, 14, ..., 54</p> <p>[guna rumus / use formula : $S_n = \frac{n}{2} (a + l)$]</p>	<p>(f) 21, 18, 15, 12, ..., -30</p>
<p>(g) 23, 17, 11, ..., -25</p>	<p>(h) -6, 1, 8, 15, ..., 127</p>

2. Cari hasil tambah janjang aritmetik berikut.

Find the sum of the specific consecutive terms of the following arithmetic progressions.

<p>(a) 9, 13, 17, 21,...</p> <p>(sebutan ke-4 hingga ke-24 / <i>from the 4th term to the 24th term</i>)</p>	<p>(b) 2, 6, 10, 14, ...</p> <p>(sebutan ke-5 hingga ke-16 / <i>from the 5th term to the 16th term</i>)</p>
<p>(c) 263, 257, 251, 245,....</p> <p>(sebutan ke-8 hingga ke-15 / <i>from the 8th term to the 15th term</i>)</p>	<p>(d) 21, 18, 15, 12, ...</p> <p>(sebutan ke-7 hingga ke-18 / <i>from the 7th term to the 18th term</i>)</p>

<p>(e) 13, 18, 23, 28,...</p> <p>(sebutan ke-5 hingga ke-23 / <i>from the 5th term to the 23th term</i>)</p>	<p>(f) -6, 1, 8, 15, ...</p> <p>(sebutan ke-9 hingga ke-20 / <i>from the 9th term to the 20th term</i>)</p>
<p>(g) -12, -9, -6, -3,...</p> <p>(sebutan ke-20 hingga ke-35 / <i>from the 20th term to the 35th term</i>)</p>	<p>(h) 6.7, 5.3, 3.9, ...</p> <p>(sebutan ke-7 hingga ke-14 / <i>from the 7th term to the 14th term</i>)</p>

3. Tentukan bilangan sebutan dalam jangjang aritmetik berikut.

Determine the number of terms in the following arithmetic progression.

<p>(a) 9, 13, 17, 21, ... ; Diberi / <i>Given</i> $S_n = 270$.</p>	<p>(b) 2, 6, 10, 14, ... Diberi / <i>Given</i> $S_n = 800$.</p>
-------------------------------------------------------------------------------	----------------------------------------------------------------------------

(c) 0.9, 1.8, 2.7, 3.6,... Diberi / Given $S_n = 504.9$.

(d) 21, 18, 15, 12,... Diberi / Given $S_n = 0$.

(e) 13, 18, 23, 28,... Diberi / Given $S_n = 153$.

(f) -6, 1, 8, 15, ... Diberi / Given $S_n = 553$.

(g) -12, -9, -6, -3,... Diberi / Given $S_n = 378$.

(h) 6.7, 5.3, 3.9, ... Diberi / Given $S_n = -93.6$.

4. Selesaikan masalah berikut. / Solve the following problems.

<p>1. Bagi suatu jangjang aritmetik 2, 6, 10, 14, ..., cari nilai n, diberi hasil tambah n sebutan pertamanya adalah 800. <i>For an arithmetic progression 2, 6, 10, 14, ..., find the value of n, given the sum of the first n terms is 800.</i></p> <p>[20]</p>	<p>2. Bagi suatu jangjang aritmetik 21, 18, 15, 12, ..., cari nilai n diberi hasil tambah n sebutan pertamanya, -81. <i>For an arithmetic progression 21, 18, 15, 12, ..., find the value of n, given the sum of the first n terms is -81.</i></p> <p>[18]</p>
<p>3. Hasil tambah n sebutan pertama bagi suatu jangjang aritmetik diberi oleh $S_n = 2n^2 + n$. Carikan <i>Sum of the first n terms of an arithmetic progression is given by $S_n = 2n^2 + n$. Find</i></p> <p>(a) sebutan pertama / <i>the first term</i> (b) beza sepunya / <i>the common difference</i></p> <p>[3 ; 4]</p>	<p>4. Hasil tambah n sebutan pertama bagi suatu jangjang aritmetik diberi oleh $S_n = 2n^2 - 5n$. Carikan <i>Sum of the first n terms of an arithmetic progression is given by $S_n = 2n^2 - 5n$. Find</i></p> <p>(a) sebutan pertama / <i>the first term</i> (b) beza sepunya / <i>the common difference</i></p> <p>[-3; 4]</p>
<p>5. Diberi suatu jangjang aritmetik 2, 6, 10, 14, Cari nilai n yang terkecil supaya hasil tambah n sebutan pertamanya lebih besar daripada 200. <i>Given an arithmetic progression 2, 6, 10, 14, Find the smallest n such that the sum of the first n terms is greater than 200.</i></p> <p>[11]</p>	<p>6. Diberi suatu jangjang aritmetik -12, -9, -6, -3, Cari nilai n yang terkecil supaya hasil tambah n sebutan pertamanya lebih besar daripada 243. <i>Given an arithmetic progression -12, -9, -6, -3, Find the smallest n such that the sum of the first n terms is greater than 243.</i></p> <p>[19]</p>

<p>7. Sebutan pertama dan terakhir suatu jangjang aritmetik adalah 3 dan 21 masing-masing dan hasil tambah semua sebutan siri itu adalah 240. Cari bilangan sebutannya. <i>The first and last term of an arithmetic progression is 3 and 21 respectively and the sum of all the terms in the series is 240. Find the number of terms in the series.</i></p> <p style="text-align: right;">[20]</p>	<p>8. Sebutan pertama dan terakhir suatu jangjang aritmetik adalah - 4 dan 18 masing-masing dan hasil tambah semua sebutan siri itu adalah 168. Cari bilangan sebutannya. <i>The first and last term of an arithmetic progression is -4 and 18 respectively and the sum of all the terms in the series is 168. Find the number of terms in the series.</i></p> <p style="text-align: right;">[24]</p>
<p>9. Hasil tambah 4 sebutan pertama suatu jangjang aritmetik ialah 36 dan hasil tambah bagi 10 sebutan seterusnya adalah 370. Cari nilai sebutan pertama dan beza sepunya. <i>The sum of the first 4 terms of an arithmetic progression is 36 and the sum of the next 10 terms is 370. Find the first term and its common difference.</i></p> <p style="text-align: right;">[3 ; 4]</p>	<p>10. Hasil tambah 6 sebutan pertama suatu jangjang aritmetik ialah 36 dan hasil tambah bagi 12 sebutan seterusnya adalah 558. Cari nilai sebutan pertama dan beza sepunya. <i>The sum of the first 6 terms of an arithmetic progression is 36 and the sum of the next 12 terms is 558. Find the first term and its common difference.</i></p> <p style="text-align: right;">[-3 ; 4]</p>
<p>11. Dalam suatu jangjang aritmetik, sebutan ke-6 ialah 23 dan hasil tambah 6 sebutan pertamanya ialah 78. Cari sebutan pertama dan beza sepunya. <i>In an arithmetic progression, the 6th term is 23 and the sum of the first 6 terms is 78. Find the first term and its common difference.</i></p> <p style="text-align: right;">[3 ; 4]</p>	<p>12. Dalam suatu jangjang aritmetik, sebutan ke-8 ialah 25 dan hasil tambah 6 sebutan pertamanya ialah 88. Cari sebutan pertama dan beza sepunya. <i>In an arithmetic progression, the 8th term is 25 and the sum of the first 6 terms is 88. Find the first term and its common difference.</i></p> <p style="text-align: right;">[-3 ; 4]</p>

13. Suatu jangjang aritmetik mempunyai 20 sebutan. Diberi sebutan ke-8 ialah 25 dan hasil tambah 8 sebutan terakhirnya ialah 404. Cari

An arithmetic progression has 20 terms. Given the 8th Term is 25 and the sum of the last 8 terms is 404.

(a) Cari sebutan pertama dan beza sepunya.

Find the first term and its common difference.

(b) Cari hasil tambah 8 sebutan pertamanya.

Find the sum of the first 8 terms.

14. Sebutan pertama suatu JA ialah 2. Hasil tambah 8 sebutan pertamanya ialah 58 dan hasil tambah bagi semua sebutan ialah 325. Cari

The first term of an AP is 2. The sum of the first 8 terms is 58 and the sum of all the terms is 325.

(a) Cari beza sepunya.

Find the common difference.

(b) Cari bilangan sebutannya.

Find the number of terms.

5. Penyelesaian masalah (Soalan panjang) / *Problem solving (Long Question)*

1. Sekumpulan lebah mula membuat satu sarang lebah yang baharu. 2 lubang heksagon dibuat pada hari pertama, 5 lubang heksagon pada hari kedua, 8 lubang heksagon pada hari ketiga dan seterusnya sehingga sarang lebah itu siap sepenuhnya. Hitung

A swarm of bees started to make a new beehive. 2 hexagonal holes were made on the first day, 5 hexagonal holes were made on the second day, 8 hexagonal holes on the third day and followed on until the beehive is ready. Calculate

(a) jumlah lubang heksagon pada hari ke-12,
the number of hexagonal holes on the 12th day,

(b) bilangan minimum hari jika lebih daripada 1 000 lubang heksagon telah dibuat.
the minimum number of days if there are more than 1000 hexagonal holes made.

Penyelesaian / *Solutions* :

2. Encik Suhaimi, seorang penternak ayam mempunyai 1 500 ekor ayam. Dia bercadang untuk menjual 200 ekor ayam setiap hari. Dia memberi makanan kepada semua ayam itu dengan perbelanjaan makanan bagi seekor ayam ialah RM0.50 sehari. Hitung jumlah kos perbelanjaan makanan ayam yang diperuntukkan oleh Encik Suhaimi bermula daripada 1 500 ekor ayam yang ada hingga 300 ekor ayam yang tinggal.
Mr. Suhaimi is a chicken breeder that has 1500 chickens. He plans to sell 200 chickens each day. He gives food to all the chickens with the expenses of RM0.50 per chicken in a day. Calculate the total expenses of the food spent by Mr. Suhaimi if he starts with 1500 chickens until he is left with 300 chickens.

Penyelesaian / *Solutions* :

Latih diri 5.4 dan Latihan Intensif 5.1 [MS 138] / Self Practice 5.4 and Intensive Practice 5.1 [PAGE 138]

Menyelesaikan masalah yang melibatkan jangjang aritmetik. / *Solving problems involving arithmetic progressions*

Proses Penyelesaian Masalah / *Process of Problem Solving*

Langkah Pertama <i>First Step</i>	<p>MEMAHAMI MASALAH / <i>UNDERSTANDING THE PROBLEM</i> Baca dan kaji soalan untuk mengetahui maklumat yang diberikan dan maklumat yang dikehendaki. Tentukan sama ada maklumat yang diberikan mencukupi. Jika maklumat asas yang diberikan tidak mencukupi, apakah maklumat lanjutan yang diperlukan? Kalau boleh, lakarkan rajah daripada maklumat yang diberikan dan perkenalkan tata tanda yang akan digunakan.</p> <p><i>Read and study the question to identify the information given dan the information requested in the question. Determine if the information given is sufficient. If the basic information given is insufficient, what are the additional information needed? If possible, sketch the diagram based on the information given and introduce the symbols that are going to use.</i></p>
Langkah Kedua <i>Second Step</i>	<p>MEMPEROLEH RANCANGAN PENYELESAIAN / <i>PLANNING A STRATEGY</i> Carikan hubungan di antara data yang diberi dengan apa yang dikehendaki. Tentukan sama ada kamu pernah melihat masalah yang seumpama dengannya. Adakah kamu mengetahui teorem yang boleh kamu gunakan? Dapatkan rancangan penyelesaian.</p> <p><i>Find out the relationship between the data given and the information requested in the question. Determine whether you have seen such a similar problem before. Do you know the theorem that you can apply? Work out the strategy.</i></p>
Langkah Ketiga <i>Third Step</i>	<p>MENJALANKAN RANCANGAN PENYELESAIAN Jalankan rancangan penyelesaian dengan berhati-hati untuk memperoleh jawapan yang dikehendaki.</p> <p><i>Implement the strategy carefully to obtain the answers needed.</i></p>

Langkah Keempat <i>Fourth Step</i>	MENYEMAK SEMULA / RECHECK Kesilapan dan kesalahan mungkin berlaku dalam penyelesaian masalah. Semak penyelesaian untuk memastikan keputusannya betul. Banyak pengajaran yang boleh diperolehi daripada kesilapan atau kesalahan supaya tidak mengulanginya. <i>Errors and mistakes might occur in problem solving. Recheck the solutions to make sure its result is correct.</i> <i>We should learn from mistakes or errors so that we do not repeat the same mistakes or errors again.</i>
-------------------------------------------	----------------------------------------------------------------------------------------------------------------------------------------------------------------------------------------------------------------------------------------------------------------------------------------------------------------------------------------------------------------------------------------------------------------------------------------------------------------------------------------------------------------

Lembaran kerja Tambahan / Additional Worksheet

- (1) Satu tumbuhan bertambah tinggi dengan 0.5 cm setiap hari. Jika tinggi asalnya ialah 4 cm, berapa hari lagi ketinggiannya akan menjadi 175 cm?

A plant grows higher 0.5 cm everyday. If its original height is 4 cm, how many days later will the height of the plant reach 175 cm?

-
- (2) Rajah menunjukkan tiga segitiga yang dibentukkan oleh mancis. **Panjang setiap mancis ialah 5 cm.**
The diagram shows 3 triangles formed by matches. The length of each matches is 5 cm.

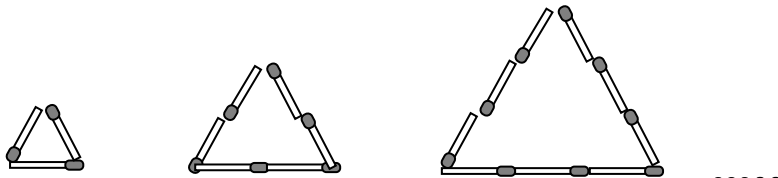

Perimeter bagi setiap segitiga membentuk jangjang aritmetik. Sebutan untuk jangjang mengikut tertib menaik.

Perimeter for each triangle forms arithmetic progression. The terms in the progression are in ascending order.

- (a) Tulis tiga sebutan pertama dalam jangjang ini. / *Write the first three terms in the progression.*
(b) Cari beza sepunya jangjang itu. / *Find its common difference.*

- (3) Pada **hari pertama**, isipadu air dalam sebuah tangki ialah **600 liter**. Setiap hari berikutnya, air dalam tangki itu **ditambah sebanyak 30 liter**. Hitungkan isipadu, dalam liter, air dalam tangki itu pada akhir **hari ke-10**.

On the first day, the volume of water in a tank is 600 litres. On every next following day, the water in the tank is added with another 30 litres each day. Calculate the volume, in litres, of water in the tank at the end of the 10th day.

- (4) Rajah di bawah menunjukkan tiga segiempat sama berturutan dalam susunan menaik.

The diagram below shows three consecutive squares in the ascending order.

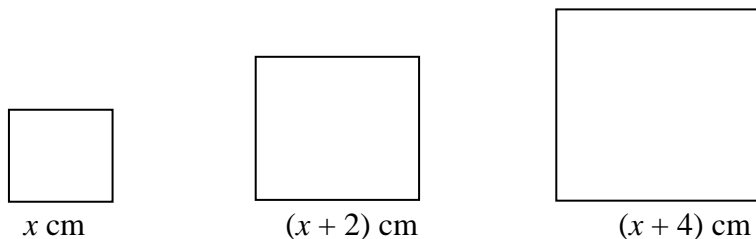

- (a) Tunjukkan **perimeter** bagi segiempat yang membentuk jantang aritmetik.

Seterusnya, nyatakan beza sepunya.

*Show that **the perimeter** of the squares forms arithmetic progression.*

Hence, state the common difference.

- (b) Diberi $x = 8$ cm, **cari**

*Given $x = 8$ cm, **find***

- (i) **hasil tambah** perimeter bagi 16 segiempat yang pertama.

***the sum** of the perimeter of the first 16 squares.*

- (ii) segiempat yang pertama mempunyai perimeter **melebihi 210 cm**.

*the first square that has perimeter **greater than 210 cm**.*

Jawapan / Answers :

Lembaran kerja 1 / Worksheet 1

(A)

(a) J.A / AP, $d = -6$	(b) Bukan J.A / Not an AP
(c) J.A / AP, $d = 12$	(d) J.A / AP, $d = 0.8$
(e) J.A / AP, $d = x - 2$	(f) Bukan J.A Not an AP

(C)

(a) 16	(b) 7
(e) 9	(f) 12
(e) 12	(f) 31
(g) 21	(h) 30

Lembaran kerja 2 / Worksheet 2

(A)

(a) 1780	(b) 1650
(g) $\frac{143}{6}$	(h) 39
(e) 392	(f) -81
(g) -9	(h) 1210

(C)

(a) 10	(b) 20
(i) 33	(j) 15
(e) 6	(f) 14
(g) 21	(h) 18

Lembaran Kerja 3 / Worksheet 3

(1) 342	(2) (a) 15, 30, 45 (b) $d = 15$	(3) 870	(4)(a) $d = 8$ (b) (i) 1472 (ii) $n = 24$
---------	------------------------------------	---------	-------------------------------------------------

(B)

(a) 173	(b) 151
(c) -243	(d) 171
(e) $y - 20$	(f) $\frac{23}{6}$
(g) 8.7	(h) $\frac{26}{3}$

(B)

(a) 1281	(b) 480
(c) 1600	(e) 0
(e) 1482	(f) 1062
(g) 963	(h) -52.8

Janjang Geometri / Geometric Progressions

$a, ar, ar^2, ar^3, \dots, ar^{n-1}$
 $T_1, T_2, T_3, T_4, \dots, T_n$

Sebutan ke-n / The nth term

$$T_n = ar^{n-1}$$

$$T_n = S_n - S_{n-1}$$

Hasil tambah n sebutan pertama / Sum of the first n terms

$$S_n = \frac{a(r^n - 1)}{r - 1}, r \neq 1 [r > 1]$$

$$S_n = \frac{a(1 - r^n)}{1 - r}, r \neq 1 [r < 1]$$

$$S_\infty = \frac{a}{1 - r}, [|r| < 1]$$

a = Sebutan pertama / First term
 r = Nisbah sepunya / Common ratio

$$= \frac{T_2}{T_1} = \frac{T_3}{T_2} = \dots = \frac{T_n}{T_{n-1}}$$

Kesilapan Umum
Common Error
 $\frac{T_1}{T_2} = \frac{T_2}{T_3}$

HASIL PEMBELAJARAN / LEARNING OUTCOMES

- 5.1.1 Mengenal pasti ciri-ciri sesuatu janjang Geometri.
Identifying properties of Geometric progressions.
- 5.1.2 Menentukan sama ada sesuatu jujukan yang diberi merupakan janjang Geometri.
Determining whether a sequence given is Geometric progression.
- 5.1.3 Menentukan dengan menggunakan formula / *Determining using formula :*
- a. sebutan tertentu dalam sesuatu janjang Geometri.
the specific term in a Geometric progression.
 - b. bilangan sebutan dalam satu janjang Geometri.
the number of terms of a Geometric progression.

5.2.1 / 5.2.2 Mengenal pasti janjang geometri / Identifying geometric progressions

- 1. Dalam jujukan Geometri setiap sebutan diperoleh dengan mendarab sebutan sebelumnya dengan pemalar.**
In a Geometri progression, every term is obtained by multiplying its previous term with a constant.

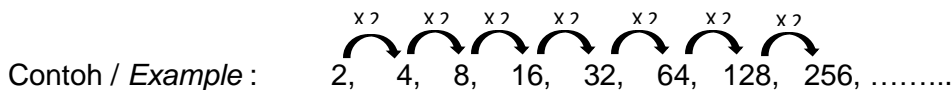

Setiap sebutan (kecuali sebutan pertama) didapati dengan mendarabkan 2 kepada sebutan sebelumnya.
Every term (except the first term) is obtained by multiplying 2 to its previous term.

Umumnya, Janjang Geometri boleh ditulis dalam bentuk / *Generally, Geometric Progression can be written in the form :*

$$\{ a, ar, ar^2, ar^3, \dots \}$$

Di mana / where :

- a merupakan sebutan pertama / *a is the first term.*
- r adalah faktor antara sebutan dan disebut sebagai "nisbah sepunya"
r is factor between terms and it is addressed as "common ratio"

5.2.3 Menerbitkan rumus sebutan ke-n, T_n bagi jajang geometri

Deriving the formula for the nth term of geometric progression, GP.

Contoh / Example : Pertimbangkan jajang geometri berikut

Consider the following geometric progression

$$\{ 1, 2, 4, 8, \dots \}$$

Jujukan ini bermula dengan 1 dan berganda bagi sebutan berikutnya. Maka,

This sequence starts from 1 and is doubled for its subsequent terms. Hence,

- $a = 1$ (sebutan pertama / the first term)
- $r = \frac{2}{1} = 2$ (nisbah sepunya yang berganda bagi setiap sebutan / common ratio that doubles its the subsequent terms)

Lengkapkan jadual berikut / Complete the following table :

Sebutan <i>Term</i>	Nilai Sebutan <i>Value of Term</i>	Kaedah mendapatkan nilai sebutan <i>Method to get the value of term</i>	Rumus <i>Formula</i>
T_1	1	1	a
T_2	2	1×2^1	ar^{2-1}
T_3	4	1×2^2	ar^{3-1}
T_4	8	1×2^3	ar^{4-1}
\vdots	\vdots	\vdots	\vdots
T_n			ar^{n-1}

Peringatan, r tidak boleh = 0 / *Reminder, r cannot = 0*

- Bila $r = 0$, jujukan akan menjadi $\{a, 0, 0, \dots\}$ dan ini bukan lagi geometri.
When $r = 0$, the sequence will be $\{a, 0, 0, \dots\}$ and this will not be geometry.

Rumus / Formula

Pada dasarnya, kita boleh mengira **sebarang sebutan** menggunakan rumus:

Basically, we can calculate any term using formula :

$$T_n = ar^{(n-1)}$$



(" n - 1" kerana ar^0 adalah untuk sebutan pertama sahaja.)

("n - 1" because ar^0 is for the first term only.)

dan Nisbah sepunya / and common Ratio

$$\left[r = \frac{T_2}{T_1} = \frac{T_3}{T_2} = \dots = \frac{T_n}{T_{n-1}} \right]$$

1. Nyatakan nisbah sepunya bagi JG berikut. / State the common ratio of the following GP.

<p>1. 2, 6, 18, 54, ...</p> <p style="text-align: right;">[3]</p>	<p>2. 3, 12, 48, 192, ...</p> <p style="text-align: right;">[4]</p>	<p>3. $2p, 4p^2, 8p^3, \dots$</p> <p style="text-align: right;">[2p]</p>
<p>4. 1458, 486, 162, 54, ...</p> <p style="text-align: right;">[$\frac{1}{3}$]</p>	<p>5. 192, -96, 48, -24, ...</p> <p style="text-align: right;">[$-\frac{1}{2}$]</p>	<p>6. $1\frac{1}{2}, 2\frac{1}{4}, 3\frac{3}{8}, \dots$</p> <p style="text-align: right;">[3/2]</p>

2. Tentukan sama ada setiap yang berikut adalah janjang geometri atau tidak.

Determine if each of the following is a geometric progression.

<p>(a) 3, 9, 27, 81,</p>	<p>(e) -20, 10, -5,</p>	<p>(c) $a, \frac{1}{2}a, \frac{1}{4}a, \dots$</p>
--------------------------------	-------------------------------	--------------------------------------------------------------

3. Jujukan yang berikut ialah tiga sebutan pertama bagi JG. Cari nilai-nilai x.

The following sequences are the first three terms of an GP. Find the values of x.

<p>1. $x, x+3, x+9$</p> <p style="text-align: right;">[3]</p>	<p>2. $x-1, x+2, x+8$</p> <p style="text-align: right;">[4]</p>	<p>3. $x-4, x, 5x-12$</p> <p style="text-align: right;">[2, 6]</p>
--------------------------------------------------------------------------	----------------------------------------------------------------------------	-------------------------------------------------------------------------------

4. Cari sebutan ke-5 dan sebutan ke-10 bagi jangjang geometri yang berikut.

Find the 5th term and the 10th term of the following geometric progression.

<p>1. 2, 6, 18, 54, ...</p> <p>$a =$ dan $r =$</p> <p>$T_n = ar^{n-1}$</p> <p>$T_5 =$ $T_{10} =$</p> <p style="text-align: right;">[162 ; 39366]</p>	<p>2. 3, 12, 48, 192, ...</p> <p>$a =$ dan $r =$</p> <p>$T_n = ar^{n-1}$</p> <p>$T_5 =$ $T_{10} =$</p> <p style="text-align: right;">[768 ; 786432]</p>
<p>3. 1458, 486, 162, 54, ...</p> <p style="text-align: right;">[18 ; $\frac{2}{27}$]</p>	<p>4. 192, -96, 48, -24, ...</p> <p style="text-align: right;">[12 ; $-\frac{3}{8}$]</p>

(e) Cari bilangan sebutan bagi setiap jangjang geometri di bawah.

Find the number of terms in the following geometric progression.

<p>1. 2, 6, 18, ..., 1458</p> <p>$a =$, $r =$ dan $T_n =$</p> <p>$ar^{n-1} = T_n$</p> <p style="text-align: right;">[6]</p>	<p>2. 3, 12, 48, ..., 3072.</p> <p>$a =$, $r =$ dan $T_n =$</p> <p>$ar^{n-1} = T_n$</p> <p style="text-align: right;">[6]</p>
------------------------------------------------------------------------------------------------------------------------------------------------------------------------------------------------	--------------------------------------------------------------------------------------------------------------------------------------------------------------------------------------------------

3. 1458, 486, 162, ..., 2

[7]

4. 192, -96, 48, ..., $\frac{1}{64}$

[7]

5. Latihan Pengayaan / Enrichment Exercises

1. Sebutan ke-n suatu JG diberikan sebagai $T_n = 2^{2n-1}$. Cari
The n^{th} term of a GP is given by $T_n = 2^{2n-1}$. Find
(a) sebutan pertama (b) nisbah sepunya
the first term its common difference

[2 ; 3]

2. Sebutan ke-n suatu JG diberikan sebagai $T_n = 3^{3n-2}$. Cari
The n^{th} term of a GP is given by $T_n = 3^{3n-2}$. Find
(a) sebutan pertama (b) nisbah sepunya
the first term its common difference

[3 ; 27]

3. Diberi sebutan ke-2 dan ke-5 suatu JG ialah 12 dan 96 masing-masing. Cari
Given the 2th term and the 5th term of a GP is 12 and 96 respectively. Find
(a) sebutan pertama (b) nisbah sepunya
the first term its common difference

[±3 ; ±2]

4. Diberi sebutan ke-3 dan ke-6 suatu JG ialah 108 dan 2916 masing-masing. Cari
Given the 3th term and the 6th term of a GP is 108 and 2916 respectively. Find
(a) sebutan pertama (b) nisbah sepunya
the first term its common difference

[9]

5. Diberi suatu jangjang geometri 2, 6, 18, 54, ...
Given a geometric progression 2, 6, 18, 54, ...
 Cari nilai terkecil bagi n supaya sebutan ke-n lebih besar daripada 100000.
Find the smallest value of n such that the n^{th} term is greater than 100000.

[13]

5. Diberi suatu jangjang geometri 3, 12, 48, 192, ...
Given a geometric progression 3, 12, 48, 192, ...
 Cari nilai terkecil bagi n supaya sebutan ke-n lebih besar daripada 180000.
Find the smallest value of n such that the n^{th} term is greater than 180000.

[9]

Latih Diri 5.5 dan Latih Diri 5.6 [MS 141 dan MS 143] / *Self Practice 5.5 and Self Practice 5.6 [PAGE 141 and PAGE 143]*

5.2.1 Menerbitkan rumus hasil tambah n sebutan pertama, S_n bagi jangjang geometri

Deriving the formula of sum of the first n terms, S_n of the geometric progression

Anggaplah bahawa kita ingin mencari hasil tambah n sebutan pertama bagi suatu jangjang geometri. Apa yang kita dapatkan adalah

Assume that we wish to find the sum of the first n term of an geometri progression. What we will get is

$$S_n = a + ar + ar^2 + ar^3 + \dots + ar^{n-1}, \text{ ----} \rightarrow (1)$$

dan ini dipanggil siri geometri. Sekarang, cara untuk mencari jumlahnya adalah dengan mendarabkan dengan r dan kemudian tolak (2) daripada (1):

and this is called geometric series. Now, the method to find its total is by multiplying with r and then subtract (2) from (1):

$$S_n = a + ar + ar^2 + ar^3 + \dots + ar^{n-1}$$

$$(1) \times r \rightarrow rS_n = ar + ar^2 + ar^3 + \dots + ar^{n-1} + ar^n \text{ ----} \rightarrow (2)$$

$$(1) - (2) \rightarrow S_n - rS_n = a - ar^n$$

Maka / Hence,

$$S_n(1 - r) = a(1 - r^n).$$

Sekarang, bahagi dengan $1 - r$ (asalkan $r \neq 1$) untuk mendapatkan
Now, divide with $1 - r$ (provided $r \neq 1$) to get

$$S_n = \frac{a(1 - r^n)}{1 - r}.$$

Cuba (2) - (1) dan lihat apa anda dapat?

Try (2) - (1) and see what will you get?

***** Dalam suatu jangjang geometri, sebutan ke- n [T_n] boleh juga dihitung dengan menolak hasil tambah sebutan ke- n , [S_n] dengan hasil tambah sebutan ke- $(n - 1)$, [S_{n-1}].

***** *In a geometric progression, the n^{th} term [T_n] can be calculated by subtracting the sum of the first n terms, [S_n] With the sum of the first $(n-1)$ terms, [S_{n-1}].*

Misalnya, diberi jangjang geometri 1, -3, 9, -27, ...

For example, given geometric progression 1, -3, 9, -27, ...

Sebutan ke-5 boleh dihitung dengan menolak hasil tambah lima sebutan pertama dengan hasil tambah empat sebutan pertama, iaitu $T_5 = S_5 - S_4$.

The 5th term can be calculated by subtracting the sum of the first five terms with the sum of the first four terms, that is $T_5 = S_5 - S_4$.

Maka, umumnya rumus untuk mencari T_n dengan menggunakan hasil tambah sebutan boleh ditulis sebagai:

Hence, generally the formula for finding T_n by using the sum of the terms can be written as :

$$T_n = S_n - S_{n-1}$$

**5.2.1 HASIL TAMBAH DALAM JANJANG GEOMETRI
THE SUM OF TERMS IN GEOMETRIC PROGRESSIONS**

**(a) Cari hasil tambah sebutan n yang pertama bagi setiap jangjang geometri yang berikut.
Find the sum of the first n terms of the following geometric progressions.**

<p>1) 2, 6, 18, 54, ... n = 8 a = dan r =</p> $S_n = \frac{a(r^n - 1)}{r - 1}$ <p>$S_8 =$</p> <p style="text-align: right;">[6560]</p>	<p>2). 6, -18, 54, n = 6</p> <p style="text-align: right;">[-1092]</p>
<p>3). 12, 48, 192, n = 7</p> <p style="text-align: right;">[65 532]</p>	<p>4) 8, -4, 2, n = 9</p> <p style="text-align: right;">[5.344]</p>

(b) Cari hasil tambah semua sebutan dalam setiap JG yang berikut.

Find the sum of all the terms in each of the following GP.

<p>1. 2, 6, 18, ..., 4374</p> <p>$a =$ $r =$ dan $T_n =$</p> <p>Cari n dahulu,</p> <p>$ar^{n-1} = T_n$ $S_n = \frac{a(r^n - 1)}{r - 1}$</p> <p>= $S_{(\quad)} =$</p> <p style="text-align: right;">[2186]</p>	<p>2. 3, 12, 48, ..., 3072.</p> <p style="text-align: right;">[4095]</p>
<p>3. 1458, 486, 162, ..., 2</p> <p style="text-align: right;">[2186]</p>	<p>4. 192, -96, 48, ..., $\frac{3}{4}$</p> <p style="text-align: right;">[129]</p>

(c) Cari hasil tambah bagi sebutan-sebutan tertentu bagi JG di bawah.

Find the sum of the specific terms of the following GP.

<p>1) JG / GP : 2, 6, 18, 54, ...</p> <p>Cari hasil tambah dari sebutan ke-5 hingga sebutan ke-9.</p> <p><i>Find the sum from the 5th to 9th terms.</i></p> <p>$a =$ dan $r =$</p> <p>$S_9 - S_4 =$</p> <p style="text-align: right;">[19602]</p>	<p>2) JG / GP : 3, 12, 48, 192, ...</p> <p>Cari hasil tambah dari T_6 hingga T_{10}.</p> <p><i>Find the sum from the 6th to 10th terms</i></p> <p style="text-align: right;">[1047552]</p>
-------------------------------------------------------------------------------------------------------------------------------------------------------------------------------------------------------------------------------------------------------------------------------------------------------------------------------	--------------------------------------------------------------------------------------------------------------------------------------------------------------------------------------------------------------------------------------------

<p>3) JG / GP : 1458, 486, 162, 54, ... Cari hasil tambah dari sebutan ke-5 hingga sebutan ke-8. <i>Find the sum from the 5th to 8th terms.</i></p> <p style="text-align: right;">[26.67]</p>	<p>4) JG / GP : 192, -96, 48, -24, ... Cari hasil tambah dari T_7 hingga T_{10}. <i>Find the sum from the 7th to 10th terms.</i></p> <p style="text-align: right;">[1.875]</p>
-----------------------------------------------------------------------------------------------------------------------------------------------------------------------------------------------------------------------------	----------------------------------------------------------------------------------------------------------------------------------------------------------------------------------------------------------------------------------------

(d) Cari nilai n, diberi hasil tambahan n sebutan pertama bagi JG yang berikut.
Find the value of n, given the sum of the first n terms of the following GP.

<p>1) JG / GP : -2, -6, -18, dan / and $S_n = -59\ 048$.</p> <p>$a =$ dan $r =$</p> $\frac{a(r^n - 1)}{r - 1} = S_n$ <p style="text-align: right;">[n=10]</p>	<p>2) JG / GP : 3, 12, 48, dan hasil tambah n sebutan ialah 16 383. <i>and the sum of the first n terms is 16383.</i></p> <p>$a =$ dan $r =$</p> $\frac{a(r^n - 1)}{r - 1} = S_n$ <p style="text-align: right;">[n=7]</p>
<p>3) JG / GP : $\frac{3}{8}, \frac{3}{4}, \frac{3}{2}, \dots$ dan $S_n = 11\frac{5}{8}$.</p> <p style="text-align: right;">[n=5]</p>	<p>4) 2, 1, $\frac{1}{2}, \dots$ dan hasil tambah n sebutan ialah $\frac{127}{32}$. $2, 1, \frac{1}{2}, \dots$ and the sum of the first n terms is $\frac{127}{32}$.</p> <p style="text-align: right;">[n=7]</p>

(e) Penyelesaian Masalah / Problem Solvings

Sebuah syarikat produk kesihatan telah merancang satu strategi pemasaran. Setiap ahli perlu mempromosikan produk keluaran syarikat dengan mendapatkan dua orang ahli di bawahnya.

A health product company has planned a marketing strategy. Each member has to promote the company products by getting two downlines.

(a) Tunjukkan bahawa bilangan ahli bagi setiap tahap adalah suatu jangjang geometri.

Show that the number of members in each level forms a geometric progression.

(b) Jika terdapat 9 tahap dalam suatu strategi pemasaran,

cari jumlah ahli yang terlibat dalam mempromosikan produk itu.

If there are 9 levels in the marketing strategy, find the total number of members involved in promoting the products.

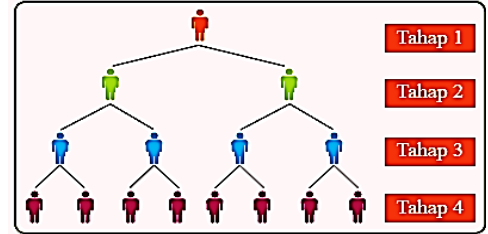

Penyelesaian / Solutions :

Latih Diri 5.4 [MS 145] / Self Practice 5.4 [PAGE 145]

5.2.2 Menentukan hasil tambah ketakterhinggaan bagi jangjang geometri

Determine the sum to infinity of geometric progression

1. Pertimbangkan jangjang geometri 64, 32, 16, ...

Consider geometric progression 64, 32, 16, ...

2. Lengkapkan jadual di sebelah bagi nilai r^n dan S_n .

Complete the table on the right for the values of r^n dan S_n .

3. Bincang bersama-sama ahli kumpulan tentang pemerhatian anda pada kedua-dua nilai ini apabila n semakin bertambah.

Discuss together with group members about your observations on the two values when n increases.

4. Buat satu kesimpulan bagi $S_n = \frac{a(r^n-1)}{r-1}$ apabila n bertambah hingga ketakterhinggaan. Seterusnya, ungkapkan S_∞ dalam sebutan a dan r .

Derive a conclusion for $S_n = \frac{a(r^n-1)}{r-1}$ when n increases to infinity. Then, express S_∞ in term of a and r .

n	r^n	S_n
1		
2		
3		
4		
5		
10		
20		
100		
200		

Dapatan / Findings :

(e) Hasil Tambah Sehingga Ketakhinggaan, S_∞ / The Sum to Infinity, S_∞

(I) Cari hasil tambah sehingga ketakterhinggaan, S_∞ bagi setiap JG yang berikut.

Find the sum to infinity, S_∞ for each of the following GP.

<p>1. 8, 4, 2, 1, ...</p> <p>$a =$ dan $r =$</p> <p>$S_\infty = \frac{a}{1-r}$</p> <p>=</p> <p>[16]</p>	<p>2. 27, 9, 3, 1, ...</p> <p>$a =$ dan $r =$</p> <p>$S_\infty = \frac{a}{1-r}$</p> <p>=</p> <p>[40.5]</p>
<p>3. 1458, 486, 162, 54, ...</p> <p>[2187]</p>	<p>4. 192, -96, 48, -24, ...</p> <p>[128]</p>

(II) Cari sebutan pertama, a atau nisbah sepunya, r jika diberi hasil tambah hingga ketakhinggaan S_∞ .

Find the first term, a or the common ratio, r if given the sum to infinity, S_∞ .

<p>1. Sebutan pertama dan hasil tambah sehingga ketakhinggaan suatu jangjang geometri ialah 4 dan 8. Cari nisbah sepunya. <i>The first term and the sum to infinity of a geometric progression is 4 and 8. Find the common ratio.</i></p> <p>[$\frac{1}{2}$]</p>	<p>2. . Sebutan pertama dan hasil tambah sehingga ketakhinggaan suatu jangjang geometri ialah 5 dan 15. Cari nisbah sepunya. <i>The first term and the sum to infinity of a geometric progression is 5 and 15. Find the common ratio.</i></p> <p>[$\frac{2}{3}$]</p>
---------------------------------------------------------------------------------------------------------------------------------------------------------------------------------------------------------------------------------------------------------------------------------	-------------------------------------------------------------------------------------------------------------------------------------------------------------------------------------------------------------------------------------------------------------------------------------

<p>3. Nisbah sepunya dan hasil tambah hingga ketaklinggan suatu JG ialah $\frac{1}{3}$ dan 30 masing-masing. Cari sebutan pertama. <i>The common ratio and the sum to infinity of a GP is $\frac{1}{3}$ and 30 respectively. Find the first term.</i></p> <p style="text-align: right;">[20]</p>	<p>4. Nisbah sepunya dan hasil tambah hingga ketaklinggan suatu JG ialah $-\frac{1}{4}$ dan 20 masing-masing. Cari sebutan pertama. <i>The common ratio and the sum to infinity of a GP is $-\frac{1}{4}$ and 20 respectively. Find the first term.</i></p> <p style="text-align: right;">[25]</p>
-----------------------------------------------------------------------------------------------------------------------------------------------------------------------------------------------------------------------------------------------------------------------------------------------------------------------------	-------------------------------------------------------------------------------------------------------------------------------------------------------------------------------------------------------------------------------------------------------------------------------------------------------------------------------

(III) Ungkapkan setiap nombor perpuluhan jadi semula berikut kepada bentuk pecahan termudah.
Express each of the following recurring decimals as a fraction in the simplest form.

<p>1. 0.5555...</p> <p style="text-align: right;">[$\frac{5}{9}$]</p>	<p>2. 0.7777...</p> <p style="text-align: right;">[$\frac{7}{9}$]</p>
<p>3. 0.060606...</p> <p style="text-align: right;">[$\frac{2}{33}$]</p>	<p>4. 0.020202...</p> <p style="text-align: right;">[$\frac{2}{99}$]</p>
<p>5. 0.0363636...</p> <p style="text-align: right;">[$\frac{2}{55}$]</p>	<p>6. 0.345345345...</p> <p style="text-align: right;">[$\frac{115}{333}$]</p>

<p>7. 3.018</p> <p style="text-align: right;">[3 $\frac{1}{55}$]</p>	<p>8. 5.012</p> <p style="text-align: right;">[5 $\frac{4}{33}$]</p>
---------------------------------------------------------------------------------	---------------------------------------------------------------------------------

<p>(f) Latihan Pengayaan / Enrichment Exercises</p>	
<p>1. Hasil tambah n sebutan pertama, S_n, bagi suatu JG diberi oleh $S_n = 4^n - 1$. Cari</p> <p><i>The sum of the first n terms, S_n, of a GP is given by $S_n = 4^n - 1$. Find</i></p> <p>(a) sebutan pertama / <i>the first term.</i> (b) nisbah sepunya / <i>its common ratio.</i></p> <p style="text-align: right;">[a=3 r=4]</p>	<p>2. Hasil tambah n sebutan pertama, S_n, bagi suatu JG diberi oleh $S_n = 1 - (-3)^n$. Cari</p> <p><i>The sum of the first n terms, S_n, of a GP is given by $S_n = 1 - (-3)^n$. Find</i></p> <p>(a) sebutan pertama / <i>the first term.</i> (b) nisbah sepunya / <i>its common ratio.</i></p> <p style="text-align: right;">[a=4 r=-3]</p>
<p>4. Diberi JG : 2, 6, 18, 54, ...</p> <p>Cari nilai terkecil n supaya hasil tambah n sebutan pertama lebih besar daripada 6000.</p> <p><i>Given GP : 2, 6, 18, 54, ...</i></p> <p><i>Find the smallest n such that the sum of the first n terms is greater than 6000.</i></p> <p style="text-align: right;">[n = 8]</p>	<p>5. Diberi JG : 3, 12, 48, 192, ...</p> <p>Cari nilai terkecil n supaya hasil tambah n sebutan pertama lebih besar daripada 2000.</p> <p><i>Given GP : 3, 12, 48, 192, ...</i></p> <p><i>Find the smallest n such that the sum of the first n terms is greater than 2000.</i></p> <p style="text-align: right;">[n = 6]</p>

6. Sebutan ke-4 suatu jangjang geometri ialah 36. Hasil tambah sebutan ke-4 dan ke-5 ialah 42.

Carikan :

The 4th term of a geometric progression is 36. The sum of the 4th term and the 5th term is 42. Find :

- (a) sebutan pertama dan nisbah sepunya jangjang itu.
the first term and the common ratio of the progression.
- (b) hasil tambah hingga ketakhinggaan jangjang itu.
the sum to infinity of the progression.

[$a = 7776, 9331\frac{1}{5}$]

5.2.3 Menyelesaikan masalah melibatkan jangjang geometri

Solving problems involving geometric progression

1. Sebuah syarikat telekomunikasi berjaya menjual sebanyak 0.5 juta buah telefon pintar pada tahun 2015. Setiap tahun, jualan telefon pintar syarikat tersebut meningkat sebanyak 4%.
A telecommunication company managed to sell 0.5 million smartphones in the year 2015. Every year, the sales of smartphones increases by 4%.

- (a) Cari jumlah telefon pintar yang dijual dari tahun 2015 hingga tahun 2020.
Find the total number of smartphones sold from the year 2015 to the year 2020.
- (b) Jika 33% daripada telefon pintar yang dijual dari tahun 2017 hingga tahun 2020 bersaiz 5 inci dan 14% bersaiz 6 inci, hitung jumlah telefon pintar yang bersaiz 5 inci dan 6 inci.
If 33% of the smartphones sold from the year 2017 to the year 2020 is 5-inched phones and 14% is 6-inched phones, calculate the total number of 5-inched and 6-inched phones?

Penyelesaian / Solutions :

2. Seutas dawai dipotong kepada beberapa bahagian dengan $10x$ cm, $(4x + 20)$ cm dan $(3x - 10)$ cm ialah tiga bahagian yang berturutan bagi suatu jantang geometri.

(a) Cari bahagian terpanjang jika $10x$ ialah sebutan kedua terpanjang.

(b) Jika dawai itu dipotong kepada bilangan bahagian yang tak terhingga, cari panjang maksimum dawai, dalam m.

A wire is cut into a few pieces, in which $10x$ cm, $(4x + 20)$ cm and $(3x - 10)$ cm are the three consecutive pieces of a geometric progression.

(a) Find the longest piece if $10x$ cm is the second longest term.

(b) If the wire is cut into sum to infinity pieces, find the maximum length of the wire, in m.

Penyelesaian / Solutions :

3. Rajah di sebelah menunjukkan corak berbentuk sarang labah-labah.

Lilitan bagi setiap semibulatan adalah mengikut jantang geometri dengan jejari semibulatan terkecil ialah j cm dan setiap jejari berikutnya bertambah sebanyak 40%.

(a) Bentukkan tiga sebutan pertama bagi lilitan semibulatan itu dalam sebutan j .

(b) Cari jumlah panjang lilitan, dalam m, bagi corak sarang labah-labah itu yang mempunyai 15 semibulatan dan jejari 2 cm.

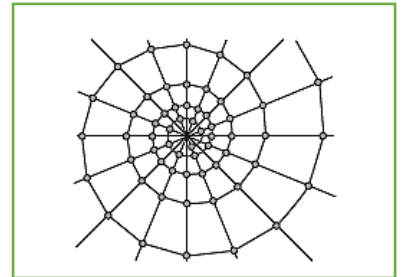

The diagram on the right shows the pattern of a spider web. The perimeter of each of the semicircle follows geometric progression with the smallest radius r cm and each subsequent radius increases 40%.

(a) Form the first three terms for the perimeter of the semicircle in terms of r .

(b) Find the total length of semicircle, in m, if the spider web has 15 semicircles dan each radius 2 cm.

Penyelesaian / Solutions :

Bab 6 – Hukum Linear
Chapter 6 – Linear Law

6.1 Hubungan Linear dan Tak Linear

6.1 Linear and Non-Linear Relations

IMBAS KEMBALI

Bagi graf linear, $Y = mX + c$, X mewakili pemboleh ubah pada paksi mengufuk, Y mewakili pemboleh ubah pada paksi mencancang, m mewakili kecerunan dan c mewakili pintasan-Y.

FLASHBACK

For a linear graph, $Y = mX + c$, X represents the variable on the horizontal axis, Y represents the variable on the vertical axis, m represents the gradient and c represents the Y-intercept.

Nota Penting :
Important Note :

Graf yang membentuk satu garis lurus adalah suatu hubungan linear manakala graf yang tidak membentuk garis lurus adalah suatu hubungan tak linear.

The graph which forms a straight line is a linear relation whereas the graph which does not form a straight line is a non-linear relation.

1. Kenal pasti mana satu ialah graf Linear dan mana satu ialah Graf Tak Linear .
Identify which one is linear graph and which one is non-linear graph.

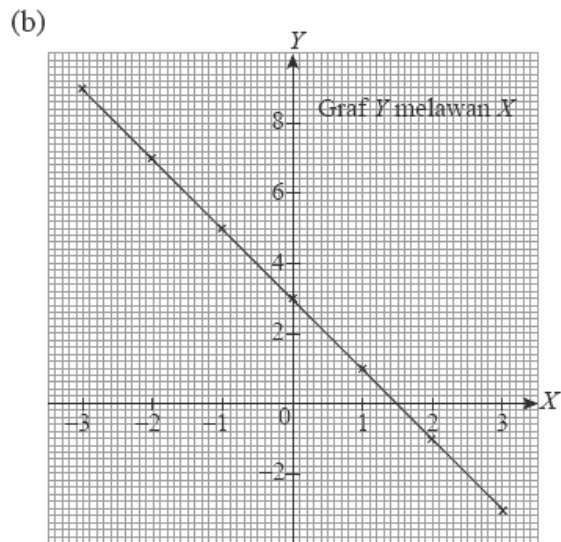
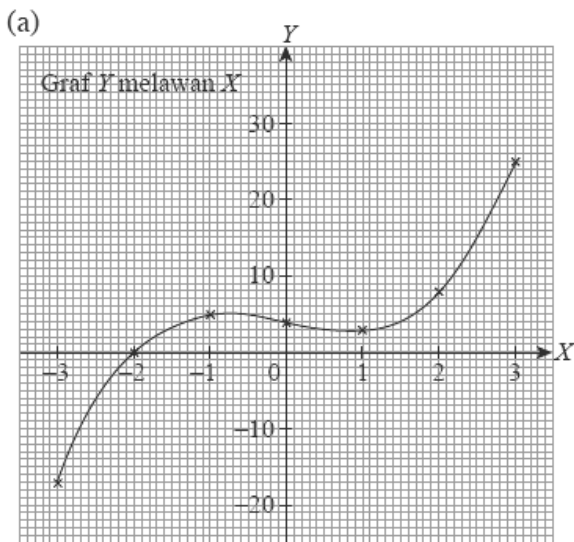

--	--

Cuba Latih Diri 6.1
Try Self Practice 6.1



Melukis garis lurus penyuiaan terbaik bagi graf hubungan linear

Garis lurus penyuiaan terbaik ialah garis lurus yang menyambungkan kebanyakan titik yang diplotkan pada graf. Titik-titik yang tidak terletak pada garis lurus penyuiaan terbaik itu mesti bertaburan secara seimbang di kedua-dua belah garis lurus itu.



Drawing lines of best fit for graphs of linear relations

A line of best fit is a straight line that joins most of the points plotted on the graph. The points which are not on the line of best fit must be distributed evenly on both sides of the straight line.

2. Lukis garis lurus penyuiaan terbaik.

Draw a line of best fit

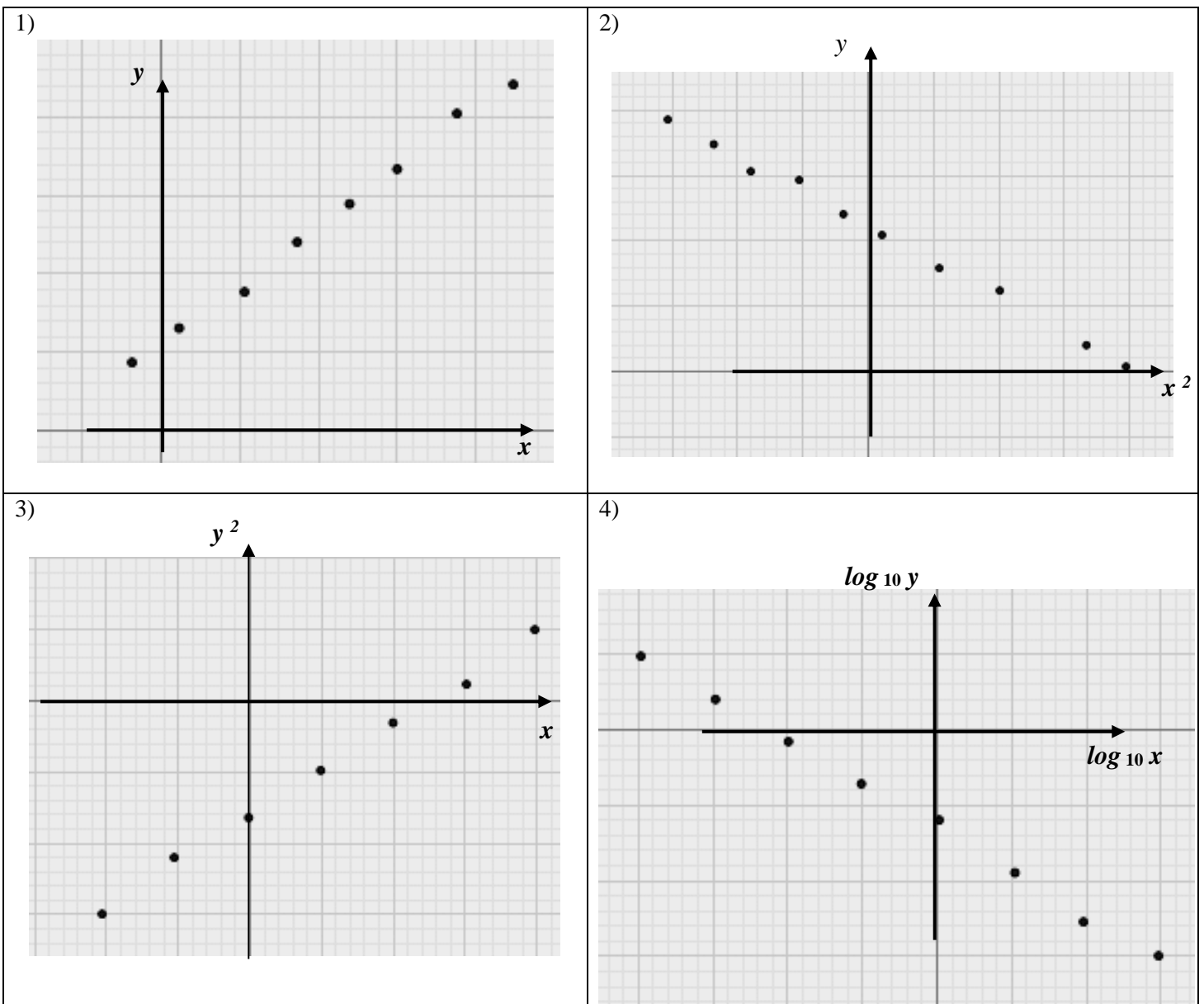

Cuba / Try

Latih Diri 6.2

Self Practice 6.2



Membentuk persamaan bagi garis lurus penyuaiian terbaik

Persamaan garis lurus boleh ditulis dalam bentuk $Y = mX + c$, jika kecerunan, m dan pintasan- Y , c , diketahui atau boleh ditentukan dengan menggunakan sebarang dua titik yang terletak pada garis lurus tersebut.



Forming equations of lines of best fit

The equation of straight lines can be written in the form of $Y = mX + c$, if the gradient, m and Y -intercept, c are known or can be determined by using any two points on the straight line.

3. Daripada setiap **graf linear** berikut, tulis persamaan linear dalam bentuk $Y = mX + C$.

From each following linear graph, write a linear equation in the form of $Y = mX + c$.

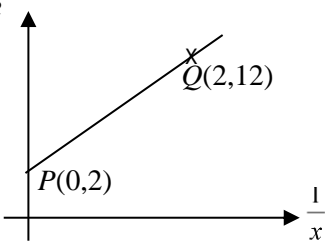
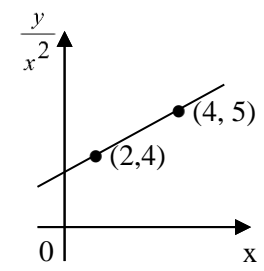
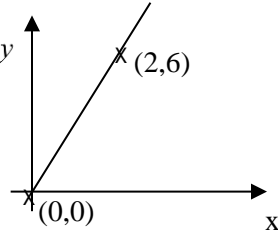
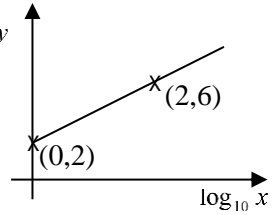
<p>a)</p>  <p style="text-align: right;">$[y^2 = 5\left(\frac{1}{x}\right) + 2]$</p>	<p>b)</p>  <p style="text-align: right;">$[\frac{y}{x^2} = \frac{1}{2}x + 3]$</p>
<p>c)</p>  <p style="text-align: right;">$[\log_{10} y = 3x]$</p>	<p>d)</p>  <p style="text-align: right;">$[\log_{10} y = 2 \log_{10} x + 2]$</p>

4. Berdasarkan graf garis lurus penyuiaan terbaik berikut, ungkapkan y dalam sebutan x.
Based on the graph of line of best fit, express y in the term of x.

<p>a)</p> <p style="text-align: right;">[$y = 4 - \frac{4}{x}$]</p>	<p>b)</p> <p style="text-align: right;">[$y = \frac{3}{x} - \frac{2}{x^2}$]</p>
<p>c)</p> <p style="text-align: right;">[$y = \frac{1}{2}x^3 + 3x^2$]</p>	<p>d)</p> <p style="text-align: right;">[$y = 10^{3x}$]</p>

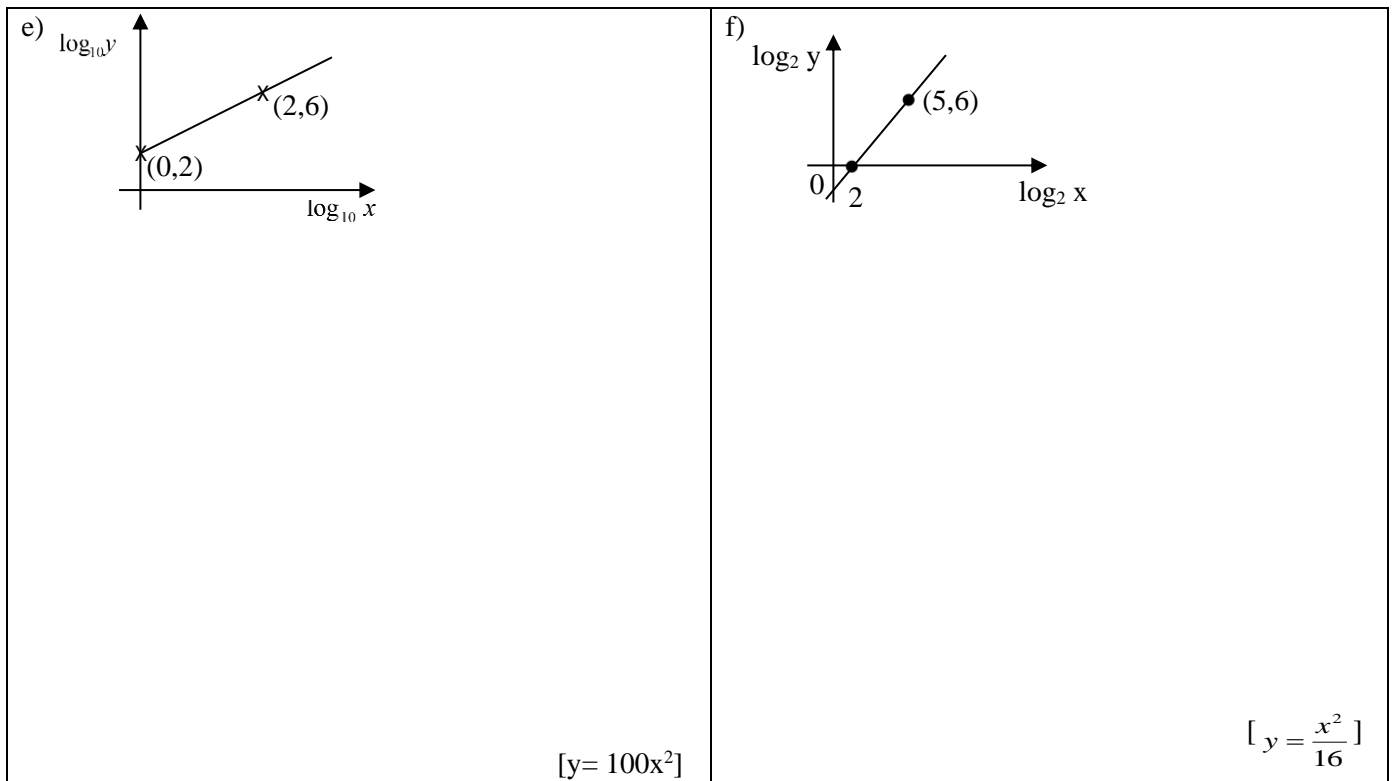

5. Graf garis lurus penyuaiian terbaik dalam rajah di bawah menunjukkan nilai-nilai yang diperoleh daripada suatu eksperimen yang melibatkan dua Pembolehubah , x dan t . Ungkapkan t dalam sebutan x .

The graph of line of best fit in the diagram shows that the obtained values which involved two variables, x and t . Express t in terms of x .

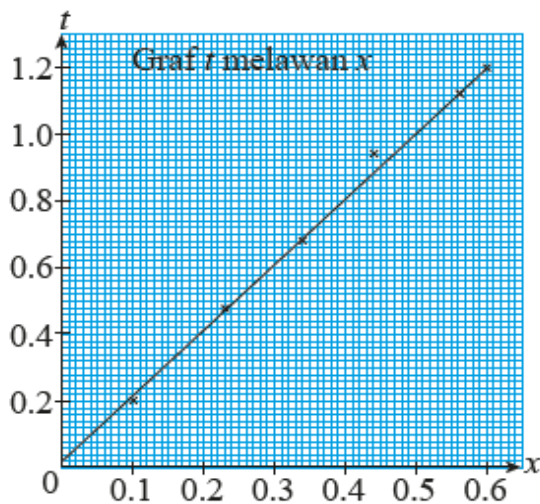

$$[t = \frac{29}{16}x + \frac{1}{50}]$$

Cuba Latih Diri 6.3
Try Self Practice 6.3

Penyelesaian / Solution:



Mentafsir maklumat berdasarkan garis lurus penyuaiian terbaik

Berdasarkan garis lurus penyuaiian terbaik, anda boleh membuat ramalan bagi nilai pemboleh ubah x atau y yang tidak terdapat dalam eksperimen tanpa perlu mengulangi eksperimen tersebut. Jika nilai pemboleh ubah x atau y berada di luar julat titik-titik, anda boleh mencari nilai pemboleh ubah itu dengan memanjangkan garis lurus yang dilukis atau menentukannya dengan membentuk persamaan bagi garis lurus itu.



Interpreting information based on the lines of best fit

Based on the line of best fit, you can predict the values of variables x or y which are not in the experiment without repeating the experiment. If the values of variable x or y are outside the range of points, you can find the value of the variable by extrapolating the drawn straight line or it can be determined by forming the equation of the straight line.

6. Jadual berikut menunjukkan data bagi dua Pemboleh ubah, x dan $\log_{10} y$ yang diperolehi daripada suatu eksperimen bersama dengan grafnya

The following table shows that the data of two variables, x and $\log_{10} y$, which are obtained from an experiment and a graph.

x	0.1	0.3	0.4	0.7	0.8	1.0
$\log_{10} y$	0.40	0.80	1.04	1.60	1.78	2.20

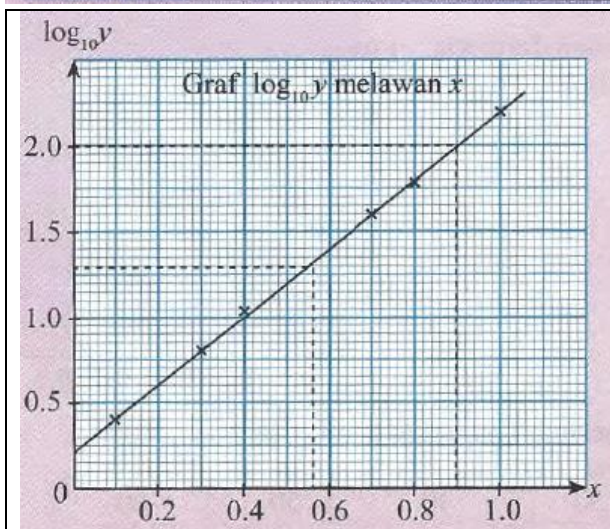

- a) Daripada graph,

- apabila $x = 0.9$, $\log_{10} y = \underline{\hspace{2cm}}$
- apabila $x = 0$, $y = \underline{\hspace{2cm}}$
- apabila $\log_{10} y = 2$, $x = \underline{\hspace{2cm}}$
- apabila $y = 20$, $x = \underline{\hspace{2cm}}$

- b) Cari persamaan garis lurus penyuaiian terbaik itu.

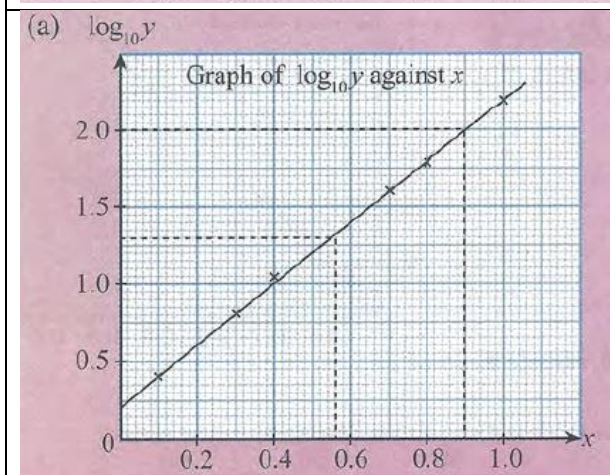

- a) From the graph,

- when $x = 0.9$, $\log_{10} y = \underline{\hspace{2cm}}$
- when $x = 0$, $y = \underline{\hspace{2cm}}$
- when $\log_{10} y = 2$, $x = \underline{\hspace{2cm}}$
- when $y = 20$, $x = \underline{\hspace{2cm}}$

- b) Find the equation of line of best fit.

[Jawapan : (a) 2 ; 1.585 ; 0.9 ; 0.56 (b) $\log_{10} y = 2x + 0.2$]

Cuba Latih Diri 6.4 dan Latihan Intensif 6.1
 Try Self Practice 6.4 and Intensive Practice 6.1

6.2 Hukum Linear dan Hubungan Tak Linear



Mengaplikasikan hukum linear kepada hubungan tak linear

Dengan penggunaan hukum linear, kebanyakan hubungan tak linear boleh ditukarkan kepada hubungan linear supaya satu graf garis lurus dapat dilukis. Daripada graf garis lurus, maklumat dapat diperoleh dengan lebih mudah berbanding graf lengkung.

Persamaan tak linear $y = ax + \frac{b}{x}$, dengan keadaan a dan b ialah pemalar boleh ditukar kepada bentuk persamaan linear $Y = mX + c$ dengan dua kaedah.

6.2 Linear Law and Non-Linear Relations



Applying linear law to non-linear relations

By using linear law, most of the non-linear relations can be converted to linear relations so that a straight line can be drawn. It is easier to obtain information from the straight line graphs than from the curves.

The non-linear equation $y = ax + \frac{b}{x}$, such that a and b are constants can be converted to linear equation form $Y = mX + c$ by using two methods.

7. Tukarkan setiap yang berikut kepada persamaan dalam bentuk linear. Seterusnya nyatakan kecerunan dan pintasan-y

Convert each of the following to an equation in the linear form. Hence, state the gradient and its y-intercept

Persamaan Tak Linear <i>Non-Linear Equation</i>	Bentuk linear $Y = mX + C$ <i>Linear Equation Form $Y = mX + c$</i>	Y	X	m	c
a) $y = ax^2 + bx$		$\frac{y}{x}$	x		
b) $y = ax^3 + bx^2$		$\frac{y}{x^2}$	x		

c) $y = \frac{a}{x} + b$		y	$\frac{1}{x}$		
d) $y = \frac{a}{x} + bx$		xy	x^2		
e) $xy = \frac{a}{x} + bx$		y	$\frac{1}{x^2}$		
f) $x + by = axy$		$\frac{1}{y}$	$\frac{1}{x}$		
g) $y = \frac{5}{x} - 3x$		xy	x^2		
h) $y = \frac{a(b-x)}{x^2}$		xy	$\frac{1}{x}$		
i) $y = ab^x$		$\log_{10} y$	x		
j) $y = ax^b$		$\log_{10} y$	$\log_{10} x$		

k) $y = a^2 x^b$		$\log_{10} y$	$\log_{10} x$		
1) $y = pq^{x+1}$		$\log_{10} y$	$\log_{10} q$		

8. Selesaikan masalah yang berikut

Solve the following problems

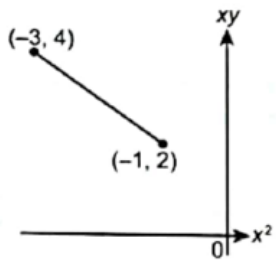
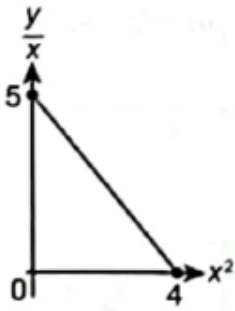
<div style="text-align: center; margin-bottom: 20px;">  </div> <p>a) Rajah di atas menunjukkan graf garis lurus xy melawan x^2. Diberi $\frac{y}{x} = \frac{p}{x^2} - \frac{q}{x}$, cari nilai p dan q.</p> <p><i>The diagram above shows a straight line graph xy against x^2. Given that $\frac{y}{x} = \frac{p}{x^2} - \frac{q}{x}$, find the value of p and q.</i></p> <div style="text-align: right; margin-top: 20px;"> $[p=1 ; q=1]$ </div>	<div style="text-align: center; margin-bottom: 20px;">  </div> <p>b) Rajah di atas menunjukkan graf garis lurus $\frac{y}{x}$ melawan x^2. Diberi $\frac{y}{x^2} = \frac{p}{x} - qx$, cari nilai p dan q.</p> <p><i>The diagram above shows a straight line $\frac{y}{x}$ against x^2. Given that $\frac{y}{x^2} = \frac{p}{x} - qx$, find the value of p and q.</i></p> <div style="text-align: right; margin-top: 20px;"> $[p = 5 ; q = \frac{5}{4}]$ </div>
--------------------------------------------------------------------------------------------------------------------------------------------------------------------------------------------------------------------------------------------------------------------------------------------------------------------------------------------------------------------------------------------------------------------------------------------------------------------------------------------------------------------------------------------------------------------------------------------------------------------------------------------------------------------------------	-------------------------------------------------------------------------------------------------------------------------------------------------------------------------------------------------------------------------------------------------------------------------------------------------------------------------------------------------------------------------------------------------------------------------------------------------------------------------------------------------------------------------------------------------------------------------------------------------------------------------------------------------------------------------------------------

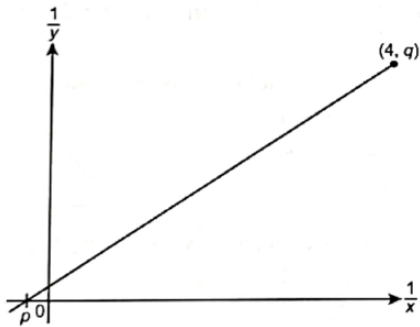

- c) Pembolehubah x dan y dihubungkan oleh persamaan $y = \frac{2x}{x+4}$, cari nilai p dan q .
Variables x and y are related by the equation $y = \frac{2x}{x+4}$, find the value of p and q .

[$p = -0.25$; $q = 8.5$]

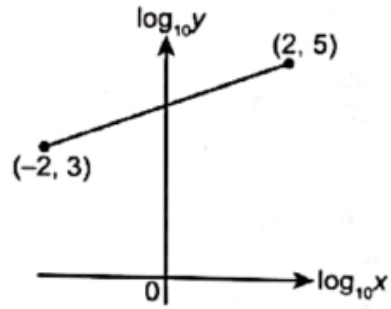

- d) Pembolehubah x dan y dihubungkan oleh persamaan $y = ax^b$, cari nilai a dan b .
Variables x and y are related by the equation $y = ax^b$, find the value of a and b .

[$a = 10000$, $b = 0.5$]

Cuba Latih Diri 6.5 dan Latihan Intensif 6.2
Try Self Practice 6.5 and Intensive Practice 6.2

6.3 Aplikasi Hukum Linear



Menyelesaikan masalah melibatkan hukum linear

6.3 Application of Linear Law



Solving problems involving linear law

Contoh:

Satu eksperimen telah dijalankan untuk mengetahui kesan tumbesaran bagi sejenis tumbuhan terhadap kepekatan suatu hormon. Bacaan nilai daripada eksperimen tersebut telah dicatatkan dalam jadual di bawah. Tumbesaran tumbuhan itu dan kepekatan hormon dihubungkan oleh persamaan $P = 180 + rK - sK^2$, dengan r dan s ialah pemalar.

Kepekatan hormon per juta (K)	1	3	4	6	8	10
% tumbesaran tumbuhan (P)	181	179.7	178	168	157	140

- (a) Plot graf $\frac{P-180}{K}$ melawan K , dengan menggunakan skala 2 cm kepada 2 unit pada paksi-X dan 2 cm kepada 1 unit pada paksi-Y. Seterusnya, lukis garis lurus penyuaian terbaik.
- (b) Daripada graf, hitung nilai r dan nilai s .

Penyelesaian

1. Memahami masalah

- ◆ Kenal pasti pemboleh ubah untuk menentukan paksi-X dan paksi-Y.
- ◆ Plot graf dengan menggunakan skala yang diberikan.
- ◆ Berdasarkan graf, cari nilai r dan nilai s .

2. Merancang strategi

- (a) Tukarkan persamaan tak linear kepada bentuk linear dan bandingkan dengan bentuk $Y = mX + c$, dengan keadaan m ialah kecerunan dan c ialah pintasan paksi-Y.
- (b) Bina satu jadual baharu menggunakan pemboleh ubah itu.
- (c) Plot graf dengan menggunakan nilai-nilai pada jadual baharu.
- (d) Cari pintasan-Y dan kecerunan dengan merujuk kepada graf. Seterusnya, bandingkan dengan persamaan $Y = mX + c$.

3. Melaksanakan strategi

(a)
$$P = 180 + rK - sK^2$$

$$P - 180 = rK - sK^2$$

$$\frac{P - 180}{K} = \frac{rK}{K} - \frac{sK^2}{K}$$

$$\frac{P - 180}{K} = r - sK$$

$$\frac{P - 180}{K} = -sK + r$$

Melalui perbandingan, $Y = \frac{P - 180}{K}$, $X = K$, $m = -s$ dan $c = r$.

K	1	3	4	6	8	10
$\frac{P - 180}{K}$	1.00	-0.10	-0.50	-2.00	-2.88	-4.00

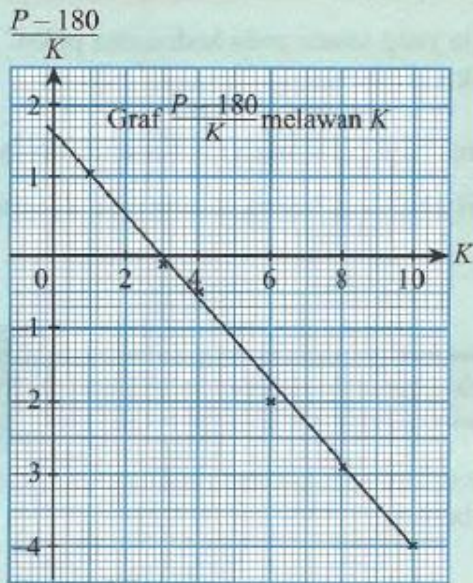

(b) Pintasannya $Y = 1.6$
 $r = 1.6$

Kecerunan, $-s = \frac{-4 - 1.6}{10 - 0}$
 $-s = -0.56$
 $s = 0.56$

4. Membuat refleksi

Apabila $K = 1$,
 $P = 180 + rK - sK^2$
 $= 180 + (1.6)(1) - (0.56)(1)^2$
 $= 181.04$
 ≈ 181

Apabila $K = 3$,
 $P = 180 + rK - sK^2$
 $= 180 + (1.6)(3) - (0.56)(3)^2$
 $= 179.76$
 ≈ 179.7

Example :

An experiment is carried out to study the effect of the growth of a plant on the concentration of a hormone. The readings from the experiment are recorded in the table below. The growth of the plant and the concentration of hormone are related by the equation $P = 180 + rK - sK^2$, such that r and s are constants.

Concentration of hormone per million (K)	1	3	4	6	8	10
% growth of plant (P)	181	179.7	178	168	157	140

- (a) Plot the graph of $\frac{P-180}{K}$ against K , by using a scale of 2 cm to 2 units on the X -axis and 2 cm to 1 unit on the Y -axis. Hence, draw the line of best fit.
 (b) From the graph, calculate the value of r and s .

Solution

1. Understanding the problem

- ◆ Identify the variables to determine the X -axis and Y -axis.
- ◆ Plot the graph by using the scales given.
- ◆ Based on the graph, find the value of r and s .

2. Planning the strategy

- Convert the non-linear equation to the linear form and compare with the form $Y = mX + c$, such that m is the gradient and c is the Y -intercept.
- Construct a new table using the new variables.
- Plot the graph by using the values in the new table.
- Find the y -intercept and gradient by referring to the graph. Hence, compare with the equation $Y = mX + c$.

3. Implementing the strategy

$$(a) \quad P = 180 + rK - sK^2$$

$$P - 180 = rK - sK^2$$

$$\frac{P - 180}{K} = \frac{rK}{K} - \frac{sK^2}{K}$$

$$\frac{P - 180}{K} = r - sK$$

$$\frac{P - 180}{K} = -sK + r$$

Through comparison, $Y = \frac{P - 180}{K}$, $X = K$, $m = -s$ and $c = r$.

K	1	3	4	6	8	10
$\frac{P - 180}{K}$	1.00	-0.10	-0.50	-2.00	-2.88	-4.00

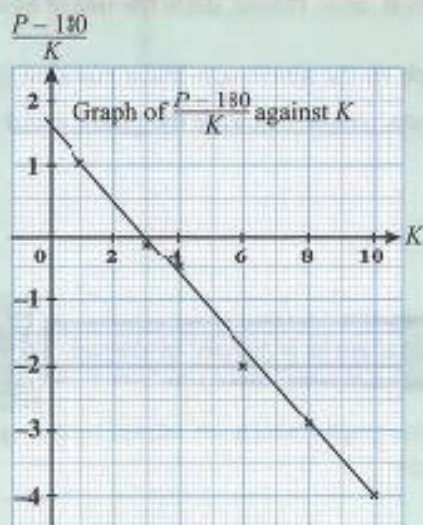

$$(b) \quad Y\text{-intercept} = 1.6$$

$$r = 1.6$$

$$\text{Gradient, } -s = \frac{-4 - 1.6}{10 - 0}$$

$$-s = -0.56$$

$$s = 0.56$$

4. Making a conclusion

When $K = 1$,

$$P = 180 + rK - sK^2$$

$$= 180 + (1.6)(1) - (0.56)(1)^2$$

$$= 181.04$$

$$\approx 181$$

When $K = 3$,

$$P = 180 + rK - sK^2$$

$$= 180 + (1.6)(3) - (0.56)(3)^2$$

$$= 179.76$$

$$\approx 179.7$$

9. Selesaikan masalah yang berikut :

Solve the following problems

a) Jadual 1 menunjukkan nilai-nilai bagi bagi 2 pembolehubah , x dan y yang diperoleh daripada $y = px^q$, dengan keadaan p dan q ialah pemalar.

Table 1 shows the values of two variables, x and y , obtained from an experiment. It is known that the variables x and y are related by the equation $y = px^q$, where p and q are constants.

x	10	50	635	1585	6300
y	2.1	2.25	3.6	4.1	4.8

Jadual 1 / Table 1

- (i) Berdasarkan Jadual 1 di atas, bina satu jadual baru bagi nilai-nilai $\log_{10} y$ dan $\log_{10} x$
Based on the above Table 1, construct a new table for the values of $\log_{10} y$ and $\log_{10} x$
- (ii) Plot $\log_{10} y$ melawan $\log_{10} x$ dengan menggunakan skala 2 cm kepada 0.5 unit pada paksi mengufuk dan 2cm kepada 0.1 unit pada paksi mencancang. Seterusnya, lukis garis penyesuaian terbaik.
Plot $\log_{10} y$ against $\log_{10} x$ using a scale of 2 cm to 0.5 unit on the horizontal axis and 2cm to 0.1 unit on the vertical axis. Hence, draw a line of best fit.
- (iii) Gunakan graf di (ii) untuk mencari nilai
Use the graph in (ii) to find the value of
- (a) p
(b) q
(c) x apabila $y = 2.8$
 x when $y = 2.8$

[$p=1.55$; $q=0.13$; $x=100$]

b) **Klon SPM 2018**

Jadual 2 menunjukkan nilai-nilai bagi dua pembolehubah , x dan y, yang diperoleh daripada suatu eksperimen. Satu garis lurus diperoleh apabila graf $\frac{y^2}{x}$ melawan $\frac{1}{x}$ diplotkan

Table 2 shows the values of two variables, x and y, obtained from an experiment. A straight line will be obtained when a graph of $\frac{y^2}{x}$ against $\frac{1}{x}$, is plotted.

x	1.25	1.43	2.00	2.50	4.00	5.00
y	4.47	4.38	4.18	3.87	2.83	2.24

Jadual 2 / Table 2

(i) Berdasarkan Jadual 2 di atas, bina satu jadual baru bagi nilai-nilai $\frac{y^2}{x}$ dan $\frac{1}{x}$.

Based on Table 2, construct a new table for the values of $\frac{y^2}{x}$ and $\frac{1}{x}$.

(ii) Plotkan $\frac{y^2}{x}$ melawan $\frac{1}{x}$ diplotkan dengan menggunakan skala 2 cm kepada 0.1 unit pada paksi $\frac{1}{x}$ dan 2 cm kepada 2 unit pada paksi $\frac{y^2}{x}$. Seterusnya, lukis garis lurus penyesuaian terbaik.

Plot $\frac{y^2}{x}$ against $\frac{1}{x}$ using a scale of 2 cm to 0.1 unit on the $\frac{1}{x}$ axis and 2 cm to 2 unit on the $\frac{y^2}{x}$ axis. Hence, draw the line of best fit.

(iii) Menggunakan graf di (ii)

Using the graph in (b)

(a) Cari nilai y apabila x = 2.7

Find the value of y when x=2.7

(b) Ungkapkan y dalam sebutan x.

Express y in terms of x.

$$[y=3.75, y=\sqrt{25-4x}]$$

c) **Klon SPM 2019**

Jadual 3 menunjukkan nilai-nilai bagi dua pembolehubah , x dan y yang diperolehi daripada suatu eksperimen. Pembolehubah x dan y dihubungkan oleh persamaan $y = \frac{a}{b\sqrt{x}}$ dengan keadaan a dan b ialah pemalar.

Table 3 shows the values of two variables, x and y , obtained from an experiment. The variables x and y are related by the equation $y = \frac{a}{b\sqrt{x}}$ where a and b are constants.

x	0.34	0.43	0.55	0.85	1.08	1.42
y	47.68	25.12	12.58	4.17	2.51	1.38

Jadual 3 / Table 3

- (i) Berdasarkan Jadual 3, bina satu jadual baru bagi nilai-nilai $\log_{10} x$ dan $\log_{10} y$.
Based on Table 3, construct a table for the values of $\log_{10} x$ dan $\log_{10} y$.
- (ii) Plot $\log_{10} y$ melawan $\log_{10} x$, menggunakan skala 2 cm kepada 0.1 unit pada paksi X dan 2 cm kepada 0.2 unit pada paksi Y. Seterusnya, lukis garis lurus penyesuaian terbaik.
Plot $\log_{10} y$ against $\log_{10} x$, using a scale of 2 cm to 0.1 unit on the X axis and 2 cm to 0.2 unit on the Y axis. Hence, draw the line of best fit.
- (iii) Menggunakan graf di (ii), cari nilai
Using the graph in (ii), find the value of
(a) a
(b) b

[$a=2.754$, $b=0.3772$]

1. Klon SPM2015

Rajah menunjukkan graf garis lurus yang diperoleh dengan memplot $(y-x)$ melawan x^2 .

Diagram shows the straight line graph obtained by plotting $(y-x)$ against x^2 .

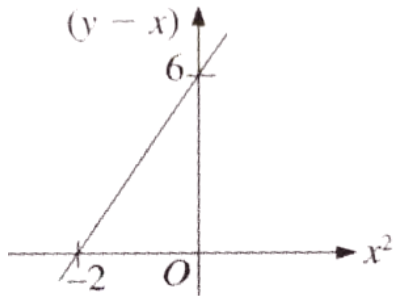

Ungkapkan y dalam sebutan x .

Express y in terms of x .

[$y=3x^2+x+6$]

2. Klon SPM2016

Pembolehubah x dan y dihubungkan oleh persamaan $y = 2x^2 - \frac{q}{x^2}$, dengan keadaan q ialah pemalar. Suatu garis lurus diperoleh dengan meplotkan xy melawan x^3 seperti rajah.

The variables x and y are related by the equation $y = 2x^2 - \frac{q}{x^2}$, where q is a constant. A straight line is obtained by plotting against x^3 , as shown in diagram.

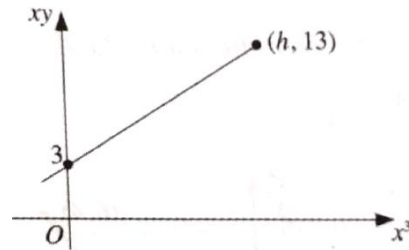

Cari nilai h dan q .

Find the value of h and q .

[$h=5 ; q=-3$]

3. **Klon SPM 2017**

Pembolehubah x dan y dihubungkan oleh persamaan $y = x + \frac{r}{x^2}$, dengan keadaan r ialah pemalar. Rajah di bawah menunjukkan graf garis lurus yang diperoleh dengan memplotkan $(y-x)$ melawan $\frac{1}{x^2}$.

Ungkapkan h dalam sebutan p dan r .

The variables x and y are related by the equation $y = x + \frac{r}{x^2}$, where r is a constant. Diagram below shows a straight line graph obtained by plotting $(y-x)$ against $\frac{1}{x^2}$.

Express h in terms of p and r .

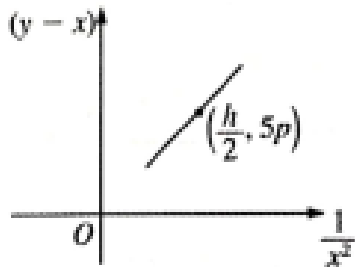

$$\left[h = \frac{10p}{r} \right]$$

4. **Klon SPM2018**

Rajah di bawah menunjukkan graf garis lurus $\frac{x^2}{y}$ melawan $\frac{1}{x}$. Berdasarkan rajah ini, ungkapkan y dalam sebutan x .

Diagram below shows the graph of a straight line $\frac{x^2}{y}$ against $\frac{1}{x}$. Based on diagram, express y in terms of x .

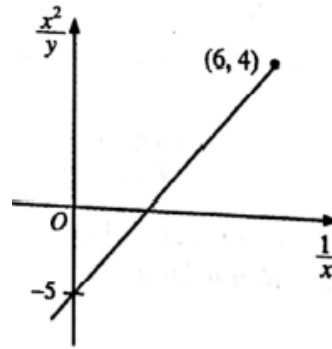

$$\left[y = \frac{2x^3}{3-10x} \right]$$

5. **Klon SPM 2015**

Jadual 4 menunjukkan nilai-nilai bagi dua pembolehubah, x dan y , yang diperolehi daripada suatu eksperimen. Pembolehubah x dan y dihubungkan oleh persamaan $nx = py + xy$, dengan keadaan n dan p ialah pemalar.

Table 4 shows the values of two variables, x and y , obtained from an experiment. Variables x and y are related by the equation $nx = py + xy$, where n and p are constants.

x	1.5	2.0	3.0	4.0	5.0	6.0
y	2.020	0.770	0.465	0.385	0.351	0.339

Jadual 4 / Table 4

- (a) Berdasarkan Jadual 4, bina satu jadual bagi nilai-nilai $\frac{1}{y}$ dan $\frac{1}{x}$.

Based on Table 4, construct a table for the values of $\frac{1}{y}$ and $\frac{1}{x}$.

- (b) Plot $\frac{1}{y}$ melawan $\frac{1}{x}$, dengan menggunakan skala 2 cm kepada 0.1 unit pada paksi $\frac{1}{x}$ dan 2cm kepada 0.5 unit pada paksi $\frac{1}{y}$. Seterusnya, lukis garis penyesuaian terbaik.

Plot $\frac{1}{y}$ against $\frac{1}{x}$, using a scale of 2 cm to 0.1 unit on $\frac{1}{x}$ axis and 2 cm to 0.5 unit on $\frac{1}{y}$ axis. Hence, draw the line of best fit.

- (c) Menggunakan graf di (b), cari nilai

Using the graph in (b), find the value of

- (i) n
 (ii) p

[$n = 0.26$, $p = -1.3$]

6. Klon SPM 2016

Jadual 5 menunjukkan nilai-nilai bagi dua pembolehubah, x dan y , yang diperoleh daripada suatu eksperimen. Pembolehubah x dan y dihubungkan oleh persamaan $y = 2px + \frac{q}{5x}$, dengan keadaan p dan q ialah pemalar.

Table 5 shows the values of two variables, x and y , obtained from an experiment. Variables x and y are related by the equation $y = 2px + \frac{q}{5x}$, where p and q are constants.

x	1	2	3	4	5	6
y	3.10	2.30	2.33	2.35	2.72	3.00

Jadual 5 / Table 5

(a) Berdasarkan Jadual 5, bina satu jadual bagi nilai-nilai x^2 dan xy

Based on Table 5, construct a table for the values of x^2 and xy

(b) Plot xy melawan x^2 , menggunakan skala 2 cm kepada 5 unit pada paksi x^2 dan 2 cm kepada 2 unit pada paksi xy . Seterusnya, lukis garis lurus penyesuaian terbaik.

Plot xy against x^2 , using a scale of 2 cm to 5 unit on the x^2 axis and 2 cm to 2 unit on the xy axis. Hence, draw the line of best fit.

(c) Menggunakan graf di (b), cari nilai

Using the graph in (b), find the value of

- (i) p
- (ii) q

7. **Klon SPM 2017**

Jadual 5 menunjukkan nilai-nilai bagi dua pembolehubah, x dan y , yang diperoleh daripada suatu eksperimen. Pembolehubah x dan y dihubungkan oleh persamaan $y - \sqrt{h} = \frac{hk}{x}$, dengan keadaan h dan k ialah pemalar.

Table 5 shows the values of two variables, x and y , obtained from an experiment. Variables x and y are related by the equation $y - \sqrt{h} = \frac{hk}{x}$, where h and k are constants.

x	1.5	2.0	3.5	4.5	5.0	6.0
y	4.5	2.25	5.5	6.3	6.34	

- (a) Plot xy melawan x , menggunakan skala 2 cm kepada 1 unit pada paksi x dan 2 cm kepada 5 unit pada paksi xy . Seterusnya, lukis garis lurus penyesuaian terbaik.

Plot xy against x , using a scale of 2 cm to 1 unit on the x axis and 2 cm to 5 units on the xy axis. Hence, draw the line of best fit.

- (b) Menggunakan graf di (a), cari

Using the graph in (a), find

- (i) nilai h dan k
the value of h and k

- (ii) nilai y yang betul jika satu daripada nilai-nilai y yang telah tersalah catat semasa eksperimen.
the correct value of y if one of the value of y has been wrongly recorded during the experiment.

BAB 7 GEOMETRI KOORDINAT
CHAPTER 7 COORDINATE GEOMETRY

7.3 Luas Poligon

Areas of polygons

7.3.1 Menerbitkan rumus luas segi tiga

Deriving formula of area of triangles

$$\begin{aligned}
 \text{Luas } \triangle ABC &= \text{luas } \triangle ACD + \text{luas trapezium } BCDE - \text{luas } \triangle ABE \\
 &= \left(\frac{1}{2} \times AD \times CD\right) + \left(\frac{1}{2} \times DE \times (BE + CD)\right) - \left(\frac{1}{2} \times AE \times BE\right) \\
 &= \frac{1}{2}(x_3 - x_1)(y_3 - y_1) + \frac{1}{2}(x_2 - x_3)[(y_2 - y_1) + (y_3 - y_1)] \\
 &\quad - \frac{1}{2}(x_2 - x_1)(y_2 - y_1) \\
 &= \frac{1}{2}(x_3y_3 - x_3y_1 - x_1y_3 + x_1y_1 + x_2y_2 - x_2y_1 + x_2y_3 - x_2y_1 - x_3y_2 \\
 &\quad + x_3y_1 - x_3y_3 + x_3y_1 - x_2y_2 + x_2y_1 + x_1y_2 - x_1y_1) \\
 &= \frac{1}{2}(x_1y_2 + x_2y_3 + x_3y_1 - x_2y_1 - x_3y_2 - x_1y_3)
 \end{aligned}$$

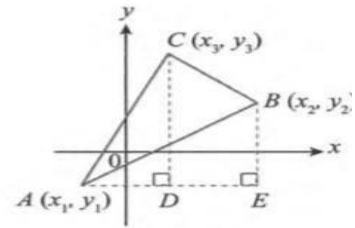

Rajah 7.2

$$\begin{aligned}
 \text{Luas } \triangle ABC &= \frac{1}{2} \begin{vmatrix} x_1 & x_2 & x_3 & x_1 \\ y_1 & y_2 & y_3 & y_1 \end{vmatrix} \\
 &= \frac{1}{2} |x_1y_2 + x_2y_3 + x_3y_1 - x_2y_1 - x_3y_2 - x_1y_3| \\
 &= \frac{1}{2} |(x_1y_2 + x_2y_3 + x_3y_1) - (x_2y_1 + x_3y_2 + x_1y_3)|
 \end{aligned}$$

7.3.2 Menentukan luas segi tiga dengan menggunakan rumus

Determining the area of triangles by using the formula

Contoh:

Example:

Cari luas $\triangle ABC$ dengan bucu-bucunya ialah $A(-4, -6)$, $B(5, 3)$ dan $C(2, 8)$.

Find the area of $\triangle ABC$ with vertices $A(-4, -6)$, $B(5, 3)$ and $C(2, 8)$.

Penyelesaian:

Solution:

Jika koordinat disusun mengikut tertib arah lawan jam,
luas $\triangle ABC$

$$\begin{aligned}
 &= \frac{1}{2} \begin{vmatrix} -4 & 5 & 2 & -4 \\ -6 & 3 & 8 & -6 \end{vmatrix} \\
 &= \frac{1}{2} |(-12 + 40 - 12) - (-30 + 6 - 32)| \\
 &= \frac{1}{2} |72| \\
 &= 36 \text{ unit}^2
 \end{aligned}$$

Jika koordinat disusun mengikut tertib arah jam,
luas $\triangle ABC = \frac{1}{2} \begin{vmatrix} -4 & 2 & 5 & -4 \\ -6 & 8 & 3 & -6 \end{vmatrix}$

$$\begin{aligned}
 &= \frac{1}{2} |(-32 + 6 - 30) - (-12 + 40 - 12)| \\
 &= \frac{1}{2} |-72| \leftarrow \text{Ambil nilai mutlak} \\
 &= \frac{1}{2} (72) \\
 &= 36 \text{ unit}^2
 \end{aligned}$$

Contoh:

Example:

Koordinat bagi bucu-bucu sebuah segi tiga ABC ialah $A(8, 5)$, $B(-2, -3)$ dan $C(k, -1)$. Cari nilai-nilai yang mungkin bagi k jika luas segi tiga ABC ialah 18 unit^2 .

The coordinates of the vertices of a triangle ABC are $A(8, 5)$, $B(-2, -3)$ and $C(k, -1)$. if the area of triangle ABC is 18 units^2 , find the possible values of k .

Penyelesaian:

Solution:

Oleh sebab urutan bucu bagi segi tiga ABC tidak diketahui, luasnya mungkin bernilai positif atau negatif.

$$\text{Luas } \Delta ABC = \frac{1}{2} \begin{vmatrix} 8 & -2 & k & 8 \\ 5 & -3 & -1 & 5 \end{vmatrix}$$

$$18 = \frac{1}{2} |(-24 + 2 + 5k) - (-10 - 3k - 8)|$$

$$\pm 18 = \frac{1}{2}(8k - 4)$$

$$\frac{1}{2}(8k - 4) = -18 \quad \text{atau} \quad \frac{1}{2}(8k - 4) = 18$$

$$8k - 4 = -36$$

$$8k = -32$$

$$k = -4$$

$$8k - 4 = 36$$

$$8k = 40$$

$$k = 5$$

Maka, nilai-nilai yang mungkin bagi k ialah -4 dan 5 .

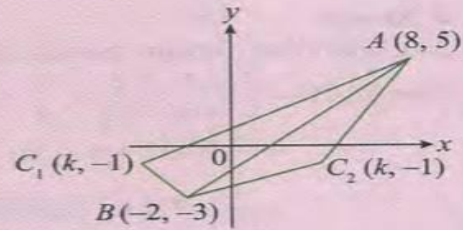

Latihan Kendiri/ Self Practice:

1. Cari luas segi tiga dengan bucu-bucu yang diberi seperti berikut.

Find the area of the triangles with the following vertices given.

(a) $(5,10)$, $(2,1)$, $(8,3)$

(b) $(3,1)$, $(6,4)$, $(-4,2)$

(c) $(-4, -3)$, $(5,1)$, $(2,6)$

Jawapan/Answer: $[24 \text{ unit}^2]$

Jawapan/Answer: $[12 \text{ unit}^2]$

Jawapan/Answer: $[28\frac{1}{2} \text{ unit}^2]$

2. Bucu-bucu P dan Q masing-masing ialah $(3,4)$ dan $(1,-2)$, dan bucu R terletak pada paksi-x. Cari koordinat R yang mungkin, dengan keadaan luas ΔPQR ialah 10 unit^2 .

Vertices P and Q are $(3,4)$ and $(1, -2)$, respectively, and vertex R is on the x-axis. Find the coordinates of R such that area of ΔPQR is 10 units^2 .

Jawapan/Answer: $[(5,0), (-\frac{5}{3}, 0)]$

3. Tunjukkan bahawa titik-titik $(8,4)$, $(2,1)$ dan $(-2, -1)$ adalah segaris.
Show that points $(8,4)$, $(2,1)$ and $(-2, -1)$ are collinear.

4. Titik $E(-2, -1)$, $F(2, P)$ dan $G(10,5)$ adalah segaris. Cari nilai p .
Points $E(-2, -1)$, $F(2, P)$ and $G(10,5)$ are collinear. Find the value of p .

Jawapan/Answer: [$p = 1$]

5. Bucu-bucu dan luas bagi ΔABC diberi seperti berikut, Cari nilai-nilai yang mungkin bagi k .
The vertices and area of ΔABC are given below. Find the possible values of k .

- (a) $A(-4, -1)$, $B(5,3)$, $C(-1, K)$;
luas $\Delta ABC = 15 \text{ unit}^2$.

Jawapan/Answer: [$-3, \frac{11}{3}$]

- (b) $A(5, k)$, $B(3,7)$, $C(1,3)$;
luas $\Delta ABC = 10 \text{ unit}^2$.

Jawapan/Answer: [$1,21$]

- (c) $A(1, -2)$, $B(k, 6)$, $C(1,2)$;
luas $\Delta ABC = 12 \text{ unit}^2$.

Jawapan/Answer: [$-5,7$]

- (d) $A(3,0)$, $B(4, k)$, $C(1,4)$;
luas $\Delta ABC = 5 \text{ unit}^2$.

Jawapan/Answer: [$-7,3$]

7.3.3 Menentukan luas sisi empat dengan menggunakan rumus
Determining the area of quadrilaterals by using the formula

$$\begin{aligned} \text{Luas sisi empat } ABCD &= \text{luas } \triangle ABC + \text{luas } \triangle ACD \\ &= \frac{1}{2} \begin{vmatrix} x_1 & x_2 & x_3 & x_1 \\ y_1 & y_2 & y_3 & y_1 \end{vmatrix} + \frac{1}{2} \begin{vmatrix} x_1 & x_3 & x_4 & x_1 \\ y_1 & y_3 & y_4 & y_1 \end{vmatrix} \\ &= \frac{1}{2} [(x_1y_2 + x_2y_3 + x_3y_1) - (x_2y_1 + x_3y_2 + x_4y_3)] \\ &\quad + \frac{1}{2} [(x_1y_3 + x_3y_4 + x_4y_1) - (x_2y_1 + x_2y_3 + x_1y_4)] \\ &= \frac{1}{2} [(x_1y_2 + x_2y_3 + x_3y_4 + x_4y_1) - (x_2y_1 + x_3y_2 + x_4y_3 + x_1y_4)] \\ &= \frac{1}{2} \begin{vmatrix} x_1 & x_2 & x_3 & x_4 & x_1 \\ y_1 & y_2 & y_3 & y_4 & y_1 \end{vmatrix} \end{aligned}$$

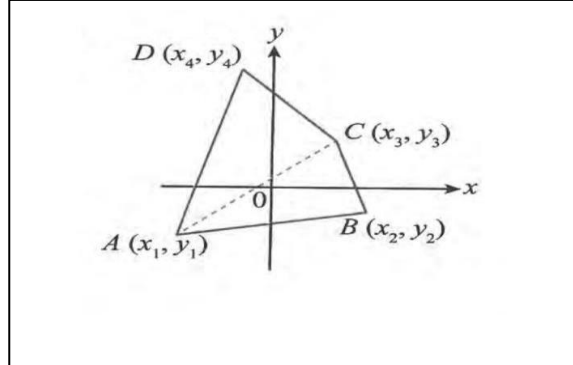

$$\begin{aligned} \text{Luas sisi empat } ABCD &= \frac{1}{2} \begin{vmatrix} x_1 & x_2 & x_3 & x_4 & x_1 \\ y_1 & y_2 & y_3 & y_4 & y_1 \end{vmatrix} \\ &= \frac{1}{2} |(x_1y_2 + x_2y_3 + x_3y_4 + x_4y_1) - (x_2y_1 + x_3y_2 + x_4y_3 + x_1y_4)| \end{aligned}$$

Contoh:

Example:

Cari luas sisi empat PQRS dengan bucu-bucu P(3,5), Q(-1,3), R(2,-3) dan S(4,1).

Find the area of quadrilateral PQRS with vertices P(3,5), Q(-1,3), R(2,-3) and S(4,1).

Penyelesaian:

Solution:

Susun bucu-bucu mengikut tertib:

$$\begin{aligned} \text{Luas sisi empat } PQRS &= \frac{1}{2} \begin{vmatrix} 3 & -1 & 2 & 4 & 3 \\ 5 & 3 & -3 & 1 & 5 \end{vmatrix} \\ &= \frac{1}{2} |(9 + 3 + 2 + 20) - (-5 + 6 - 12 + 3)| \\ &= \frac{1}{2} |42| \\ &= 21 \text{ unit}^2 \end{aligned}$$

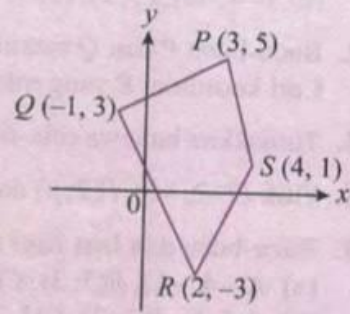

Latihan Kendiri/ Self Practice:

1. Cari luas sisi empat dengan bucu-bucu yang diberi seperti berikut:

Find the equation of the tangent and normal to the following curves at the given points.

(a) (1,7), (-5,6), (-2, -4) dan (2, -3)

(b) (2,9), (-6,4), (-1, -3) dan (8,1)

Jawapan/Answer: [52 unit²]

Jawapan/Answer: [88 $\frac{1}{2}$ unit²]

<p>(c) $(0,2), (-6,-2), (-3,-5)$ dan $(-1,-3)$</p> <p>Jawapan/Answer: [19 unit²]</p>	<p>(d) $(3,4), (-2,0), (2,-4)$ dan $(5,1)$</p> <p>Jawapan/Answer: [$27\frac{1}{2}$ unit²]</p>
-------------------------------------------------------------------------------------------------------------------------------	----------------------------------------------------------------------------------------------------------------------------------------------------

2. Bucu-bucu sebuah sisi empat $ABCD$ yang disusun mengikut tertib ialah $A(k, 6), B(-2,1), C(4,5)$ dan $D(2,8)$. Jika luas sisi empat $ABCD$ ialah 30 unit², cari nilai k .
 The vertices of a quadrilateral $ABCD$ arranged in order are $A(k, 6), B(-2,1), C(4,5)$ and $D(2,8)$. If area of the quadrilateral $ABCD$ is 30 unit², find the value of k .

Jawapan/Answer: [$k = -4$]

7.3.4 Membuat generalisasi tentang rumus luas polygon
Making generalisation about the formula of area of polygons

Contoh:
Example:
 Cari luas sebuah pentagon dengan bucu-bucunya ialah $(5, -2), (1, -1), (-1,1), (1,3)$ dan $(4,4)$.
 Find the area of a pentagon with vertices $(5, -2), (1, -1), (-1,1), (1,3)$ and $(4,4)$.
Penyelesaian:
Solution:

Dengan memplot bucu-bucu pentagon seperti dalam rajah di sebelah, bucu-bucu yang disusun mengikut tertib ialah $(4, 4), (1, 3), (-1, 1), (1, -1)$ dan $(5, -2)$.

Luas pentagon = $\frac{1}{2} \begin{vmatrix} 4 & 1 & -1 & 1 & 5 & 4 \\ 4 & 3 & 1 & -1 & -2 & 4 \end{vmatrix}$

$= \frac{1}{2} | (12 + 1 + 1 - 2 + 20) - (4 - 3 + 1 - 5 - 8) |$

$= \frac{1}{2} | 43 |$

$= 21\frac{1}{2}$ unit²

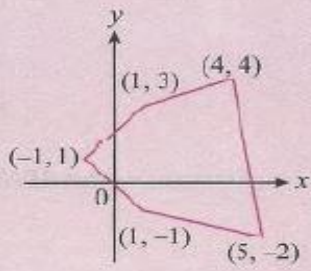

Latihan Kendiri/ Self Practice:

1. Sebuah pentagon $ABCDE$ mempunyai bucu-bucu $A(-2, -5)$, $B(3, 2)$, $C(2, 8)$, $D(0, 9)$ dan $E(-3, 1)$. Cari luas pentagon $ABCDE$.

A pentagon $ABCDE$ has vertices $A(-2, -5)$, $B(3, 2)$, $C(2, 8)$, $D(0, 9)$ and $E(-3, 1)$. Find the area of pentagon $ABCDE$.

Jawapan/Answer: $[46\frac{1}{2} \text{ unit}^2]$

2. Bucu-bucu sebuah heksagon ialah $(0, -1)$, $(-3, -1)$, $(-4, 2)$, $(-2, 6)$, $(1, 5)$ dan $(2, 1)$. Cari luas heksagon tersebut.
The vertices of a hexagon are $(0, -1)$, $(-3, -1)$, $(-4, 2)$, $(-2, 6)$, $(1, 5)$ and $(2, 1)$. Find the area of the hexagon.

Jawapan/Answer: $[30 \text{ unit}^2]$

7.3.5 Menyelesaikan masalah yang melibatkan luas polygon Solving problems involving areas of polygons

Contoh:**Example:**

Bucu-bucu bagi sebuah segi tiga ABC ialah $A(-4, -3)$, $B(7, 2)$ dan $C(-2, 3)$. M dan N masing-masing ialah titik tengah bagi sisi AC dan BC . Cari

The vertices of a triangle ABC are $A(-4, -3)$, $B(7, 2)$ dan $C(-2, 3)$. M and N are the midpoints of the sides AC and BC respectively. Find

(a) koordinat M dan N ,

the coordinates of M and N ,

(b) nisbah luas segi tiga CMN kepada luas sisi empat $ABNM$.

The ratio of area of triangle CMN to area of quadrilateral $ABNM$.

Penyelesaian:**Solution:**

$$\begin{aligned} \text{(a) Koordinat } M &= \left(\frac{-4 + (-2)}{2}, \frac{-3 + 3}{2} \right) \\ &= (-3, 0) \\ \text{Koordinat } N &= \left(\frac{-2 + 7}{2}, \frac{3 + 2}{2} \right) \\ &= \left(\frac{5}{2}, \frac{5}{2} \right) \end{aligned}$$

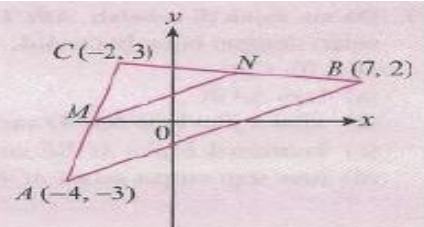

$$\begin{aligned} \text{(b) Luas segi tiga } CMN &= \frac{1}{2} \begin{vmatrix} -2 & -3 & \frac{5}{2} & -2 \\ 3 & 0 & \frac{5}{2} & 3 \end{vmatrix} \\ &= \frac{1}{2} \left| \left(0 - \frac{15}{2} + \frac{15}{2} \right) - (-9 + 0 - 5) \right| \\ &= \frac{1}{2} |14| \\ &= 7 \text{ unit}^2 \end{aligned}$$

$$\begin{aligned} \text{Luas sisi empat } ABNM &= \frac{1}{2} \begin{vmatrix} -4 & 7 & \frac{5}{2} & -3 & -4 \\ -3 & 2 & \frac{5}{2} & 0 & -3 \end{vmatrix} \\ &= \frac{1}{2} \left| \left(-8 + \frac{35}{2} + 0 + 9 \right) - \left(-21 + 5 - \frac{15}{2} + 0 \right) \right| \\ &= \frac{1}{2} |42| \\ &= 21 \text{ unit}^2 \end{aligned}$$

Maka, nisbah luas segi tiga CMN kepada luas sisi empat $ABNM$ ialah $7 : 21 = 1 : 3$.

Latihan Kendiri/ Self Practice:

1. Dalam rajah di sebelah, titik $A(-3, 0)$, $B(5, 2)$, C dan $D(-1, 6)$ ialah bucu-bucu sebuah segi empat selari $ABCD$. M ialah titik persilangan pepenjuru AC dan BD . Cari
In the diagram on the right, points $A(-3, 0)$, $B(5, 2)$, C and $D(-1, 6)$ are the vertices of a parallelogram $ABCD$. M is the intersection point of diagonals AC and BD . Find

- (a) koordinat C dan M ,
the coordinates of C and M ,
(b) nisbah luas $\triangle ABM$ kepada luas segi empat selari $ABCD$.
the ratio of the area of $\triangle ABM$ to the area of parallelogram $ABCD$.

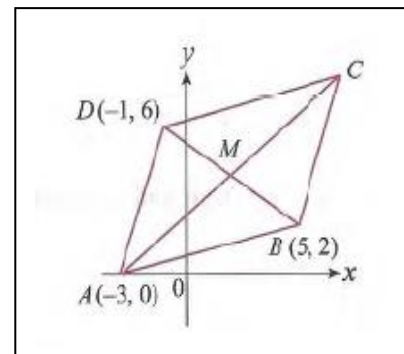

Jawapan/Answer: [(a) $C(7, 8)$, $M(2, 4)$ (b) $1 : 4$]

2. Garis lurus $y = 8 - 2x$ menyalang garis lurus $y = k$, $paksi - x$ dan $paksi - y$ masing-masing di titik P , Q dan R . Diberi bahawa luas bagi $\triangle OPR$ ialah 12 unit^2 , dengan O ialah asalan, cari

The straight line $y = 8 - 2x$ intersects the straight line $y = k$, x -axis and y -axis at points P , Q and R respectively. Given the area of $\triangle OPR$ is 12 unit^2 , with O as the origin, find

- (a) nilai terkecil k ,
the smallest value of k ,
(b) koordinat P .
the coordinates of P .

Jawapan/Answer: [(a) $k = 2$ (b) $P(3, 2)$]

3. Dalam rajah di sebelah, ABCD ialah sebuah segi empat selari dengan bucu-bucu A(4,-2), B (7,5), C (4,7) dan D (k,0). Cari

In the diagram on the right, ABCD is a parallelogram with vertices A(4,-2), B (7,5), C (4,7) and D (k,0). Find

- (a) luas ΔABC ,
the area of ΔABC
- (b) nilai k jika luas ΔACD sama dengan luas ΔABC ,
the value of k if the area of ΔACD is equal to the area of ΔABC ,
- (c) koordinat E jika $ACBE$ ialah sebuah segi empat selari,
the coordinates of E if $ACBE$ is a parallelogram,
- (d) luas segi empat selari $ACBE$
the area of parallelogram $ACBE$

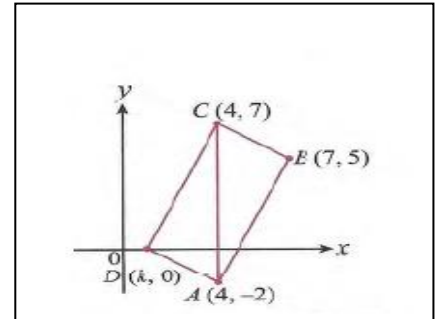

Jawapan/Answer: [(a) $13\frac{1}{2}$ unit² (b) $k = 1$]

Latihan Intensif/ Intensive Practice:

1. ABCD ialah sebuah segi empat selari dengan pepenjuru-pepenjurunya bertemu di E. Diberi A(-5,3), B(0,-2) dan C(3,5), cari

ABCD is a parallelogram which diagonals intersect at E. Given A(-5,3), B(0,-2) and C(3,5), find

- (a) koordinat D dan E
the coordinates of D and E
- (b) luas segi empat selari ABCD
the area of parallelogram ABCD.

Jawapan/Answer: [(a) D(-2,10), E(-1,4) (b) 50 unit²]

2. $PQRS$ ialah sebuah rombus dengan koordinat $P(3,3)$, $Q(h, 3)$, $R(-5, -1)$ dan $S(0, k)$. Cari
 $PQRS$ is a rhombus with coordinates $P(3,3)$, $Q(h, 3)$, $R(-5, -1)$ and $S(0, k)$. Find
- (a) nilai h dan nilai k ,
the value of h and k ,
 - (b) luas rombus $PQRS$
the area of rhombus $PQRS$

Jawapan/Answer: [(a) $h = -2, k = -1$ (b) 20 unit^2]

3. Diberi tiga titik, $A(-1, -5)$, $B(2,1)$ dan $C(6,9)$,
Given three points, $A(-1, -5)$, $B(2,1)$ and $C(6,9)$,
- (a) cari luas $\triangle ABC$.
find the area of $\triangle ABC$.
 - (b) berdasarkan jawapan di (a), apakah yang dapat anda katakan tentang titik A, B dan C ?
based on the answer in (a), what can you say about points A, B and C ?

Jawapan/Answer: [(a) 0 (b)Titik A, B dan C adalah segaris]

4. Cari luas bagi polygon dengan bucu-bucu $(5,2)$, $(-1,3)$, $(2,6)$, $(3, -2)$, $(-4,0)$ dan $(-3,2)$.
Find the area of a polygon with vertices $(5,2)$, $(-1,3)$, $(2,6)$, $(3, -2)$, $(-4,0)$ and $(-3,2)$.

Jawapan/Answer: [$47\frac{1}{2} \text{ unit}^2$]

5. Titik $A(5, -1)$, $B(3,3)$ dan $C(-6, p)$ ialah bucu-bucu sebuah segi tiga. Cari nilai-nilai p jika luas $\triangle ABC$ ialah 16 unit^2 .
Points $A(5, -1)$, $B(3,3)$ and $C(-6, p)$ are the vertices of a triangle. Find the values of p if the area of $\triangle ABC$ is 16 units^2 .

Jawapan/Answer: [5,37]

6. Diberi tiga titik, $P(2, 2r - 1)$, $Q(r - 1, r + 1)$ dan $R(r + 3, 0)$. Jika P , Q dan R terletak di atas satu garis lurus yang sama, cari nilai-nilai yang mungkin bagi r .
Given three points, $P(2, 2r - 1)$, $Q(r - 1, r + 1)$ and $R(r + 3, 0)$. If points P , Q and R are on the same straight line, find the possible values of r .

Jawapan/Answer: [1,5]

7. Tiga titik mempunyai koordinat $A(8, a)$, $B(-1, 2)$ dan $(3, 10)$. Cari nilai a jika
Tiga titik mempunyai koordinat $A(8, a)$, $B(-1, 2)$ dan $(3, 10)$. Cari nilai a jika
- (a) A , B dan C adalah segaris
 A , B and C are collinear
- (b) luas $\triangle ABC$ ialah 12 unit^2 .
The area of $\triangle ABC$ is 12 units^2 .

Jawapan/Answer: [(a)20 (b)14,26]

8. Rajah di sebelah menunjukkan sebuah segi tiga sama kaki EFG dengan bucu-bucu $E(0, k)$, $F(4, 4)$ dan $G(7, 8)$. EF dan FG adalah sama panjang.

The diagram on the right shows an isosceles triangle EFG with vertices $E(0, k)$, $F(4, 4)$ and $G(7, 8)$. EF and FG have the same length.

(a) Cari nilai k .

Find the value of k

(b) H ialah titik di atas garis $y = 11$ dengan keadaan $EH = GH$. Cari

H is a point on the line $y = 11$ such that $EH = GH$. Find

(i) koordinat H ,

coordinates of H ,

(ii) nisbah luas $\triangle EFG$ kepada luas sisi empat $EFGH$.

the ratio of area of $\triangle EFG$ to area of quadrilateral $EFGH$.

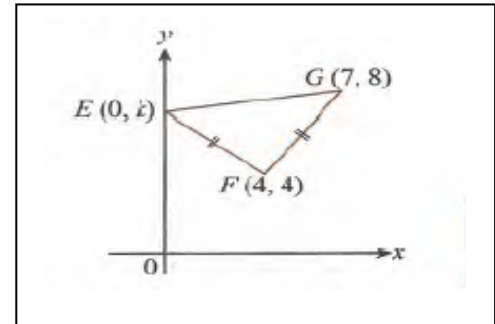

Jawapan/Answer: [(a) $k = 7$ (b)(i) $H(3, 11)$ (ii)1: 2]

9. Titik-titik $O(0, 0)$, $P(m + 1, m - 7)$, $Q(2m + 1, 2m)$ dan $R(m, m + 6)$ adalah bucu-bucu sebuah sisi empat dengan keadaan $m > 0$,

Points $O(0, 0)$, $P(m + 1, m - 7)$, $Q(2m + 1, 2m)$ and $R(m, m + 6)$ are the vertices of a quadrilateral such that $m > 0$,

(a) Jika luas $OPQR$ ialah $34 \frac{1}{2}$ unit², cari nilai m

if the area of $OPQR$ is $34 \frac{1}{2}$ units², find the value of m

(b) Seterusnya, cari luas $\triangle OPR$

Hence, find the area of $\triangle OPR$

Jawapan/Answer: [(a) $m = 2$ (b)17 unit²]

10. Koordinat bagi tiga stesen LRT, Paya Redan, Kampung Raja dan Panjang Sari masing-masing diwakili oleh titik $A(0,9)$, $B(7,0)$ dan $C(12,12)$, dengan keadaan 1 unit mewakili 100 m. Cari
The coordinates of three LRT stations, Paya Redan, Kampung Raja and Panjang Sari are represented by points $A(0,9)$, $B(7,0)$ and $C(12,12)$, such that 1 unit represents 100 m. Find
- jarak, dalam km, antara stesen LRT Paya Redan dan Kampung Raja.
The distance, in km, between Paya Redan Station and Kampung Raja Station.
 - luas sebenar, dalam km^2 , segi tiga yang dicakupi oleh tiga stesen itu.
The actual area, in km^2 , of the triangle formed by the three stations.

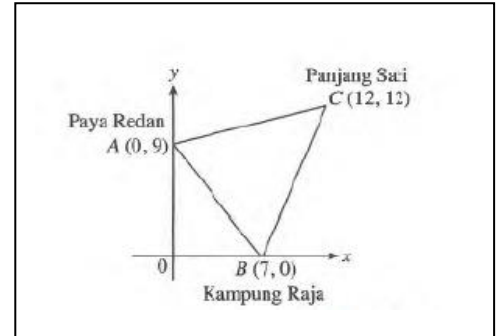

Jawapan/Answer: [(a)1.1402km (b)0.645 km^2]

7.4 Persamaan Lokus
Equations of Loci

7.4.1 Menentukan persamaan lokus
Determining the equation of locus

$$PA = r$$

$$\sqrt{(x - x_1)^2 + (y - y_1)^2} = r$$

$$(x - x_1)^2 + (y - y_1)^2 = r^2, \text{ dengan keadaan } r > 0$$

Contoh:

Example:

Cari persamaan lokus bagi titik bergerak P supaya jaraknya dari titik $A(4, -3)$ ialah 6 unit.
Find the equation of locus of moving point P so that its distance from point $A(4, -3)$ is 6 units.

Penyelesaian:

Solution:

Katakan koordinat titik P ialah (x, y) .
Jarak P dari $A = 6$

$$\sqrt{(x - 4)^2 + [y - (-3)]^2} = 6$$

$$(x - 4)^2 + (y + 3)^2 = 36$$

$$x^2 - 8x + 16 + y^2 + 6y + 9 = 36$$

$$x^2 + y^2 - 8x + 6y - 11 = 0$$

Maka, persamaan lokus P ialah $x^2 + y^2 - 8x + 6y - 11 = 0$.

Kuasa duakan di kedua-dua belah persamaan

Contoh:

Example:

Titik P bergerak dengan jaraknya dari titik $S(1,2)$ dan $T(4,-1)$ dalam nisbah 2:1. Cari persamaan locus bagi titik bergerak P .

Point P moves such that its distance from points $S(1,2)$ and $T(4,-1)$ is in the ration 2:1. Find the equation of locus of moving point P .

Penyelesaian:

Solution:

Katakan $P(x, y)$ ialah titik yang bergerak.

$$\frac{PS}{PT} = \frac{2}{1}$$

$$\frac{\sqrt{(x-1)^2 + (y-2)^2}}{\sqrt{(x-4)^2 + (y+1)^2}} = \frac{2}{1}$$

Kuasa duakan kedua-dua belah persamaan

$$\frac{(x-1)^2 + (y-2)^2}{(x-4)^2 + (y+1)^2} = \frac{4}{1}$$

$$x^2 - 2x + 1 + y^2 - 4y + 4 = 4(x^2 - 8x + 16 + y^2 + 2y + 1)$$

$$x^2 + y^2 - 2x - 4y + 5 = 4x^2 + 4y^2 - 32x + 8y + 68$$

$$3x^2 + 3y^2 - 30x + 12y + 63 = 0$$

Bahagikan setiap sebutan dengan 3

$$x^2 + y^2 - 10x + 4y + 21 = 0$$

Maka, persamaan locus bagi titik bergerak P ialah $x^2 + y^2 - 10x + 4y + 21 = 0$.

Contoh:

Example:

Cari persamaan locus bagi titik bergerak Q supaya jaraknya dari titik $A(2,3)$ dan titik $B(6,9)$ adalah sama. Find the equation of locus of a moving point Q such that its distance from point $A(2,3)$ and point $B(6,9)$ are the same.

Penyelesaian:

Solution:

Katakan $Q(x, y)$ ialah titik yang bergerak.

$$QA = QB$$

$$\sqrt{(x-2)^2 + (y-3)^2} = \sqrt{(x-6)^2 + (y-9)^2}$$

$$(x-2)^2 + (y-3)^2 = (x-6)^2 + (y-9)^2$$

$$x^2 - 4x + 4 + y^2 - 6y + 9 = x^2 - 12x + 36 + y^2 - 18y + 81$$

$$8x + 12y - 104 = 0$$

$$2x + 3y - 26 = 0$$

Maka, persamaan locus bagi titik bergerak Q ialah $2x + 3y - 26 = 0$.

Latihan Kendiri/ Self Practice:

- Cari persamaan locus bagi titik bergerak P supaya jaraknya dari setiap titik berikut ialah 3 unit.
Find the equation of locus of moving point P such that its distance from each of the following
(a) $(0,0)$ (b) $(2,3)$ (c) $(-4,5)$ (d) $(-1,-6)$

Jawapan/Answer: [(a) $x^2 + y^2 - 9 = 0$ (b) $x^2 + y^2 - 4x - 6y + 4 = 0$
(c) $x^2 + y^2 + 8x - 10y + 32 = 0$ (d) $x^2 + y^2 + 2x + 12y + 28 = 0$]

2. Titik P bergerak dengan keadaan jaraknya sentiasa 5 unit dari $Q(-2,1)$. Cari persamaan lokus bagi P .
Point P moves such that its distance from $Q(-2,1)$ is always 5 units. Find the equation of locus of point P .

Jawapan/Answer: [$x^2 + y^2 - 4x - 2y - 20 = 0$]

3. Cari persamaan lokus bagi titik bergerak P supaya jaraknya dari titik-titik tetap berikut dalam nisbah yang diberikan.

Find the equation of locus of moving point P such that its distance from the following fixed points is in the ratio given.

(a) $A(-2,0), B(4,0)$; nisbah/ratio 1:2

(b) $C(-3,0), D(2,5)$; nisbah/ratio 1:3

Jawapan/Answer: [$x^2 + y^2 + 8x = 0$]

Jawapan/Answer:
[$4x^2 + 4y^2 + 29x + 5y + 26 = 0$]

<p>(c) $E(0,2), F(-2,4)$; nisbah/ratio 3: 2</p> <p>Jawapan/Answer: [$5x^2 + 5y^2 + 36x - 56y + 164 = 0$]</p>	<p>(d) $R(1,2), S(4, -1)$; nisbah/ratio 2: 1</p> <p>Jawapan/Answer: [$x^2 + y^2 - 10x + 4y + 21 = 0$]</p>
<p>4. Koordinat titik J dan K masing-masing ialah $(-1,3)$ dan $(4,6)$. Titik Q bergerak dengan keadaan $QJ: QK = 2: 3$. Cari persamaan lokus bagi Q. The coordinates of points J and K are $(-1,3)$ and $(4,6)$ respectively. Point Q moves such that $QJ: QK = 2: 3$. Find the equation of locus of Q</p> <p>Jawapan/Answer: [$5x^2 + 5y^2 + 50x - 6y - 118 = 0$]</p>	
<p>5. Titik R bergerak supaya jaraknya dari titik $A(6,0)$ ialah dua kali jaraknya dari titik $B(-3,0)$. Cari persamaan lokus bagi R. Point R moves such that its distance from point $A(6,0)$ is twice its distance from point $B(-3,0)$. Find the equation of locus of point R.</p> <p>Jawapan/Answer: [$x^2 + y^2 + 12x = 0$]</p>	
<p>6. Titik P bergerak dalam nisbah $PO: PA = 1: 4$, dengan O ialah asalan dan koordinat titik A ialah $(2,0)$. Cari persamaan lokus bagi titik P. Point P moves in the ratio $PO: PA = 1: 4$, with O the origin and coordinates of point A being $(2,0)$. Find the equation of locus of point P.</p> <p>Jawapan/Answer: [$15x^2 + 15y^2 + 4x - 4 = 0$]</p>	

<p>7. Cari persamaan lokus bagi titik bergerak P supaya jaraknya dari titik-titik berikut adalah sama. Find the equation of locus of moving point P such that its distances from the following points are the same.</p>		
<p>(a) $A(-2,0)$ dan $B(0,4)$</p>	<p>(b) $C(-3,5)$ dan $D(2,-4)$</p>	<p>(c) $J(2,3)$ dan $K(6,8)$</p>
<p>Jawapan/Answer: [$x + 2y - 3 = 0$]</p>	<p>Jawapan/Answer: [$5x - 9y + 7 = 0$]</p>	<p>Jawapan/Answer: [$8x + 10y - 87 = 0$]</p>

7.4.2 Menyelesaikan masalah yang melibatkan lokus
Solving problems involving equations of loci

Contoh:

Example:

Seekor kambing diikat dengan tali pada sebatang tiang yang terletak di tengah-tengah sebuah padang. Panjang tali yang digunakan ialah 4 meter. Kambing itu berjalan di hujung tali yang tegang mengelilingi tiang seperti dalam rajah. Jika koordinat bagi tiang ialah $A(2,4)$, cari persamaan lokus bagi laluan kambing itu.

A goat is tied with a rope to a pole which is planted in the middle of a field. The length of rope used is 4 metres. The goat walks around the pole tied to the end of the taut rope as shown in the diagram. If the coordinates of the pole are $A(2,4)$, find the equation of locus of the goat's track.

Penyelesaian:

Solution:

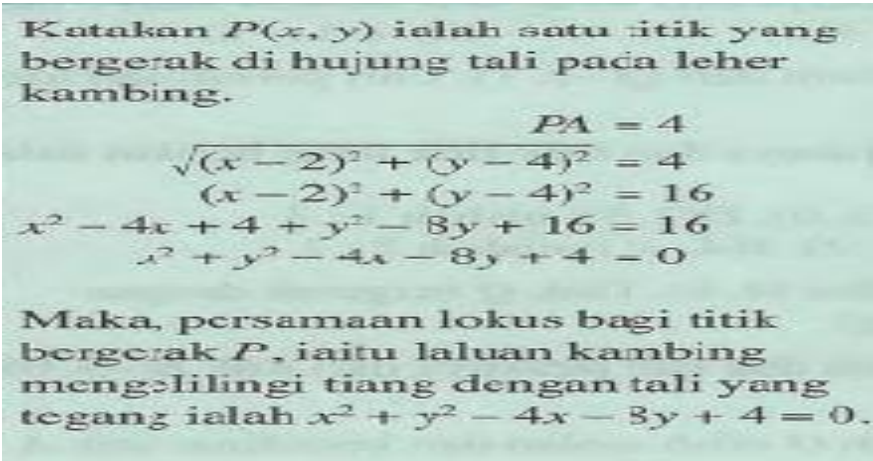

Katakan $P(x, y)$ ialah satu titik yang bergerak di hujung tali pada leher kambing.

$$PA = 4$$

$$\sqrt{(x-2)^2 + (y-4)^2} = 4$$

$$(x-2)^2 + (y-4)^2 = 16$$

$$x^2 - 4x + 4 + y^2 - 8y + 16 = 16$$

$$x^2 + y^2 - 4x - 8y + 4 = 0$$

Maka, persamaan lokus bagi titik bergerak P , iaitu laluan kambing mengelilingi tiang dengan tali yang tegang ialah $x^2 + y^2 - 4x - 8y + 4 = 0$.

Latihan Kendiri/ Self Practice:

1. Rajah di sebelah menunjukkan lokus bagi titik bergerak $P(x, y)$ yang menyentuh paksi- x pada satu titik dan berjarak tetap dari titik $A(3,4)$. Cari persamaan lokus bagi p .

The diagram on the right shows the locus of a moving point $P(x, y)$ that touches the x -axis at a point and is of locus of fixed distance from a point $A(3,4)$. Find the equation of locus of P .

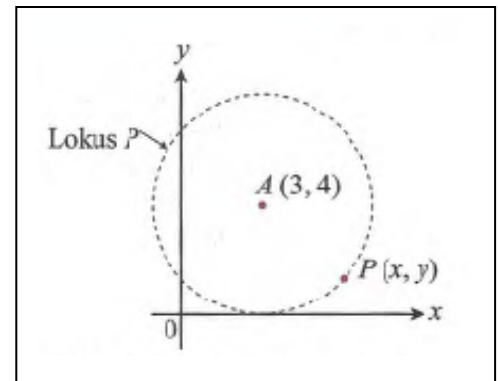

Jawapan/Answer: [$x^2 + y^2 - 6x - 8y + 9 = 0$]

2. Titik P bergerak dengan keadaannya sentiasa sama jarak dari titik $Q(8,7)$ dan titik $R(11,4)$. Titik S pula bergerak dengan jaraknya dari titik $T(7,8)$ adalah sentiasa 5 unit. Locus titik P dan locus titik S bersilang pada dua titik.

Point P moves such that it is always the same distance from the points $Q(8,7)$ and $R(11,4)$. Point S moves such that its distance from point $T(7,8)$ is always 5 units. The locus of point P and the locus of point S intersect at two points

(a) Cari persamaan locus bagi titik P .

Find the equation of locus of point P .

(b) Tunjukkan bahawa locus titik S ialah $x^2 + y^2 - 14x - 16y + 88 = 0$.

Show that the locus of point S is $x^2 + y^2 - 14x - 16y + 88 = 0$.

(c) Cari koordinat titik-titik persilangan bagi kedua-dua locus itu.

Find the coordinates of the intersection points of the two loci.

Jawapan/Answer: [(a) $x - y - 4 = 0$ (c)(7,3), (12,8)]

3. Dalam rajah di sebelah, titik $A(-2,0)$ dan titik $B(1,0)$ ialah dua titik tetap. Titik P bergerak di sepanjang bulatan dengan keadaan nisbah $PA;PB = 2:1$. Tunjukkan bahawa

In the diagram on the right point $A(-2,0)$ and point $B(1,0)$ are two fixed points. Point P moves along the circle such that the ratio $PA;PB = 2:1$. : Show that

- (a) persamaan bulatan ialah $x^2 + y^2 - 4x = 0$,
the equation of the circle is $x^2 + y^2 - 4x = 0$,
(b) titik $C(2,2)$ terletak pada bulatan itu.
point $C(2,2)$ is on the circle.

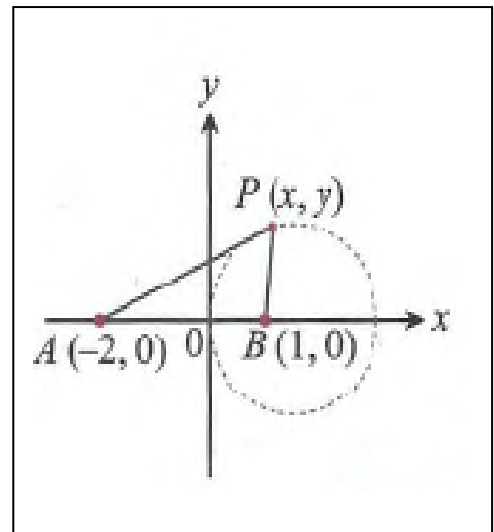

Latihan Intensif/ Intensive Practice:

1. Satu titik $R(x, y)$ bergerak supaya jaraknya dari dua titik tetap $A(-1,10)$ dan $B(2,6)$ adalah dengan keadaan $\frac{RA}{RB} = \frac{1}{2}$. Cari

A point moves so that its distance from two points $A(-1,10)$ and $B(2,6)$ is such that $\frac{RA}{RB} = \frac{1}{2}$. Find

- (a) persamaan bagi lokus R ,
the equation of locus of R ,
(b) koordinat titik bagi lokus R yang menyentuh paksi- y .
the coordinates of the point on locus R that touches the y -axis.

Jawapan/Answer: [(a) $3x^2 + 3y^2 + 12x - 68y + 364 = 0$ (b) $(0, \frac{26}{3}), (0,14)$]

2. Rajah di sebelah menunjukkan suatu tembereng garis AB masing-masing dengan koordinat $A(1,1)$ dan $B(7,9)$. Cari persamaan locus bagi titik bergerak S supaya segi tiga ABS sentiasa bersudut tegak di S .
The diagram on the right shows a line segment AB with coordinates $A(1,1)$ and $B(7,9)$. Find the equation of moving point S such that triangle ABS always has a right angle at S .

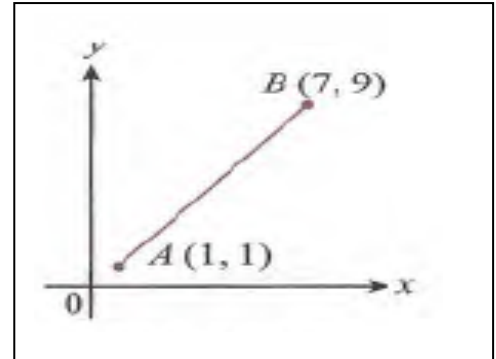

Jawapan/Answer: $[x^2 + y^2 - 8x - 10y + 16 = 0]$

3. Titik Q bergerak di sepanjang lengkok sebuah bulatan berpusat $(6,5)$. Lengkok bulatan itu melalui titik $R(2,8)$ dan $S(k, 2)$. Cari
Point Q moves along the arc of a circle with centre $(6,5)$. The arc of the circle passes through $R(2,8)$ and $S(k, 2)$. find
(a) Persamaan locus bagi Q ,
the equation of locus of Q ,
(b) nilai-nilai k .
the values of k .

Jawapan/Answer: $[(a)x^2 + y^2 - 12x - 10y + 36 = 0, (b)2,10]$

4. Rajah di sebelah menunjukkan locus bagi titik bergerak P dengan keadaan jaraknya dari titik $R(1,0)$ dan garis $x = -1$ adalah sama. Cari persamaan locus bagi titik bergerak P .
The diagram on the right shows the locus of moving point P such that its distance from point $R(1,0)$ and line $x = -1$ are the same. Find the equation of locus of moving point P .

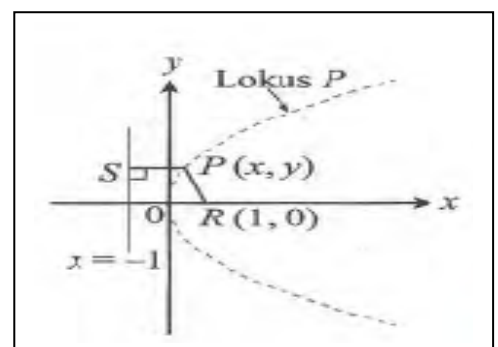

Jawapan/Answer: $[y^2 = 4x]$

5. Rajah di sebelah menunjukkan paksi- x dan paksi- y yang mewakili lantai dan dinding. Sebatang galah, LK disandarkan pada dinding dengan panjang 9 m menyentuh lantai dan dinding masing-masing pada titik $K(\alpha, 0)$ dan $L(0, \beta)$.

The diagram on the right shows the x -axis and y -axis which represent the floor and wall respectively. A pole LK of length 9 m leaning against the wall touches the floor and wall at $K(\alpha, 0)$ and $L(0, \beta)$ respectively.

(a) Tuliskan persamaan yang menghubungkan α dan β .

Write the equation which relates α dan β .

(b) Diberi $P(x, y)$ ialah satu titik pada galah itu dengan keadaan nisbah $LP:PK = 1:2$. Kedua-dua hujung galah itu menggelongsor di sepanjang paksi- x dan paksi- y . Cari persamaan lokus bagi titik P .

Given $P(x, y)$ is a point on the pole such that the ratio $LP:PK = 1:2$. Both ends of the pole slide along the x -axis and y -axis. Find the equation of locus of point P .

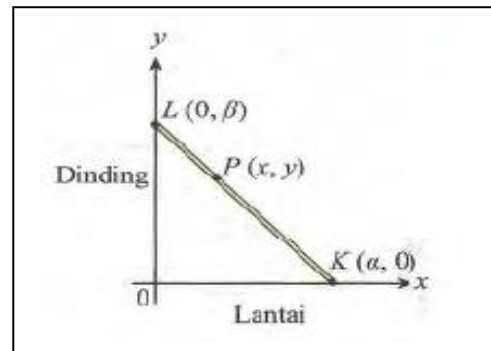

Jawapan/Answer: [(a) $\alpha^2 + \beta^2 = 81$ (b) $4x^2 + y^2 = 36$]

6. Seekor monyet diikat dengan seutas tali pada satu bucu sangkarnya yang berukuran $1\text{ m} \times 1\text{ m}$. Panjang tali itu ialah $2\frac{1}{2}\text{ m}$. Lakar dan terangkan lokus jika monyet itu bergerak lawan arah jam mengelilingi sangkarnya dengan tali yang tegang.

A monkey is tied to one vertex of his cage which measures $1\text{ m} \times 1\text{ m}$. with a rope. The length of the rope is $2\frac{1}{2}\text{ m}$. Sketch and explain locus if the monkey moves anticlockwise around the cage with taut.

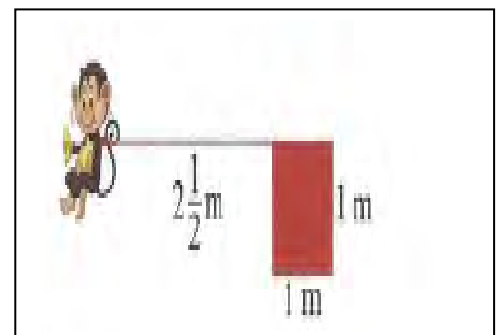

Jawapan/Answer:

(i) APQ iaitu sukuan bulatan berpusat A dan berjejari $2\frac{1}{2}\text{ m}$,

(ii) BQR iaitu sukuan bulatan berpusat B dan berjejari $2\frac{1}{2}\text{ m}$,

(iii) CRS iaitu sukuan bulatan berpusat C dan berjejari $\frac{1}{2}\text{ m}$

Soalan SPM 2003 K1 No 9

Titik-titik $A(2h, h)$, $B(p, t)$, dan $C(2p, 3t)$ terletak pada satu garis lurus. B membahagi dalam AC dengan nisbah 2: 3.

Ungkapkan p dalam sebutan t .

The points $A(2h, h)$, $B(p, t)$, and $C(2p, 3t)$ are on a straight line. B divides AC internally in the ratio 2: 3.

Express p in terms of t .

Jawapan/Answer: [$p = -2t$]

Soalan SPM 2003 K2 No 11

Penyelesaian secara lukisan berskala tidak diterima.

Solution to this question by scale drawing will not be accepted.

Titik P bergerak di sepanjang suatu lengkok bulatan yang berpusat $A(2,3)$. Lengkok bulatan itu melalui $Q(-2,0)$ dan $R(5, k)$.

A point P moves along the arc of a circle with centre $A(2,3)$. The arc passes through $Q(-2,0)$ and $R(5, k)$.

(a) Carikan

Find

(i) persamaan lokus bagi titik P ,

the equation of the locus of the point P ,

(ii) nilai-nilai k .

the values of k .

(b) Tangen kepada bulatan itu di titik Q bersilang dengan paksi- y di titik T . Carikan luas segi tiga OQT .

the tangent to the circle at point Q intersects the y -axis at point T . Find the area of triangle OQT .

Jawapan/Answer: [(a)(i) $x^2 + y^2 - 4x - 6y - 12 = 0$, (ii) $k = -1,7$ (b)luas = $\frac{8}{3}$]

Soalan SPM 2004 K1 No 14

Rajah 4 menunjukkan garis lurus PQ yang mempunyai persamaan $\frac{x}{2} + \frac{y}{3} = 1$. Titik P terletak pada paksi- x dan titik Q terletak pada paksi- y .

Diagram 4 shows a straight line PQ with the equation $\frac{x}{2} + \frac{y}{3} = 1$. The point P lies on the x -axis and the point Q lies on the y -axis.

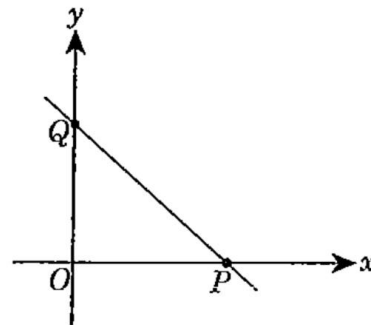
**Rajah 4**

Carikan persamaan garis lurus yang berserenjang dengan PQ dan melalui titik Q .

Find the equation of the straight line perpendicular to PQ and passing through the point Q .

Jawapan/Answer: $[y = \frac{2}{3}x + 3]$

Soalan SPM 2004 K1 No 15

Titik A ialah $(-1,3)$ dan titik B ialah $(4,6)$. Titik P bergerak dengan keadaan $PA:PB = 2:3$.

Carikan persamaan lokus bagi P .

The point A is $(-1,3)$ and the point B is $(4,6)$. The point P moves such that $PA:PB = 2:3$.

Find the equation of the locus of P .

Jawapan/Answer: $[5x^2 + 5y^2 + 50x - 6y - 118 = 0]$

Soalan SPM 2004 K2 No 2

Rajah 1 menunjukkan garis lurus CD yang bertemu dengan garis lurus AB di titik D . Titik C terletak pada paksi- y .

Diagram 1 shows a straight line CD which meets a straight line AB at the point D . The point C lies on the y -axis.

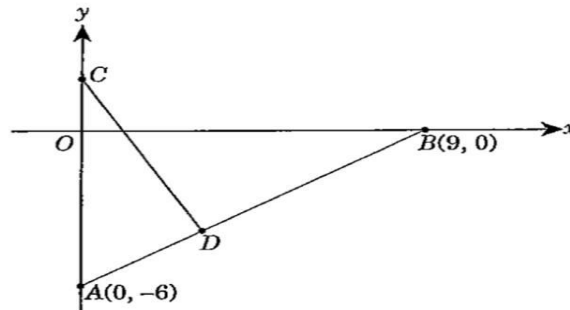

Rajah 1

- (a) Tuliskan persamaan AB dalam bentuk pintasan.
Write down the equation of AB in the form of intercepts.
- (b) Diberi $2AD = DB$, carikan koordinat D .
Given that $2AD = DB$, find the coordinates of D .
- (c) Diberi CD berserenjang dengan AB , carikan pintasan- y bagi CD .
Given that CD is perpendicular to AB , find the y -intercept of CD .

Jawapan/Answer: [(a) $\frac{x}{9} - \frac{y}{6} = 1$, (b) $(3, -4)$ (c) y -intercept = $\frac{1}{2}$]

Soalan SPM 2005 K1 No 14

Maklumat berikut adalah berkaitan dengan persamaan dua garis lurus, JK dan RT , yang berserenjang antara satu sama lain.

The following information refers to the equations of two straight lines, JK and RT , which are perpendicular to each other.

$$JK: y = px + k$$

$$RT: y = (k - 2)x + p$$

dengan keadaan p dan k ialah pemalar
where p and k are constants

Ungkapkan p dalam sebutan k .

Express p in terms of k .

Jawapan/Answer: $\left[p = \frac{1}{2-k} \right]$

Soalan SPM 2005 K2 No 9

Penyelesaian secara lukisan berskala tidak diterima.

Solution to this question by scale drawing will not be accepted.

Dalam Rajah 5, $\angle ABC = 90^\circ$ dan persamaan garis lurus BC ialah $2y + x + 6 = 0$

In diagram 5, $\angle ABC = 90^\circ$ and the equation of straight line BC is $2y + x + 6 = 0$

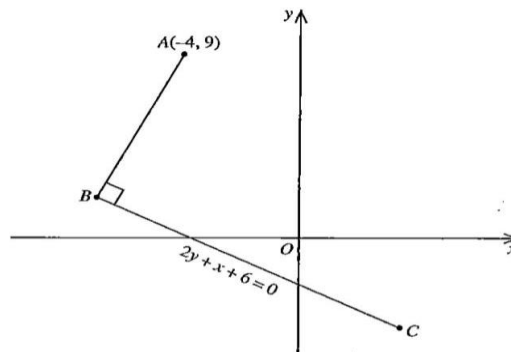

Diagram 5
Rajah 5

(a) Carikan

Find

(i) persamaan garis lurus AB

The equation of the straight line AB .

(ii) koordinat B .

The coordinates of B .

(b) Garis lurus AB dipanjangkan ke suatu titik D dengan keadaan $AB:BD = 2:3$. Carikan koordinat D .

The straight line AB is extended to a point D such that $AB:BD = 2:3$. Find the coordinates of D .

(c) Suatu titik P bergerak dengan keadaan jaraknya dari titik A adalah 5 unit. Carikan persamaan lokus bagi P .

A point P moves such that its distance from point A is always 5 units. Find the equation of the locus of P .

Jawapan/Answer: [(a)(i) $y = 2x + 17$ (ii) $B(-8, 1)$ (b) $D(-14, -11)$ (c) $x^2 + y^2 + 8x - 18y + 72 = 0$]

Soalan SPM 2006 K1 No 12

Rajah 5 menunjukkan garis lurus AB yang berserenjang dengan garis lurus CB pada titik B .

Diagram 5 shows the straight line AB which is perpendicular to the straight line CB at point B .

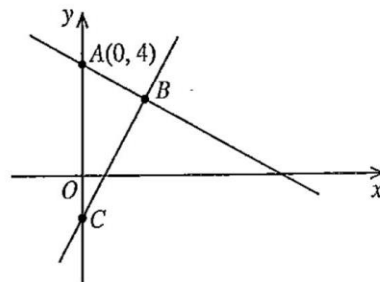

Diagram 5
Rajah 5

Persamaan garis lurus CB ialah $y = 2x - 1$. Cari koordinat B .

The equation of the straight line CB is $y = 2x - 1$. Find the coordinates of B .

Jawapan/Answer: [$B(2, 3)$]

Soalan SPM 2006 K2 No 9

Penyelesaian secara lukisan berskala tidak diterima.

Solution to this question by scale drawing will not be accepted.

Rajah 3 menunjukkan segi tiga AOB dengan keadaan O ialah asalan. Titik C terletak pada garis lurus AB .

Diagram 3 shows the triangle AOB where O is the origin. Point C lies on the straight line AB .

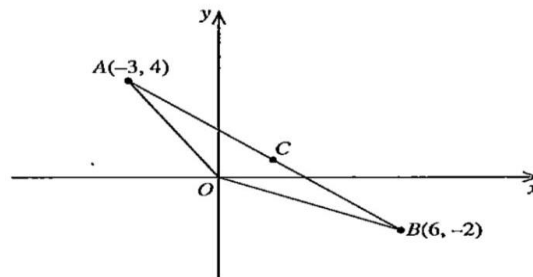

Diagram 3
Rajah 3

(a) Hitung luas, dalam unit^2 , segi tiga AOB

Calculate the area, in units^2 , of triangle AOB .

(b) Diberi $AC : CB = 3 : 2$, cari koordinat C .

Given that $AC : CB = 3 : 2$, find the coordinates of C .

(c) Suatu titik P bergerak dengan keadaan jaraknya dari titik A adalah sentiasa dua kali jaraknya dari titik B .

A point P moves such that its distance from point A is always twice its distance from point B .

(i) Cari persamaan locus bagi P .

Find the equation of the locus of P .

(ii) Seterusnya, tentukan sama ada locus itu memintas paksi- y atau tidak.

Hence, determine whether this locus intersects the y -axis.

Jawapan/Answer: [(a) 9 unit^2 , (b) $(\frac{12}{5}, \frac{2}{5})$ (c)(i) $x^2 + y^2 - 18x + 8y + 45 = 0$ (ii) $b^2 - 4ac < 0$, tidak bersilang pada paksi- y]

Soalan SPM 2007 K1 No 13

Garis lurus $\frac{x}{6} + \frac{y}{h} = 1$ mempunyai 2 sebagai pintasan-y dan adalah selari dengan garis lurus $y + kx = 0$. Tentukan nilai h dan nilai k .

The straight line $\frac{x}{6} + \frac{y}{h} = 1$ has a y -intercept of 2 and is parallel to the straight line $y + kx = 0$. Determine the value of h and of k .

Jawapan/Answer: $\left[h = 2, k = \frac{1}{3} \right]$

Soalan SPM 2007 K1 No 14

Bucu-bucu sebuah segi tiga ialah $A(5,2)$, $B(4,6)$ dan $C(p, -2)$. Diberi luas segi tiga itu ialah 30 unit^2 , cari nilai-nilai p .

The vertices of a triangle are $A(5,2)$, $B(4,6)$ and $C(p, -2)$. Given that the area of the triangle is 30 unit^2 , find the values of p .

Jawapan/Answer: $[p = -9, p = 21]$

Soalan SPM 2007 K2 No 2

Penyelesaian secara lukisan berskala tidak diterima.

Solution to this question by scale drawing will not be accepted.

Dalam Rajah 1, garis lurus AB mempunyai persamaan $y + 2x + 8 = 0$. AB menyalang paksi- x di titik A dan menyalang paksi- y di titik B .

In diagram 1, the straight line AB has an equation $y + 2x + 8 = 0$. AB intersects the x -axis at point A and intersects the y -axis at point B .

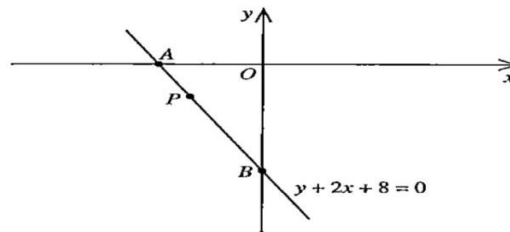

Diagram 1
Rajah 1

Titik P terletak pada AB dengan keadaan $AP:PB = 1:3$.

Point P lies on AB such that $AP:PB = 1:3$.

Cari

Find

(a) koordinat P

the coordinates of P

(b) persamaan garis lurus yang melalui P dan berserenjang dengan AB

the equation of the straight line that passes through P and is perpendicular to AB .

Jawapan/Answer: [(a) $P(-3, -2)$ (b) $2y = x - 1$]

Soalan SPM 2008 K1 No 13

Rajah 13 menunjukkan garis lurus yang melalui $S(3,0)$ dan $T(0,4)$.

Diagram 13 shows a straight line passing through $S(3,0)$ and $T(0,4)$.

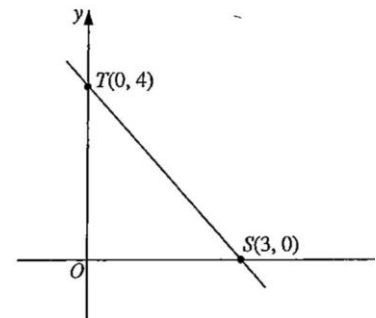

Diagram 13
Rajah 13

(a) Tulis persamaan garis lurus ST dalam bentuk $\frac{x}{a} + \frac{y}{b} = 1$.

Write down the equation of the straight line ST in the form $\frac{x}{a} + \frac{y}{b} = 1$.

(b) Suatu titik $P(x, y)$ bergerak dengan keadaan $PS = PT$. Cari persamaan lokus bagi P .

A point $P(x, y)$ moves that $PS = PT$. Find the equation of the locus of P .

Jawapan/Answer: $\left[(a) ST: \frac{x}{3} + \frac{y}{4} = 1, (b) 6x - 8y + 7 = 0 \right]$

Soalan SPM 2008 K1 No 14

Titik-titik $(0,3)$, $(2, t)$ dan $(-2,1)$ ialah bucu-bucu sebuah segi tiga. Diberi luas segi tiga itu ialah 4 unit², cari nilai-nilai t .

The points $(0,3)$, $(2, t)$ and $(-2,1)$ are the vertices of a triangle. Given that the area of the triangle is 4 unit², find the values of t .

Jawapan/Answer: $[t = 3, t = 11]$

Soalan SPM 2008 K2 No 10

Penyelesaian secara lukisan berskala tidak diterima.

Solution to this question by scale drawing will not be accepted.

Rajah 10 menunjukkan segi tiga OPQ . Titik S terletak pada garis PQ .

Diagram 10 shows a triangle OPQ . Point S lies on the line PQ .

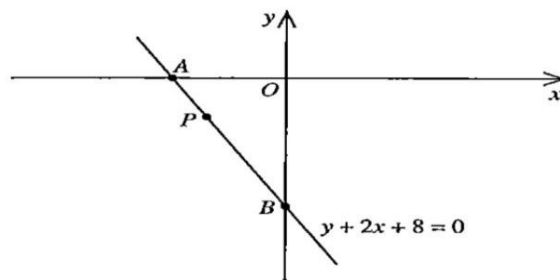

Diagram 1
Rajah 1

(a) Suatu titik W bergerak dengan keadaan jaraknya dari S adalah sentiasa $2\frac{1}{2}$ unit. Cari persamaan lokus W .

A point W moves such that its distance from point S is always $2\frac{1}{2}$ units. Find the equation of the locus of W .

(b) Diberi bahawa titik P dan titik Q terletak pada lokus W .

It is given that point P and point Q lie on the locus of W .

Hitung

Calculate

(i) nilai k

the value of k

(ii) koordinat Q

the coordinates of Q .

Jawapan/Answer: [(a) $4x^2 + 2y^2 - 24x - 8y + 15 = 0$ (b)(i) $k = 3$ (ii) $Q(\frac{9}{2}, -1)$]

Soalan SPM 2009 K1 No 15

Rajah 15 menunjukkan garis lurus AC .

Diagram 15 shows a straight line AC .

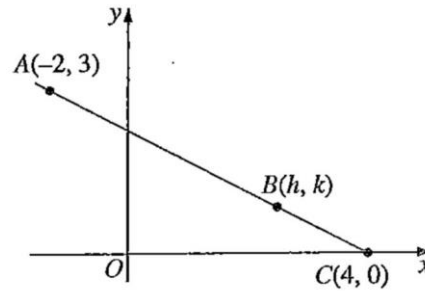

Diagram 15
Rajah 15

Titik B terletak di atas AC dengan keadaan $AB:BC = 3:1$. Cari koordinat B .

The point B lies on AC such that $AB:BC = 3:1$. Find the coordinates of B .

Jawapan/Answer: $(\frac{5}{2}, \frac{3}{4})$

Soalan SPM 2009 K2No 9

Penyelesaian secara lukisan berskala tidak diterima.

Solution to this question by scale drawing will not be accepted.

Rajah 9 menunjukkan sebuah trapezium $OABC$. Garis OA berserenjang dengan garis AB yang bersilang dengan paksi- y pada titik Q . Diberi bahawa persamaan OA ialah $y = -\frac{3}{2}x$ dan persamaan AB ialah $6y = kx + 26$.

Diagram 9 shows a trapezium $OABC$. The line OA is perpendicular to the line AB , which intersects the y -axis at the point Q . It is given that the equation of OA is $y = -\frac{3}{2}x$ and the equation of AB is $6y = kx + 26$.

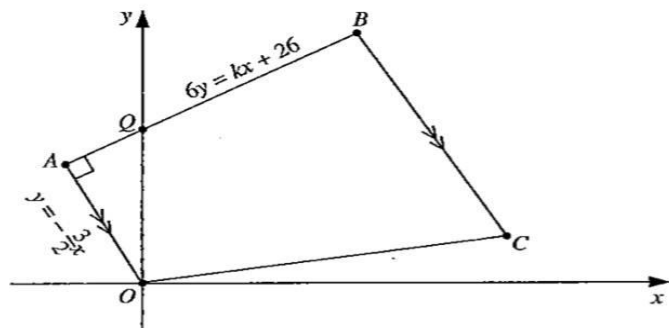

Diagram 9
Rajah 9

(a) Cari
Find

(i) nilai k
the value of k .

(ii) koordinat A

the coordinates of A

(b) diberi $AQ:QB = 1:2$, cari

given $AQ:QB = 1:2$, find

(i) koordinat B

the coordinates of B

(ii) persamaan garis lurus BC

the equation of the straight line BC

(c) suatu titik $P(x, y)$ bergerak dengan keadaan $2PA = PB$. Cari persamaan lokus P .

a point $P(x, y)$ moves such that $2PA = PB$. Find the equation of the locus of P .

Jawapan/Answer: [(a)(i) $k = 4$, (ii) $A(-2, 3)$ (b)(i) $B(4, 7)$ (ii) $2y + 3x = 26$ (c) $3x^2 + 3y^2 + 24x - 10y - 13 = 0$]

Soalan SPM 2010 K1 No 13

Suatu garis lurus melalui $A(-2, -5)$ dan $B(6, 7)$.

A straight line passes through $A(-2, -5)$ and $B(6, 7)$.

(a) Diberi $C(h, 10)$ terletak di atas garis lurus AB . Cari nilai h .

Given $C(h, 10)$ lies on the straight line AB . Find the value of h .

(b) Titik D membahagikan tembereng garis AB dalam nisbah 1:3. Cari koordinat D .

Point D divides the line segment AB in the ratio 1:3. Find the coordinates of D .

Jawapan/Answer: [(a) $h = 8$ (b) $D(0, -2)$]

Soalan SPM 2010 K1 No 14

Titik P bergerak dengan keadaan jaraknya sentiasa 5 unit dari $Q(-3,4)$. Cari persamaan lokus bagi P .
Point P moves such that its distance is always 5 unit from $Q(-3,4)$. Find the equation of the locus of P .

Jawapan/Answer: $[x^2 + y^2 + 6x - 8y = 0]$

Soalan SPM 2010 K2 No 5

Penyelesaian secara lukisan berskala tidak diterima.

Solution to this question by scale drawing will not be accepted.

Rajah 5 menunjukkan garis lurus AC yang bersilang dengan paksi- y pada titik B .

Diagram 5 shows the straight line AC which intersects the y -axis at point B .

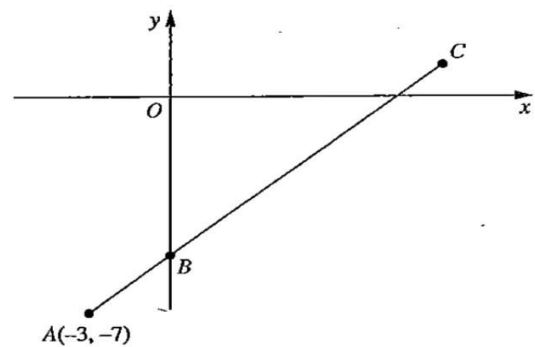

Diagram 5
Rajah 5

Persamaan AC ialah $3y = 2x - 15$

The equation of AC is $3y = 2x - 15$

Cari

Find

(a) persamaan garis lurus yang melalui titik A dan berserenjang dengan AC .

the equation of the straight line which passes through point A and is perpendicular to AC .

(b)(i) koordinat B

the coordinates of B

(ii) koordinat C , diberi $AB:BC = 2:7$

the coordinates of C , given $AB:BC = 2:7$

Jawapan/Answer: $\left[(a) 3x + 2y + 23 = 0 \quad (b)(i) B(0, -5) \quad (ii) C\left(\frac{21}{2}, 2\right) \right]$

Soalan SPM 2011 K1 No 13

Garis lurus $\frac{x}{2} + \frac{y}{6} = 1$ memotong paksi- x di P dan paksi- y di Q.

A straight line $\frac{x}{2} + \frac{y}{6} = 1$ cuts the x -axis at P and y -axis at Q.

Cari

Find

- (a) kecerunan garis lurus
the gradient of the straight line
- (b) persamaan pembahagi dua sama serenjang garis lurus itu.
the equation of the perpendicular bisector of the straight line.

Jawapan/Answer: [(a) -3 (b) $x - 3y + 8 = 0$]

Soalan SPM 2011 K2 No 5

Penyelesaian secara lukisan berskala tidak diterima.

Solution to this question by scale drawing will not be accepted.

Rajah 5 menunjukkan suatu garis lurus AB.

Diagram 5 shows a straight line AB.

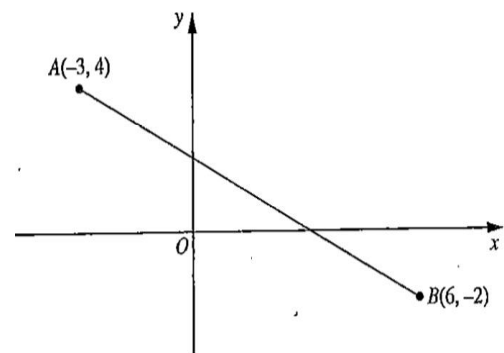

Diagram 5
Rajah 5

- (a) Hitung luas segi tiga AOB
Calculate the area of triangle AOB
- (b) Titik C membahagi dalam garis lurus AB dengan nisbah $AC:CB = 3:2$. Cari koordinat C .
Point C divides the straight line AB internally in the ratio $AC:CB = 3:2$
- (c) Titik P bergerak dengan keadaan jaraknya dari A adalah sentiasa dua kali jaraknya dari B. Cari persamaan lokus bagi P.
Point P moves such that its distance from A is always twice its distance from B. Find the equation of the locus of P.

Jawapan/Answer: [(a) 9 unit^2 (b) $C\left(\frac{12}{5}, \frac{2}{5}\right)$ (c) $3x^2 + 3y^2 - 54x + 24y + 135 = 0$]

Soalan SPM 2012 K1 No 13

Rajah 13 menunjukkan suatu garis lurus AB .

Diagram 13 shows a straight line AB .

Cari

Find

- (a) titik tengah AB
the midpoint of AB
- (b) persamaan pembahagi dua sama serenjang AB
the equation of the perpendicular bisector of AB .

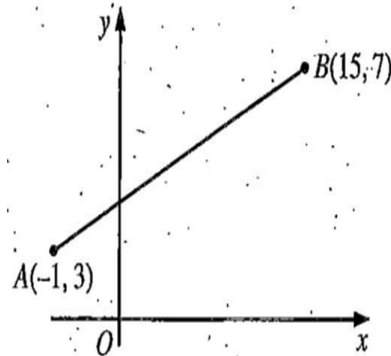

Diagram 13

Jawapan/Answer: [(a)(7,5)(b) $y = -4x + 33$]

Soalan SPM 2012 K1 No 14

Rajah 14 menunjukkan satu garis lurus PQ yang mempunyai persamaan $\frac{x}{10} + \frac{y}{2k} = 1$.

Diagram 14 shows a straight line PQ with the equation $\frac{x}{10} + \frac{y}{2k} = 1$.

Tentukan nilai

Determine the value of

- (a) h ,
- (b) k .

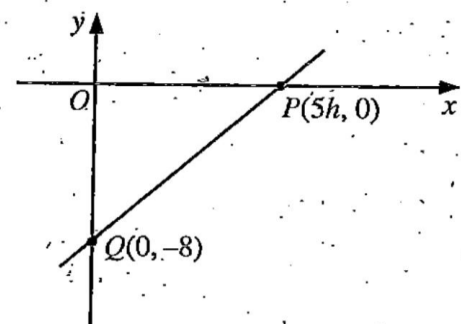

Diagram 14
Rajah 14

Jawapan/Answer: [(a) $h = 2$ (b) $k = -4$]

Soalan SPM 2012 K2 No 10

Penyelesaian secara lukisan berskala tidak diterima.

Solution to this question by scale drawing will not be accepted.

Rajah 10 menunjukkan sisi empat $PQRS$. Garis lurus PQ adalah berserenjang dengan garis lurus PS . Titik T terletak pada garis lurus PS .

Diagram 10 shows a quadrilateral $PQRS$. The straight PQ is perpendicular to the straight line PS . Point T lies on the straight line PS .

Cari

Find

- persamaan garis lurus PS .
the equation of the straight line PS
- koordinat S
the coordinates of S
- koordinat T jika $PT:TS = 1:3$
the coordinates of T if $PT:TS = 1:3$
- koordinat R jika luas sisi empat $PQRS$ ialah 30 unit^2 .
the coordinates of R if the area of quadrilateral $PQRS$ is 30 unit^2 .

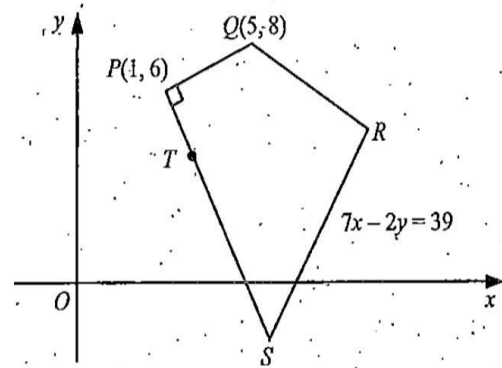

Diagram 10
Rajah 10

Jawapan/Answer: [(a) $y = -2x + 8$ (b) $S = (5, -2)$ (c) $T = (2, 4)$, (d) $R(7, 5)$]

Soalan SPM 2013 K1 No 13

Rajah 13 menunjukkan satu garis lurus AB .

Diagram 13 shows a straight line AB .

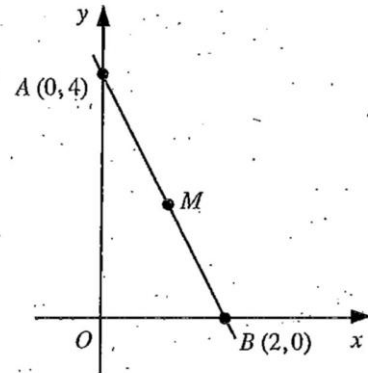

Diberi M ialah titik tengah of AB , cari

Given M ialah titik tengah AB , cari

(a) koordinat M ,

the coordinates of M ,

(b) persamaan garis lurus yang berserenjang dengan AB dan melalui M .

the equation of the straight line which is perpendicular to AB and passing through M .

Jawapan/Answer: [(a) $M(1,2)$ (b) $2y = x + 3$]

Soalan SPM 2013 K1 No 14

Titik B ialah $(5,0)$. A point $P(x, y)$ moves such that $PB = 3$. Cari persamaan lokus bagi P .

The point B is $(5,0)$. A point $P(x, y)$ moves such that $PB = 3$. Find the equation of the locus of P .

Jawapan/Answer: [$x^2 + y^2 - 10x + 16 = 0$]

Soalan SPM 2013 K2 No 9

Penyelesaian secara lukisan berskala tidak diterima.

Solution to this question by scale drawing will not be accepted.

Rajah 9 menunjukkan sebuah segi empat tepat $ABCD$. Persamaan garis lurus AB ialah $y = 2x + 3$.

Diagram 9 shows rectangle $ABCD$. The equation of the straight line AB is $y = 2x + 3$.

Cari

Find

(a) persamaan garis lurus DC

The equation of the straight line DC

(b) persamaan garis lurus AD

The equation of the straight line AD

(c) koordinat D

The coordinates of D

(d) luas, dalam unit^2 , segi empat tepat $ABCD$.

The area, in unit^2 , of rectangle $ABCD$

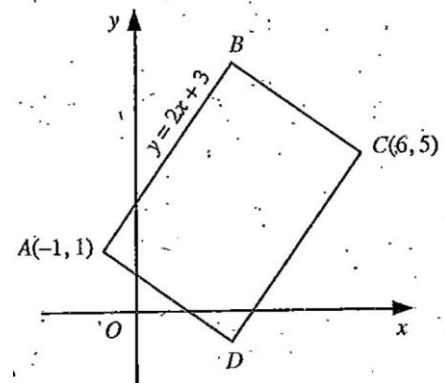

Diagram 9
Rajah 9

Jawapan/Answer: [(a) $y = 2x - 7$ (b) $2y + x = 1$ (c) $D(3, -1)$ (d) 30 unit^2]

Soalan SPM 2014 K1 No 12

Rajah 12 menunjukkan garis lurus PQ dengan persamaan $\frac{x}{5} + \frac{y}{7} = 1$ bersilang dengan garis lurus AB pada titik P .

Diagram 12 shows the straight line PQ with equation $\frac{x}{5} + \frac{y}{7} = 1$ intersects the straight line AB at point P .

- (a) Nyatakan pintasan- y bagi PQ

State the y -intercept of PQ .

- (b) Cari koordinat B jika $BP = 2PA$.

Find the coordinates of B if $BP = 2PA$.

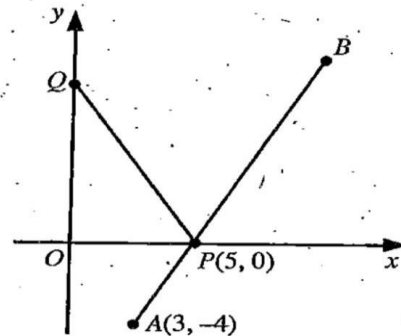

Diagram 12
Rajah 12

Jawapan/Answer: [(a) y - intercept = 7 (b) $B(9,8)$]

Soalan SPM 2014 K1 No 13

Garis lurus $y = -3x + 8$ adalah selari dengan garis lurus $y = (k + 2)x + 7$, dengan keadaan k ialah pemalar. Tentukan nilai k .

The straight line $y = -3x + 8$ is parallel to the straight line $y = (k + 2)x + 7$, where k is a constant. Determine the value of k .

Jawapan/Answer: [$k = -5$]

Soalan SPM 2014 K2 No 10

Rajah 10 menunjukkan sisi empat PQRS. Titik R terletak pada paksi-y.

Diagram 10 shows a quadrilateral PQRS. Point R lies on the y-axis.

Persamaan garis lurus PS ialah $2y = 5x - 21$

The equation of a straight line PS is $2y = 5x - 21$

(a) Cari

Find

(i) persamaan garis lurus PQ

The equation of the straight line PQ .

(ii) koordinat P .

the coordinates of P .

(b) Titik T bergerak dengan keadaan jaraknya dari titik S sentiasa 5 unit. Cari persamaan lokus T .

A point T moves such that its distance from point S is always 5 units. Find the equation of the locus of T .

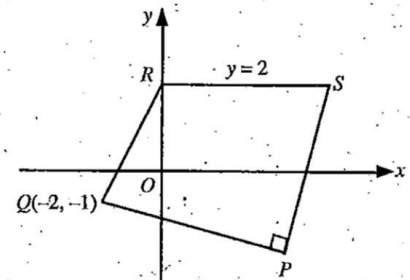

Diagram 10
Rajah 10

Jawapan/Answer: [(i) $5y = -2x - 9$ (ii) $p = (3, -3)$ (b) $x^2 + y^2 - 10x - 4y + 4 = 0$]

Soalan SPM 2015 K1 No 11

Persamaan suatu garis lurus diberi oleh $px + qy - 1 = 0$, dengan keadaan p dan q ialah pemalar:

The equation of a straight line is given by $px + qy - 1 = 0$, where p and q are constants:

Cari dalam sebutan p dan q

Find in terms of p and q

(a) kecerunan garis lurus itu

the gradient of the straight line

(b) kecerunan garis lurus yang berserenjang dengan garis $px + qy - 1 = 0$

the gradient of the straight line which is perpendicular to the line $px + qy - 1 = 0$

Jawapan/Answer: $\left[(a) -\frac{p}{q} \quad (b) \frac{q}{p} \right]$

Soalan SPM 2015 K1 No 12

Rajah 12 menunjukkan kedudukan dua ekor lebah, P dan Q .

Diagram 12 shows the position of two bees, P and Q .

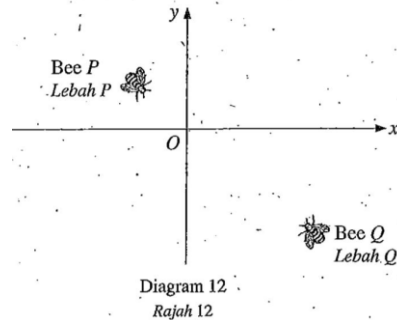

Koordinat bagi lebah P dan lebah Q masing-masing adalah $(-4,4)$ dan $(8,-12)$. Kedua-dua lebah itu terbang ke arah satu sama lain pada satu garis lurus dengan halaju berbeza. Halaju lebah P adalah tiga kali ganda halaju lebah Q . Cari jarak lebah P dari titik asalnya apabila ia bertemu dengan lebah Q .

The coordinates of bee P and bee Q are $(-4,4)$ and $(8,-12)$ respectively. Both bees fly towards each other on a straight line with different velocity. The velocity of bee P is three times the velocity of bee Q .

Jawapan/Answer: [15 units]

Soalan SPM 2015 K2 No 3

Penyelesaian secara lukisan berskala tidak diterima.

Solution to this question by scale drawing will not be accepted.

Rajah 3 menunjukkan sebuah tapak perkhemahan $OPQR$ yang telah dibersihkan oleh sekumpulan pengakap. Titik-titik A, B dan C adalah masing-masing pusat khemah A, B dan C . A, B dan C adalah segaris.

Diagram 3 shows a campsite $OPQR$ that had been cleared by a group of scouts. Points A, B and C are the centre of the tents A, B and C respectively. A, B and C are collinear.

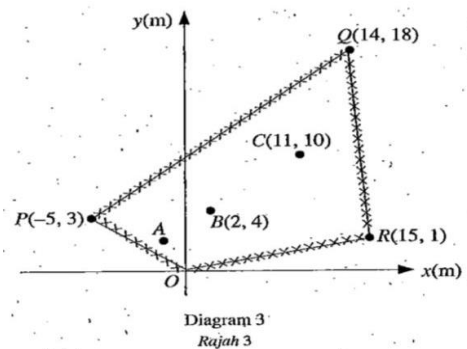

Diberi jarak titik C ialah 3 kali ganda dari titik B dan 4 kali ganda dari titik A .

Given the distance of point C is 3 times from point B and 4 times from point A .

(a) Cari

Find

(i) luas, dalam m^2 , tapak perkhemahan $OPQR$

The area, in m^2 , of the campsite $OPQR$

(ii) koordinat A .

Coordinates of A .

(b) Seorang pengakap menabur serbuk belerang di sekeliling khemah C dengan keadaan jarak laluan serbuk belerang dari pusat khemah C ialah sentiasa 3 m. Cari persamaan laluan serbuk belerang itu.

A scout spread sulphur powder around tent C such that the distance of the sulphur powder track from the centre of tent C is always 3 m. Find the equation of the track of the sulphur powder.

Jawapan/Answer: [(a)(i) $194m^2$ (ii) $A(-1,2)$ (b) $x^2 + y^2 - 22x - 20y + 212 = 0$]

Soalan SPM 2016 K1 No 8

Garis lurus $2y = 3x + h + 4$ menyilang paksi- y pada $5k$, dengan keadaan h dan k ialah pemalar. Ungkapkan h dalam sebutan k .

The straight line $2y = 3x + h + 4$ intersects the y -axis at $5k$, where h and k are constants. Express h in terms of k .

Jawapan/Answer: [$h = 9k$]

Soalan SPM 2016 K1 No 9

Rajah 9 menunjukkan dua garis lurus pada suatu satah Cartes.

Diagram 9 shows two straight lines on a Cartesian plane.

Kedua-dua garis lurus itu berserenjang antara satu sama lain.

Both the straight are perpendicular to each other.

(a) Nyatakan nilai q

State the value of q .

(b) Cari koordinat F .

Find the coordinates of F .

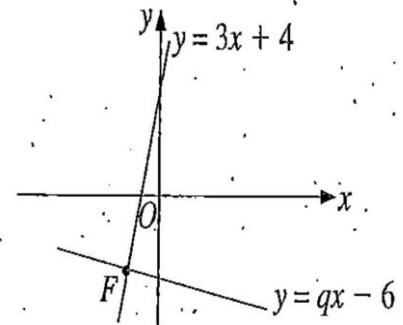

Diagram 9

Rajah 9

Jawapan/Answer: [(a) $q = -\frac{1}{3}$ (b) $F(-3, -5)$]

Soalan SPM 2016 K2 No 11

Penyelesaian secara lukisan berskala tidak diterima.

Solution to this question by scale drawing will not be accepted.

Rajah 11 menunjukkan segi tiga ACD . Sisi AC bersilang dengan paksi- y pada titik B .

Diagram 11 shows a triangle ACD . Side AC intersects the y -axis at point B .

(a) diberi $AB:BC = 2:3$, cari

given $AB:BC = 2:3$, find

(i) koordinat A ,

the coordinates of A ,

(ii) persamaan garis lurus AD

the equation of the straight line AD

(iii) luas, dalam unit², segi tiga ACD

the area, in unit², of triangle ACD

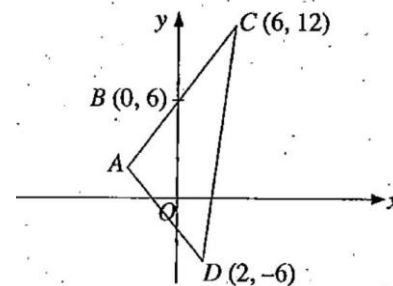

Diagram 11

Rajah 11

(b) Titik P bergerak dengan keadaan jaraknya dari titik C adalah sentiasa dua kali jaraknya dari titik D . Cari persamaan lokus P .

Point P moves such that its distance from point C is always twice its distance from point D . Find the equation of the locus P .

Jawapan/Answer: [(a)(i)A(-4,2)(ii) $3y = -4x - 10$ (iii)70 unit² (b) $3x^2 + 3y^2 - 4x + 72y - 20 = 0$]

Soalan SPM 2017 K1 No 18

Satu garis lurus melalui $P(3,1)$ dan $Q(12,7)$. Titik R membahagi tembereng garis PQ dengan keadaan $2PQ = 3RQ$. Cari koordinat R .

A straight line passes through $P(3,1)$ and $Q(12,7)$. The point R divides the line segment PQ such that $2PQ = 3RQ$. Find the coordinates of R .

Jawapan/Answer: [$R(6,3)$]

Soalan SPM 2017 K2 No 5

Penyelesaian secara lukisan berskala tidak diterima.

Solution to this question by scale drawing will not be accepted.

Rajah 3 menunjukkan kedudukan bagi bandar A dan bandar B yang dilukis pada suatu satah Cartes.

Diagram 3 shows the locations of town A and town B drawn on Cartesian plane.

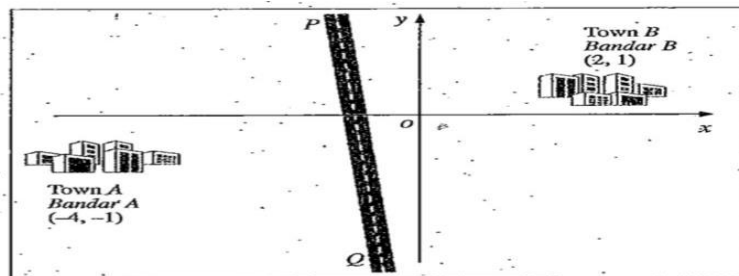

Diagram 3
Rajah 3

PQ ialah jalan raya lurus dengan keasaan jarak dari bandar A dan bandar B ke mana-mana titik pada jalan raya adalah sentiasa sama.

PQ is a straight road such that the distance from town A and town B to any point on the road is always equal.

(a) Cari persamaan bagi PQ

Find the equation of PQ

(b) Satu lagi jalan raya lurus, ST dengan persamaan $y = 2x + 7$ akan dibina.

Another straight road, ST with an equation $y = 2x + 7$ is to be built.

(i) Lampu isyarat akan dipasang di persimpangan kedua-dua jalan raya itu. Cari koordinat bagi lampu isyarat itu.

A traffic light is to be installed at the crossroads of the two roads. Find the coordinates of the traffic light.

(ii) Antara dua jalan raya itu, yang manakah melalui bandar $C(-\frac{4}{3}, 1)$?

Which of the two roads passes through town $C(-\frac{4}{3}, 1)$?

Jawapan/Answer: [(a) $3x + y + 3 = 0$ (b)(i) $(-2, 3)$ (ii) $3x + y + 3 = 0$ melalui C

Soalan SPM 2018 K1 No 10

Maklumat berikut adalah merujuk kepada persamaan dua garis lurus, AB dan CD .

The following information refers to the equation of two straight lines, AB and CD .

$$AB: y - 2kx - 3 = 0$$

$$CD: \frac{x}{3h} + \frac{y}{4} = 1$$

dengan keadaan h dan k ialah pemalar
where h and k are constants

Diberi garis lurus AB dan garis lurus CD adalah berserenjang antara satu sama lain, ungkapkan h dalam sebutan k .

Given the straight lines AB and CD are perpendicular to each other, express h in terms of k .

Jawapan/Answer: [$h = \frac{8}{3}k$]

Soalan SPM 2018 K1 No 23

Rajah 10 menunjukkan kedudukan tiga tapak perkhemahan A , B dan C di sebahagian tebing sebatang sungai yang dilukis pada suatu satah Cartes, dengan keadaan A dan B terletak pada sebelah tebing sungai yang lurus.

Diagram 10 shows the position of three campsites A , B and C at a part of a riverbank drawn on a Cartesian plane, such that A and B lie on the same straight riverbank.

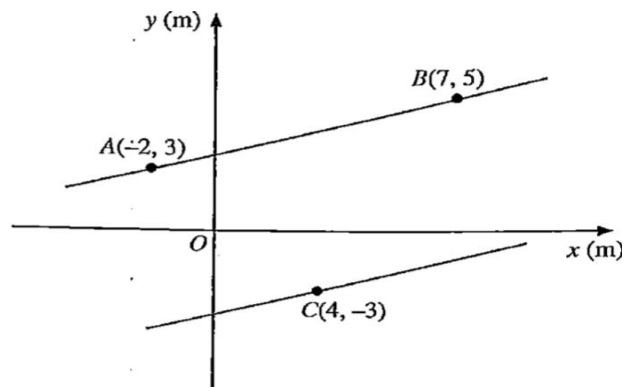
Diagram 10
Rajah 10

Shah hendak menyeberangi sungai tersebut dari tapak perkhemahan C ke tebing sungai bertentangan di mana terletak tapak perkhemahan A dan B . Cari jarak terdekat, dalam m, yang dia boleh lalui untuk menyeberangi sungai tersebut. Beri jawapan anda betul kepada empat tempat perpuluhan.

Shah wants to across the river from campsite C to the opposite riverbank where the campsites A and B are located. Find the shortest distance, in m, that he can take to cross the river. Give your answer correct to four decimal places.

Jawapan/Answer: [Jarak terdekat 7.1587m]

Soalan SPM 2018 K2 No 3

Penyelesaian secara lukisan berskala tidak diterima.

Solution to this question by scale drawing will not be accepted

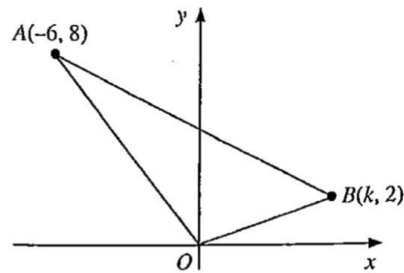

Diagram 1
Rajah 1

Rajah 1 menunjukkan segi tiga OAB .

Diagram 1 shows a triangle OAB .

- (a) Diberi luas segi tiga OAB ialah 30 unit^2 , find the value of k .
Given the area of triangle OAB is 30 unit^2 , find the value of k .
- (b) Titik $Q(2,4)$ terletak pada garis lurus AB .
Point $Q(2,4)$ lies on the straight line AB .
- (i) Cari $AQ:QB$
Find $AQ:QB$
- (ii) Titik P bergerak dengan keadaan $PB = 2PQ$. Cari persamaan lokus P .
Point P moves such that $PB = 2PQ$. Find the equation of the locus P .

Jawapan/Answer: [(a) $k = 6, k = -9$ (diabaikan) (b) $AQ:QB = 2:1$ (c) $3x^2 + 3y^2 - 4x - 28y + 40 = 0$]

Soalan SPM 2019 K1 No 13

Diberi bahawa $A(1,3)$ dan $B(4,7)$ berada pada suatu satah Cartes.

It is given that $A(1,3)$ and $B(4,7)$ lie on a Cartesian plane.

(a) Nyatakan jarak AB

State the distance AB

(b) Garis lurus AB dipanjangkan ke titik C dengan keadaan jaraknya dari titik B adalah dua kali jarak AB .

Cari koordinat C .

The straight line AB is extended to point C such that its distance from point B is twice the distance AB .

Find the coordinates of C .

Jawapan/Answer: [(a)5 unit (b) $C(10,15)$]

Soalan SPM 2019 K1 No 14

Rajah 5 menunjukkan tiga garis lurus, dengan keadaan k, p, q dan r ialah pemalar.

Diagram 5 shows three straight lines, such that k, p, q and r are constants.

Ungkapkan

Express

(a) k dalam sebutan q

k in terms of q

(b) r dalam sebutan k dan p

r in terms of k and p

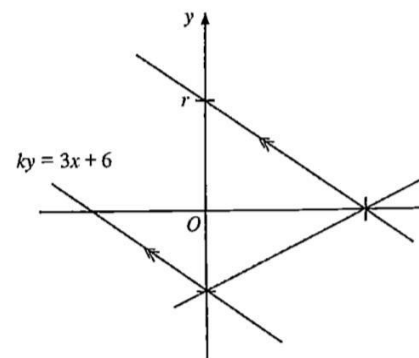

Diagram 5

Jawapan/Answer: [(a) $k = -\frac{6}{q}$ (b) $r = -\frac{3p}{k}$]

Soalan SPM 2019 K2 No 14

Penyelesaian secara lukisan berskala tidak diterima.

Solution to this question by scale drawing will not be accepted.

Rajah 5 menunjukkan laluan titik bergerak $P(x, y)$. P adalah sentiasa bergerak dengan jarak tetap dari titik A .

Diagram 5 shows the path of a moving point $P(x, y)$. P always moves at a constant distance from point A .

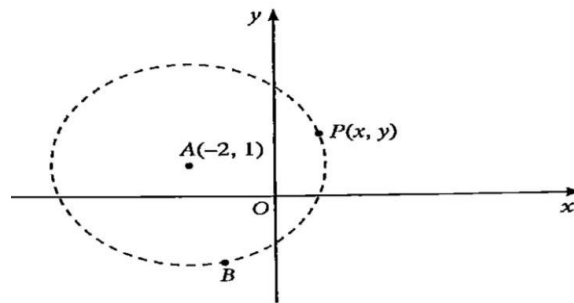

Diagram 5

$B(-1, -2)$ dan $R(-5, q)$ berada pada laluan titik P . Garis lurus BC ialah tangen kepada laluan itu dan bersilang dengan paksi- x pada titik C .

$B(-1, -2)$ and $R(-5, q)$ lie on path of point P . The straight line BC is a tangent to the path and intersects the x - axis at point C .

Cari

Find

- persamaan bagi laluan titik P
the equation of the path of point P
- nilai-nilai yang mungkin bagi q
the possible values of q
- luas ΔABC
the area of ΔABC

Jawapan/Answer: [(a) $x^2 + y^2 + 4x - 2y - 5 = 0$ (b) $q = 0, q = 2$ (c) 10 unit^2]

BAB 8: VECTOR

TOPIC;
Vector

SUB TOPIC:
The concept of vectors

L1 / 40 minutes

Note:

1. A vector quantity is a quantity that has both magnitude and direction.
2. Notations of vectors
 - i. \overrightarrow{AB} or \underline{a}
 - ii. \mathbf{AB} or \mathbf{a}
3. The magnitude of the vector \mathbf{AB} can be written as $|\mathbf{AB}| = |\mathbf{a}|$.

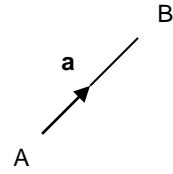

Example 1.

Diagram shows the vector \mathbf{u} and vector \mathbf{v} .
Construct the following vectors

- i. $2\mathbf{u}$
- ii. $-3\mathbf{u}$
- iii. $\mathbf{u} + \mathbf{v}$
- iv. $2\mathbf{u} - \mathbf{v}$
- v. $3\mathbf{v} - 2\mathbf{u}$

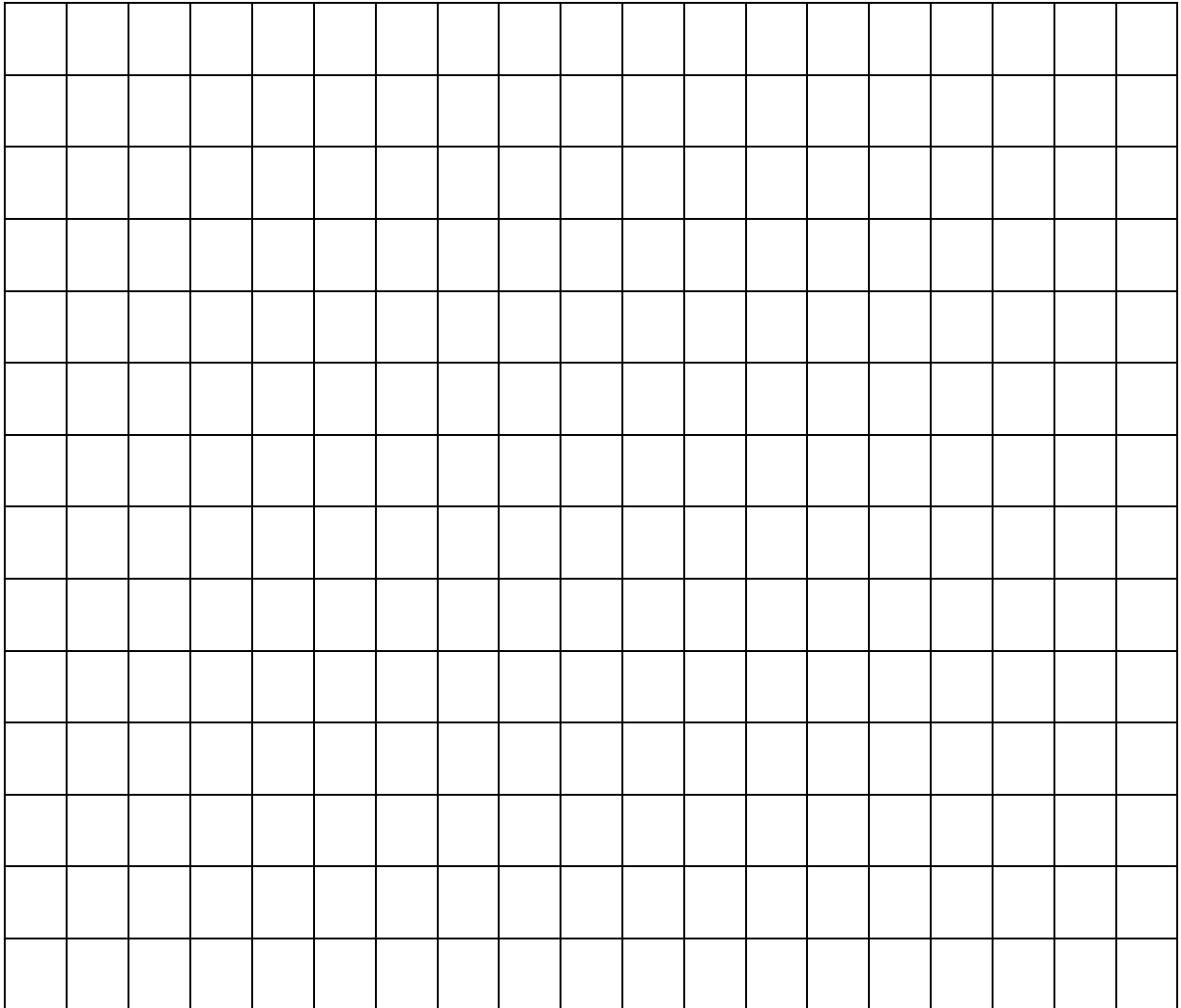
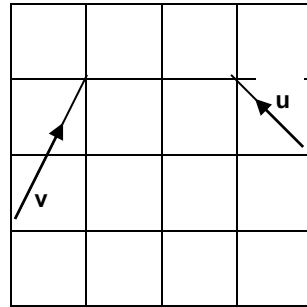

Example 2. Given that $|a| = 4$ and $|b| = 3$, find the numerical value of

- i. $|5a|$
- ii. $|-3a|$
- iii. $|4b| + |-2a|$

Example 3. Given that $|PQ| = 5$ and $|RS| = 2$, find the magnitude of

- i. QP
- ii. $3PQ$
- iii. $-4RS$

Example 4. Given $(k - 2) \mathbf{p} = (2m + 5) \mathbf{q}$, where \mathbf{p} and \mathbf{q} are non-parallel vector, find the numerical values of k and of m .

Exercise.

Note. Resultant Law

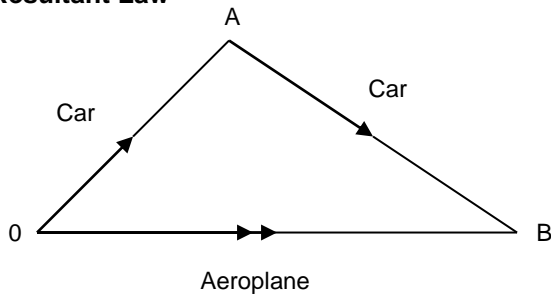

Car + Car = Aeroplane

$$\mathbf{OA} + \mathbf{AB} = \mathbf{OB}$$

or

$$\mathbf{AB} = \mathbf{OB} - \mathbf{OA}$$

Example 1.

Diagram shows a parallelogram PQRS.

Given that $\mathbf{PQ} = \mathbf{x}$ and $\mathbf{PS} = \mathbf{y}$.

G and H are mid points. Express in term of \mathbf{x} and/or \mathbf{y}

- i. **PR**
- ii. **PG**
- iii. **PH**
- iv. **GH**

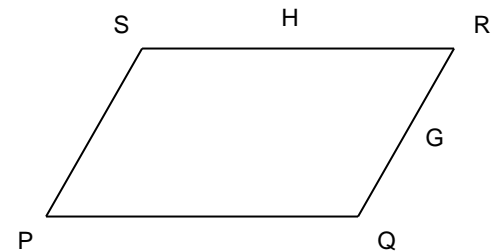
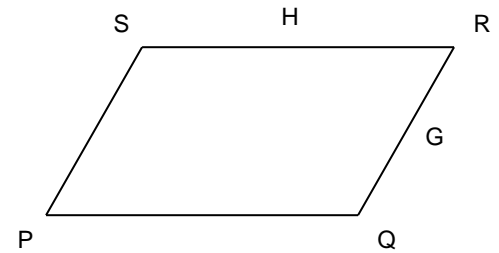

Example 2.

Diagram shows a triangle ABC.

Given that $\mathbf{AB} = 3\mathbf{x}$ and $\mathbf{AC} = 4\mathbf{y}$. Point Q lies on BC

such that $BQ = \frac{2}{3}BC$. Express in term of \mathbf{x} and/or \mathbf{y}

- i. \mathbf{BC}
- ii. \mathbf{BQ}
- iii. \mathbf{AQ}

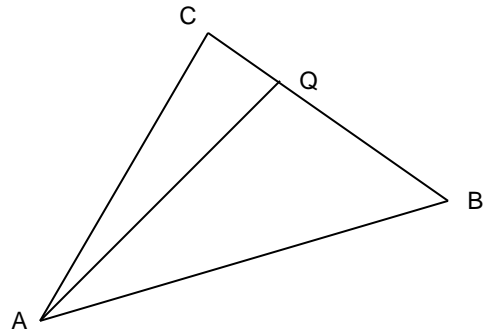
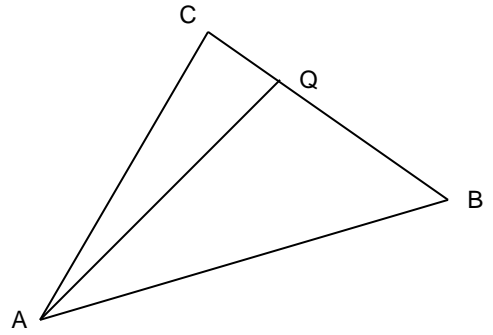

Exercise:

1. OAB is a triangle. Given that $\mathbf{OA} = 8\mathbf{x}$, $\mathbf{OB} = 6\mathbf{y}$, Q is midpoint of BA and $\mathbf{OA} = 4\mathbf{OP}$. Find in term of \mathbf{x} and/or \mathbf{y}

- i. \mathbf{BA}
- ii. \mathbf{BP}
- iii. \mathbf{OQ}

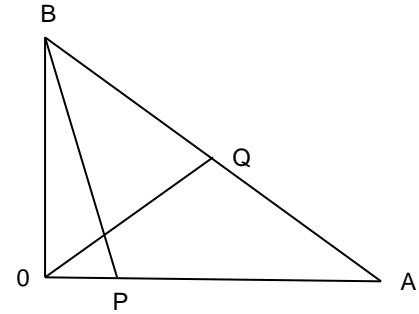

2. In triangle ABD, $\mathbf{AB} = \mathbf{x}$, $\mathbf{AP} = \mathbf{y}$, $\mathbf{AP} = \frac{1}{3}\mathbf{AD}$ and $\mathbf{BR} = \frac{1}{3}\mathbf{BD}$. Express in term of \mathbf{x} and/or \mathbf{y}

- i. \mathbf{DB}
- ii. \mathbf{AR}
- iii. \mathbf{BP}

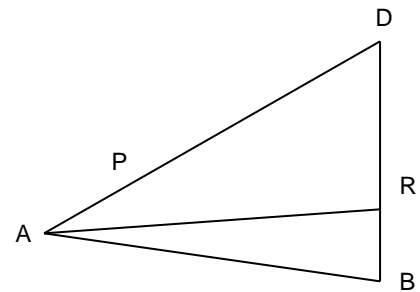

3. Diagram shows a triangle KLN. LMN and KFN are straight lines. Given that $\mathbf{LN} = 4\mathbf{LM}$, $\mathbf{KM} = 3\mathbf{EM}$, $\mathbf{KN} = 3\mathbf{KF}$, $\mathbf{LM} = \mathbf{x}$ and $\mathbf{LK} = \mathbf{y}$. Express in term of \mathbf{x} and/or \mathbf{y}

- i. \mathbf{KN}
- ii. \mathbf{KM}
- iii. \mathbf{LF}
- iv. \mathbf{LE}
- v. \mathbf{EN}

Hence, show that L, E and F collinear.

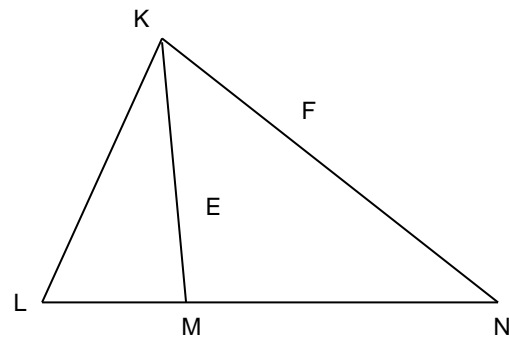

Example 1.

Diagram shows a triangle ABC. APB and BQC are straight line.
Given that $BQ : QC = 2 : 5$, $AP : AB = 1 : 4$, $\mathbf{AB} = 8\mathbf{x}$
and $\mathbf{AC} = 4\mathbf{y}$. Express in term of \mathbf{x} and/or \mathbf{y}

- i. \mathbf{BC}
- ii \mathbf{PQ}

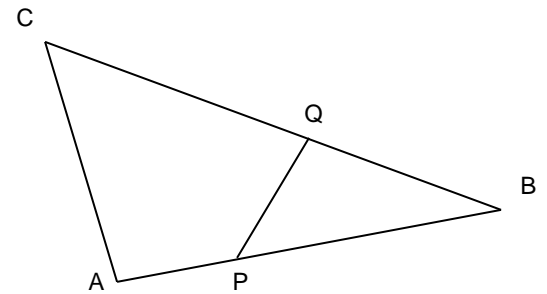
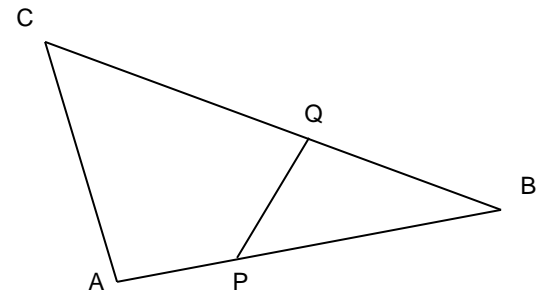

Exercise;

1. ABCD is a trapezium. Given that $AD = 6x$, $AB = 2y$, $BC = 5x$ and $AE : ED = 2 : 1$. Find in term of x and/or y

- a. **AC**
- b. **BD**
- c. **DC**
- d. **BE**
- e. **EC**

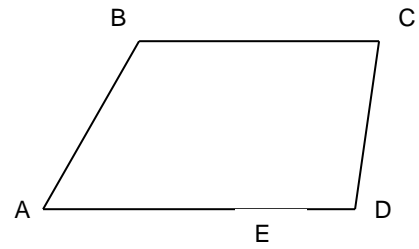

2. Diagram shows a triangle PQR. Given that $QT : TR = 3 : 1$, $PR = 4a$ and $PQ = 6b$. Express in term of a and/or b

- i. **QR**
- ii. **PT**

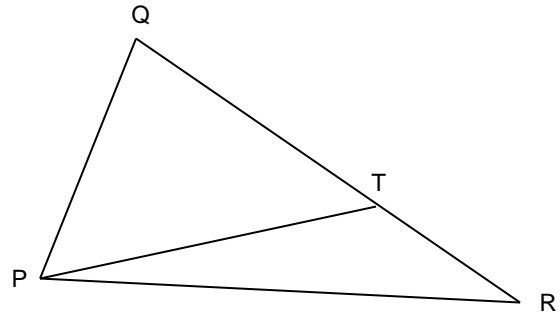

3. Diagram shows a parallelogram OABC. OPC and DCB are straight lines. Given that $OP : PC = 3 : 2$, $DB : CB = 5 : 3$, $OA = 6a$ and $OC = 10c$. Express in term of a and/or c

- i. **AC**
- ii. **AD**
- iii. **OD**
- iv. **AP**

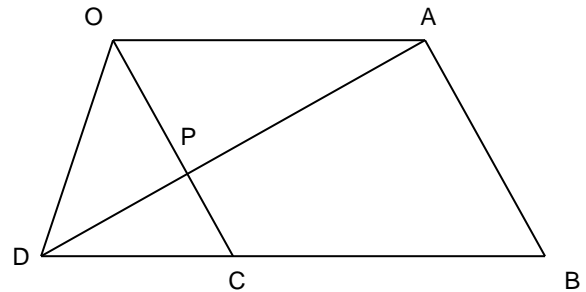

4. Diagram shows a quadrilateral ABCD. BPC is straight line. Given that $BC : PC = 3 : 1$, $AB = 5x$, $AD = 4y$ and $DC = x$. Express in term of x and/or y

- i. **BD**
- ii. **BC**
- iii. **AP**

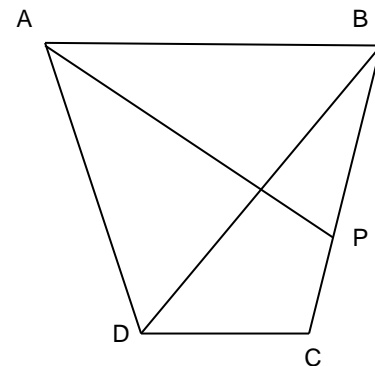

Note;

Given $P(x, y)$ and $Q(r, s)$, therefore

1. $\mathbf{OP} = \begin{pmatrix} x \\ y \end{pmatrix}$ or $x\mathbf{i} + y\mathbf{j}$

2. $\mathbf{OQ} = \begin{pmatrix} r \\ s \end{pmatrix}$ or $r\mathbf{i} + s\mathbf{j}$

3. $\mathbf{PQ} = \mathbf{OQ} - \mathbf{OP}$
 $= \begin{pmatrix} x \\ y \end{pmatrix} - \begin{pmatrix} r \\ s \end{pmatrix} = \begin{pmatrix} x-r \\ y-s \end{pmatrix}$

4. $|\overrightarrow{OP}| = \sqrt{x^2 + y^2}$ and $|\overrightarrow{OQ}| = \sqrt{r^2 + s^2}$

5. Unit Vector in the direction of $\mathbf{PQ} = \frac{1}{|\overrightarrow{PQ}|} \overrightarrow{PQ}$

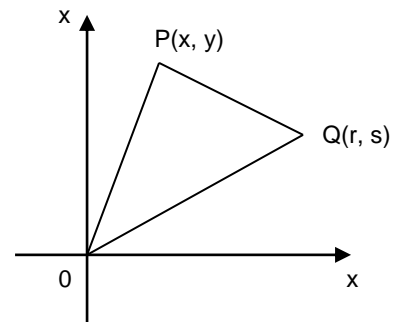

Example 1. Given $P(2, -3)$ and $Q(4, 6)$. Find, in term of $x\mathbf{i} + y\mathbf{j}$

- i. \mathbf{OP} and \mathbf{OQ}
- ii. \mathbf{PQ}
- iii. $|\overrightarrow{PQ}|$
- iv. unit vector in the direction of \mathbf{PQ}

Example 2. Given $\mathbf{a} = 2\mathbf{i} + 5\mathbf{j}$, $\mathbf{b} = 3\mathbf{i} - 4\mathbf{j}$ and $\mathbf{c} = -\mathbf{i} + 7\mathbf{j}$. Find

- i. $\mathbf{a} + 2\mathbf{b}$
- ii. $\mathbf{c} - 3\mathbf{a}$
- iii. $|\mathbf{c}|$
- iv. $|\mathbf{a} + 2\mathbf{b}|$
- v. unit vector in the direction of $\mathbf{a} + 2\mathbf{b}$

Example 3. It is given that vector $\mathbf{x} = \begin{pmatrix} 7 \\ 3 \end{pmatrix}$ and vector $\mathbf{y} = \begin{pmatrix} -2 \\ k \end{pmatrix}$, where k is a constant.

- i. Express, in term of k , the vector $\mathbf{x} + \mathbf{y}$.
- ii. Given that $|\mathbf{x} + \mathbf{y}| = 13$ units, find the values of k
- iii. By using $k > 0$, state the unit vector in the direction of $\mathbf{x} + \mathbf{y}$

Exercise.

Note;

1. If $\mathbf{PQ} = n \mathbf{RS}$, then PQ is parallel to RS
2. Given $\mathbf{PQ} = ax + by$ and $\mathbf{RS} = mx + ny$. If PQ is parallel to RS
then $\frac{m}{a} = \frac{n}{b}$ or $\frac{m}{n} = \frac{a}{b}$

Example 1. Given that $\mathbf{AB} = x - 3y$ and $\mathbf{CD} = 4x - 12y$. Prove that \mathbf{AB} is parallel to \mathbf{CD}

Example 2. Given that $\mathbf{PQ} = 2\mathbf{a} + 5\mathbf{b}$ and $\mathbf{RS} = -\frac{4}{3}\mathbf{a} - \frac{10}{3}\mathbf{b}$. Prove that \mathbf{PQ} is parallel to \mathbf{RS}

Example 3. Given that the vector $\mathbf{MN} = 2\mathbf{a} - 3\mathbf{b}$ and the vector $\mathbf{TU} = (h + 2)\mathbf{a} + 7\mathbf{b}$. If \mathbf{MN} is parallel to \mathbf{TU} , find the value of h.

Example 4. Given $(2 + m)\mathbf{a} = (3m - n + 1)\mathbf{b}$, where \mathbf{a} and \mathbf{b} are non-parallel vector, find the numerical values of m and of n .

Example 5. Given $\mathbf{u} = \begin{pmatrix} 7 \\ 9 \end{pmatrix}$ and $\mathbf{v} = \begin{pmatrix} p-1 \\ 3 \end{pmatrix}$. Find the values of p if

- \mathbf{u} is parallel to \mathbf{v}
- $|\mathbf{u}| = |\mathbf{v}|$

Exercise.

Note;

1. If $\mathbf{PQ} = k \mathbf{PR}$ or $\mathbf{PQ} = h \mathbf{QR}$ or $\mathbf{PR} = m \mathbf{QR}$ then P, Q and R are collinear
2. Given $\mathbf{PQ} = ax + by$ and $\mathbf{QR} = mx + ny$. If P, Q and R are collinear
then $\frac{m}{a} = \frac{n}{b}$ or $\frac{m}{n} = \frac{a}{b}$

Example 1. The vector \mathbf{a} and \mathbf{b} are non zero and non parallel. It is given that $(m + 2)\mathbf{a} = (5 - n)\mathbf{b}$. Find the value of m and of n.

Example 2. Given that $\mathbf{PQ} = 2\mathbf{x} + 5\mathbf{y}$ and $\mathbf{PR} = 6\mathbf{x} + 15\mathbf{y}$. Prove that P, Q and R are collinear

Example 3. Given that $\mathbf{PQ} = 3\mathbf{i} + 5\mathbf{j}$ and $\mathbf{QR} = 8\mathbf{i} + (1 + k)\mathbf{j}$. If P, Q and R are collinear, find the value of k.

Example 4. It is given OABC is a parallelogram such that vector $\mathbf{OA} = \begin{pmatrix} 3 \\ 4 \end{pmatrix}$ and vector $\mathbf{OC} = \begin{pmatrix} 12 \\ 5 \end{pmatrix}$

a. Find, in form of $\begin{pmatrix} x \\ y \end{pmatrix}$, vector \mathbf{OB}

b. If R is a point such that vector $\mathbf{CR} = \begin{pmatrix} -3 \\ 7 \end{pmatrix}$, find the vector \mathbf{OR} . Hence, determine whether O, A and R are collinear.

Exercise.

1. The vector \underline{a} and \underline{b} are non-zero and non-parallel. It is given that $(h + 3)\underline{a} = (k - 5)\underline{b}$, where h and k are constants. Find the value of

- a. h
b. k

SPM 2008 / (2 marks)

2. Given that $\overrightarrow{OP} = i + j$ and $\overrightarrow{OQ} = 3i - 2j$. Find the value of k if $4k\overrightarrow{OP} + \overrightarrow{OQ}$ is parallel to the y -axis.

SBP 2012 / (3 marks)

3. The points P , Q and R are collinear. It is given that $\overrightarrow{PQ} = 4\underline{a} - 2\underline{b}$ and $\overrightarrow{QR} = 3\underline{a} + (1 + k)\underline{b}$, where k is a constant. Find

- a. the value of k
b. the ratio of $PQ : QR$

SPM 2006 / (4 marks)

4. The following information refers to the vector \underline{a} and \underline{b}

$$\underline{a} = \begin{bmatrix} 6 \\ m - 4 \end{bmatrix}, \quad \underline{b} = \begin{bmatrix} 2 \\ 5 \end{bmatrix}$$

It is given that $\underline{a} = k\underline{b}$, where \underline{a} is parallel to \underline{b} and k is a constant. Find the value of

- a. k
b. m

SPM 2012 / (3 marks)

5. Given $\underline{u} = \begin{pmatrix} 3 \\ 4 \end{pmatrix}$ and $\underline{v} = \begin{pmatrix} 6 \\ k - 1 \end{pmatrix}$, find

- a. the unit vector in the direction of \underline{u} .
b. the value of k such that \underline{u} and \underline{v} are parallel.

SPM 2012 / (4 marks)

6. Given that $\mathbf{r} = (k - 1)\mathbf{i} + 3\mathbf{j}$ and $\mathbf{s} = -4\mathbf{i} + (k - 9)\mathbf{j}$. If \mathbf{r} is parallel to \mathbf{s} , find the values of

- a. k
b. $|\mathbf{r} - \mathbf{s}|$

7. Given that $\mathbf{x} = 2\mathbf{i} - \mathbf{j}$ and $\mathbf{y} = -\mathbf{i} + 3\mathbf{j}$. Find the value of p if $3p\mathbf{x} + 3\mathbf{y}$ is parallel to the y -axis.

8. Given that $\mathbf{PQ} = m\mathbf{i} + 8\mathbf{j}$ and $\mathbf{RQ} = 18\mathbf{i} - 4\mathbf{j}$. Find the value of m if

- a. $|\mathbf{PR}| = 20$
b. P, Q, R are collinear

Example 1.

Diagram shows that ABCD is a quadrilateral, AED and EFC are straight lines. It is given that $\mathbf{AB} = 20\mathbf{x}$, $\mathbf{AE} = 8\mathbf{y}$,

$\mathbf{DC} = 25\mathbf{x} - 24\mathbf{y}$, $\mathbf{AE} = \frac{1}{4}\mathbf{AD}$, and $\mathbf{EF} = \frac{3}{5}\mathbf{EC}$

- i. Express, in term of \mathbf{x} and/or \mathbf{y} , \mathbf{BD} and \mathbf{EC}
- ii. Show that, point B, F and D are collinear.

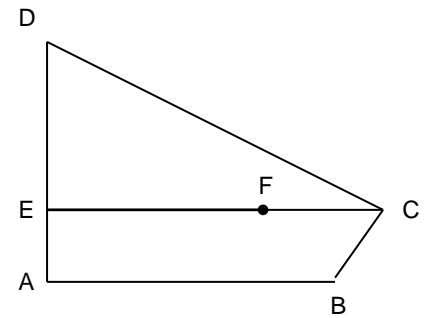
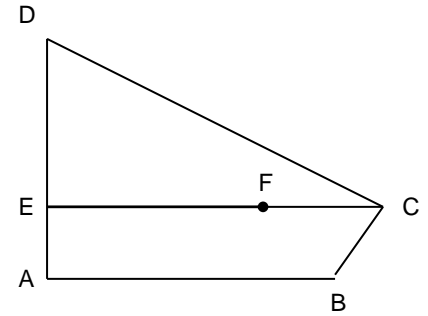

Example 2.

Diagram shows a parallelogram ABCD. Point P on the straight line AB and point Q lies on the straight line DC. The straight line AQ is extended to the point R such that $AQ = 2QR$. It is given that

$AP : PB = 3 : 1$, $DQ : QC = 3 : 1$, $\vec{AP} = 9\mathbf{u}$ and $\vec{AD} = 2\mathbf{v}$.

Express, in term of \mathbf{u} and \mathbf{v}

- i. **AQ**
- ii. **PC**
- iii. **AR**
- iv. **PR**

Hence, show that the points P, C and R are collinear

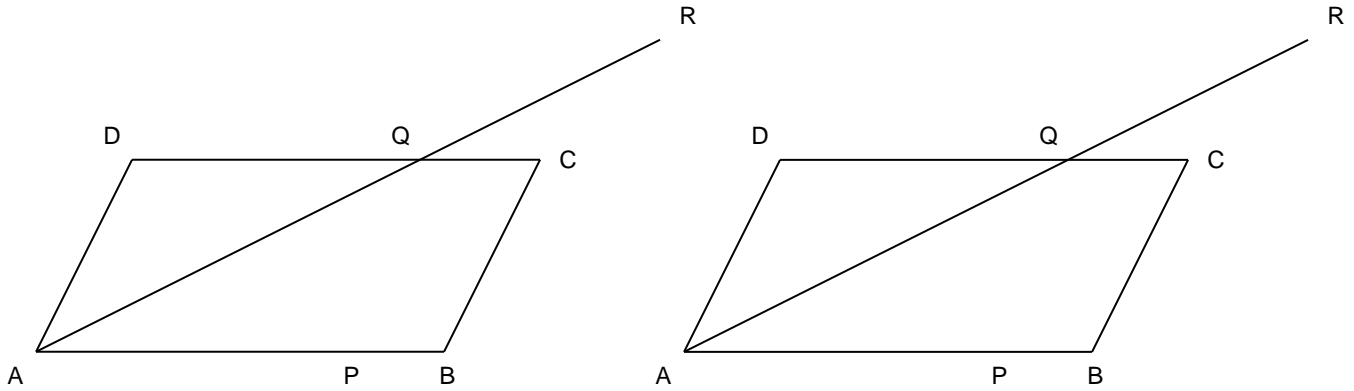

Exercise

Example 1.

Diagram shows the point $P(3, 5)$ and point $Q(7, -2)$.

- a. Express, in the form of $xi + yj$
 - i. **OP**
 - ii. **QP**
- b. Find the unit vector in the direction of **QP**

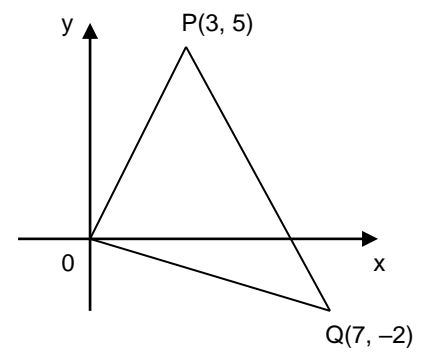
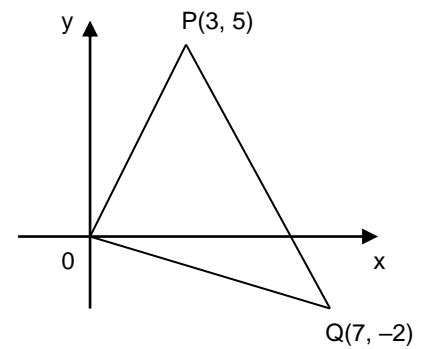

Example 2.

Diagram shows a parallelogram OABC drawn on a Cartesian plane.

It is given that $\vec{OA} = 4\mathbf{i} + 3\mathbf{j}$ and $\vec{AB} = -6\mathbf{i} + 4\mathbf{j}$.

- a. Find, in form of $\begin{pmatrix} x \\ y \end{pmatrix}$
- \vec{OB}
 - \vec{AC}
- b. Find the unit vector in the direction of \vec{AC}

SPM 2011 (3 marks)

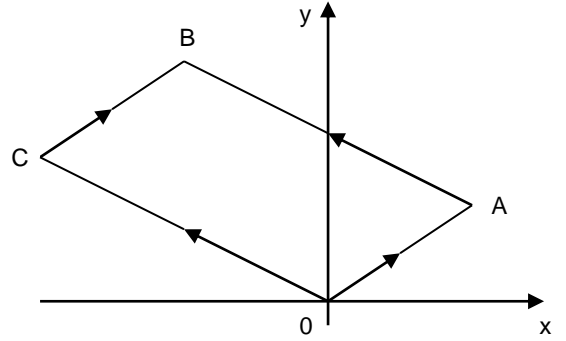
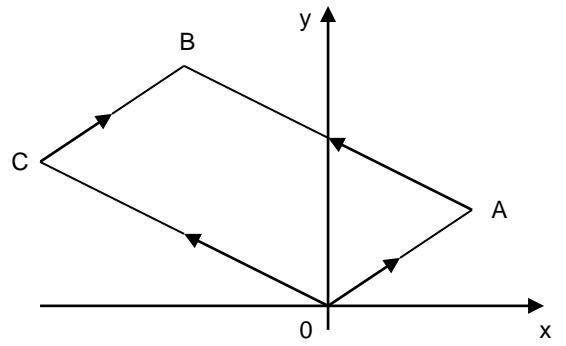

Exercise.

Example 1.

Diagram shows a triangle OPQ. The point R lie on OP and the point S lie on PQ.
It is given that $\mathbf{OP} = \mathbf{u}$, $\mathbf{OQ} = \mathbf{v}$, $3\mathbf{OR} = 2\mathbf{OP}$ and $\mathbf{PQ} = 2\mathbf{PS}$.

- a. Express the following vectors in term of \mathbf{u} and \mathbf{v} .
 - i. \mathbf{QR}
 - ii. \mathbf{OS}

- b. It is given that $\mathbf{OT} = m \mathbf{OS}$ and $\mathbf{QT} = n \mathbf{QR}$, where m and n are constants.
Express \mathbf{OT} , in term of
 - i. m , \mathbf{u} and \mathbf{v}
 - ii. n , \mathbf{u} and \mathbf{v} .

- c. Hence, find the value of m and of n.

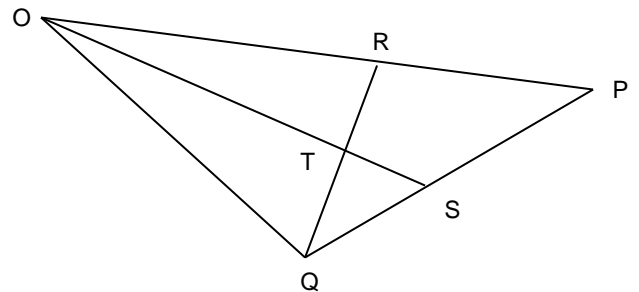
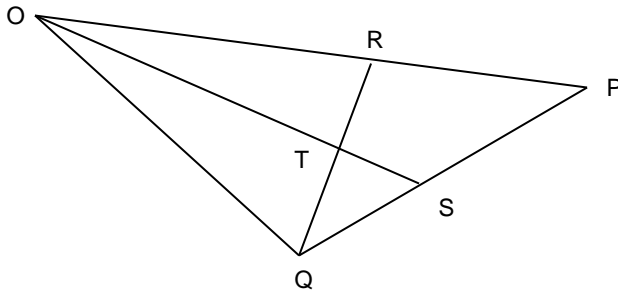

Exercise.

BAB 9 : PENYELESAIAN SEGITIGA / SOLUTIONS OF TRIANGLE

9.1 PETUA SINUS / SINE RULES

Bagi sebarang segitiga ABC / For any triangle ABC

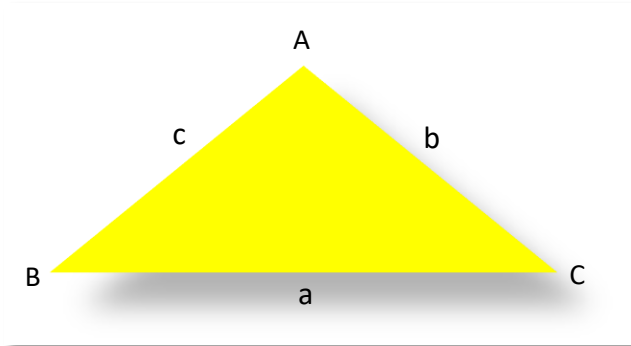

Smart TIPS

In order to solve a triangle by using the sine rule, the following conditions must be learnt:

- (a) Two angles and length of one side, or
- (b) The lengths of two sides and a non-included angle.

TIP PINTAR

Untuk menyelesaikan segitiga menggunakan petua sinus, syarat berikut perlu diketahui terlebih dahulu:

- (a) Dua sudut dan satu panjang sisi, atau
- (b) Dua panjang sisi dan satu sudut bukan kandung.

$$\frac{a}{\sin A} = \frac{b}{\sin B} = \frac{c}{\sin C}$$

Untuk mencari panjang sisi: Untuk mencari sudut :

To find unknown sides :

$$\frac{a}{\sin A} = \frac{b}{\sin B} = \frac{c}{\sin C}$$

To find unknown angles :

$$\frac{\sin A}{a} = \frac{\sin B}{b} = \frac{\sin C}{c}$$

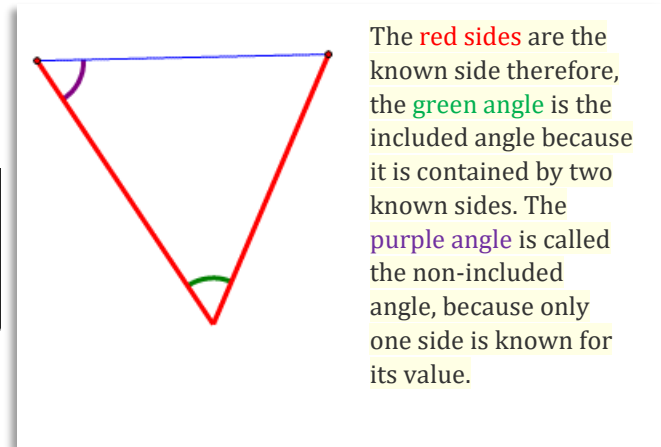

Menyelesaikan segi tiga melibatkan petua sinus.

Solving triangles involving sine rules.

Tugasan 1 : Cari panjang sisi segitiga yang tidak diketahui apabila dua sudut dan satu panjang sisi diketahui.

Task 1 : Find the unknown sides of a triangle when two of its angles and one of the corresponding sides are known.

Contoh 1 / Example 1

1)

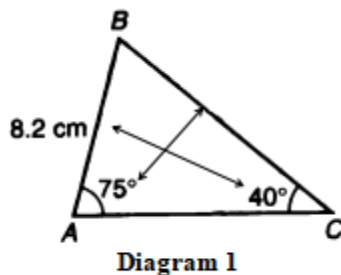

Penyelesaian / Solution :

$$\frac{BC}{\sin 75^\circ} = \frac{8.2}{\sin 40^\circ}$$

$$BC = \frac{8.2}{\sin 40^\circ} \times \sin 75^\circ$$

Dengan menggunakan kalkulator saintifik,
Using the scientific calculator,

$$BC = 12.32 \text{ cm}$$

Rajah 1 menunjukkan segitiga ABC. Hitung panjang BC

Diagram 1 shows the triangle ABC. Calculate the length of BC.

(2)

Penyelesaian / Solution :

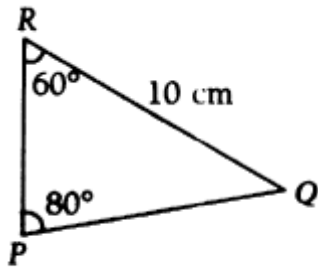

Diagram 2

Rajah 2 menunjukkan segitiga PQR. Hitung panjang PQ.

Diagram 2 shows the triangle PQR. Calculate the length of PQ.

[8.794 cm]

(3)

Penyelesaian / Solution :

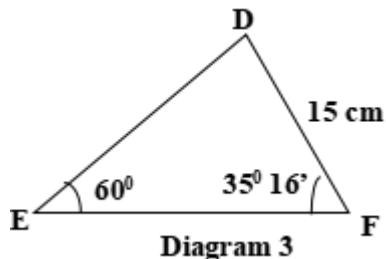

Diagram 3

Rajah 3 menunjukkan segitiga DEF. Hitung panjang DE.

Diagram 3 shows the triangle DEF. Calculate the length of DE.

[10.00 cm]

(4)

Penyelesaian / Solution :

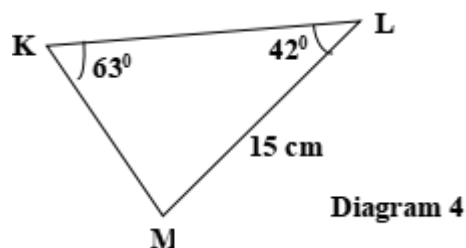

Diagram 4

Rajah 4 menunjukkan segitiga KLM. Hitung panjang KM.

Diagram 4 shows the triangle KLM. Calculate the length of KM.

[11.26 cm]

(5)

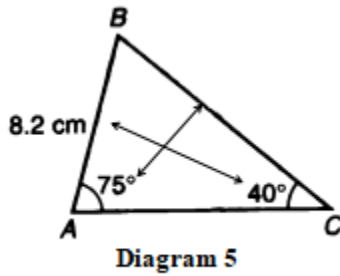

Rajah 5 menunjukkan segitiga ABC. Hitung panjang AC.

Diagram 5 shows the triangle ABC. Calculate the length of AC.

Penyelesaian / Solution :

$$\angle ABC = 180^\circ - 40^\circ - 75^\circ = 65^\circ$$

$$\frac{AC}{\sin 65^\circ} = \frac{8.2}{\sin 40^\circ}$$

$$AC = \frac{8.2}{\sin 40^\circ} \times \sin 65^\circ$$

Dengan menggunakan kalkulator saintifik, Using the scientific calculator,

$$AC = 11.56 \text{ cm}$$

(6)

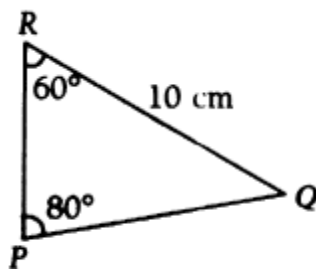

Rajah 6 menunjukkan segitiga PQR. Hitung panjang PR.

Diagram 6 shows the triangle PQR. Calculate the length of PR.

Penyelesaian / Solution :

[6.527 cm]

(7)

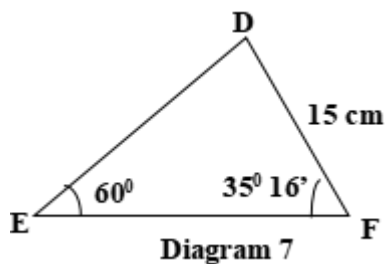

Rajah 7 menunjukkan segitiga DEF. Hitung panjang EF.

Diagram 7 shows the triangle DEF. Calculate the length of EF.

Penyelesaian / Solution :

[17.25 cm]

(8)

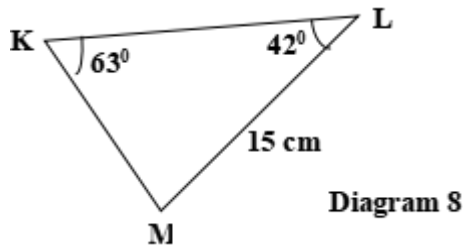

Penyelesaian / Solution :

Rajah 8 menunjukkan segitiga KLM. Hitung panjang KL

Diagram 8 shows the triangle KLM. Calculate the length of KL

[16.26 cm]

Tugasan 2: Cari panjang sisi segitiga yang tidak diketahui apabila 2 sudut dan satu sisi diketahui.

Task 2 : Find the unknown sides of a triangle when two of its angles and the side not corresponding to the angles are known.

(9)

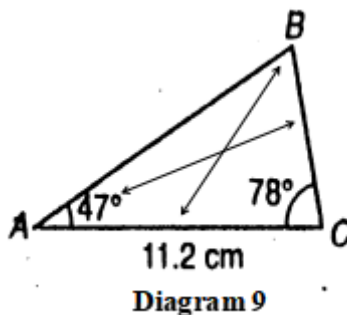

Penyelesaian / Solution :

$$\begin{aligned}\angle ABC &= 180^\circ - 47^\circ - 78^\circ = 55^\circ \\ \frac{BC}{\sin 47^\circ} &= \frac{11.2}{\sin 55^\circ} \\ BC &= \frac{11.2}{\sin 55^\circ} \times \sin 47^\circ\end{aligned}$$

Rajah 9 menunjukkan segitiga ABC. Hitung panjang BC

Dengan menggunakan kalkulator saintifik, Using scientific calculator,

$$BC = 9.9996 \text{ cm or } 10.00 \text{ cm}$$

Diagram 9 shows the triangle ABC. Calculate the length of BC.

(10)

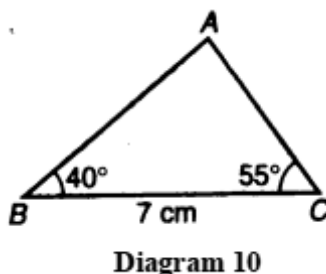

Penyelesaian / Solution :

Rajah 10 menunjukkan segitiga ABC. Hitung panjang AC.

Diagram 10 shows the triangle ABC. Calculate the length of AC.

[4.517 cm]

(11)

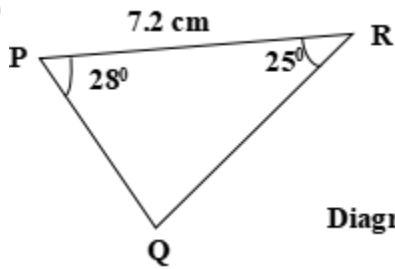

Diagram 11

Rajah 11 menunjukkan segitiga PQR. Hitung panjang PQ.

Diagram 11 shows the triangle PQR. Calculate the length of PQ.

Penyelesaian / Solution :

[3.810 cm]

(12)

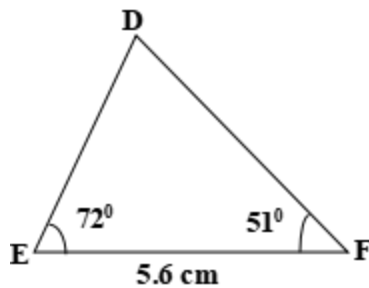

Diagram 12

Rajah 12 menunjukkan segitiga DEF. Hitung panjang DE.

Diagram 12 shows the triangle DEF. Calculate the length of DE.

Penyelesaian / Solution :

[5.189 cm]

Tugasan 3 : Cari sudut yang tidak diketahui dalam sebuah segitiga apabila dua sisi dan satu sudut bukan kandung diberi.

Task 3 : Find the unknown angles of a triangle when two sides and a non-included angle are given.

(1)

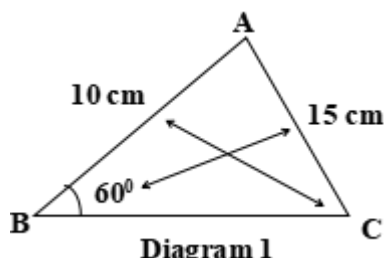

Diagram 1

Rajah 1 menunjukkan segitiga ABC. Cari $\angle ACB$.
Diagram 1 shows the triangle ABC. Find $\angle ACB$.

Penyelesaian / Solution :

$$\frac{\sin C}{10} = \frac{\sin 60^\circ}{15}$$

$$\sin C = \frac{10 \sin 60^\circ}{15}$$

$$\sin C = 0.5774$$

$$C = \sin^{-1} 0.5774$$

$$C = 35.27^\circ$$

(2)

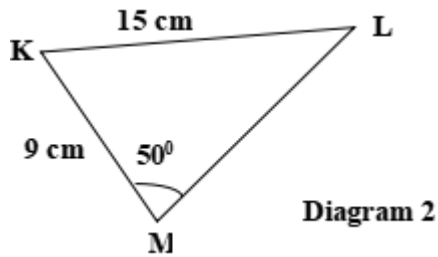

Penyelesaian / Solution :

Rajah 2 menunjukkan segitiga KLM. Cari $\angle KLM$.

Diagram 2 shows the triangle KLM . Find $\angle KLM$

[27.36 $^\circ$]

(3)

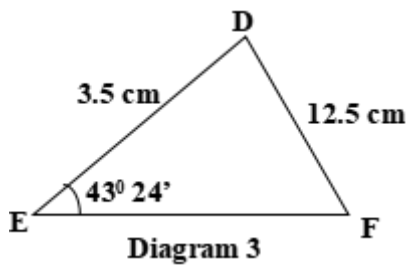

Penyelesaian / Solution :

Rajah 3 menunjukkan segitiga DEF. Cari $\angle DFE$.

Diagram 3 shows the triangle DEF. Find $\angle DFE$.

[11.09 $^\circ$]

(4)

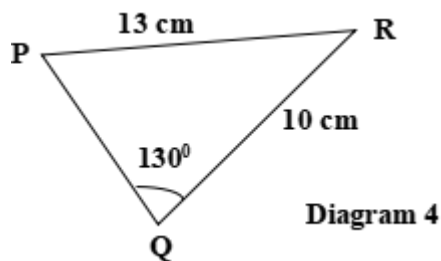

Penyelesaian / Solution :

Rajah 4 menunjukkan segitiga PQR. Cari $\angle QPR$.

Diagram 4 shows the triangle PQR. Find $\angle QPR$.

[36.11 $^\circ$]

(5)

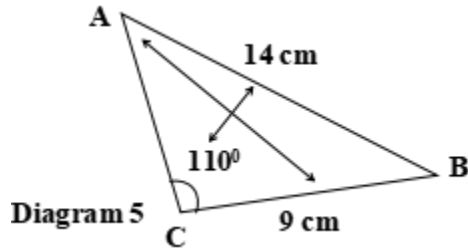

Rajah 5 menunjukkan segitiga ABC. Cari $\angle ABC$.
Diagram 5 shows the triangle ABC. Find $\angle ABC$.

Penyelesaian / Solution :

$$\frac{\sin A}{9} = \frac{\sin 110^\circ}{14}$$

$$\sin A = \frac{9 \sin 110^\circ}{14}$$

$$\sin A = 0.6041$$

$$A = \sin^{-1} 0.6041$$

$$A = 37.16^\circ$$

$$\angle ABC = 180^\circ - 110^\circ - 37.16^\circ$$

$$= 32.84^\circ$$

(6)

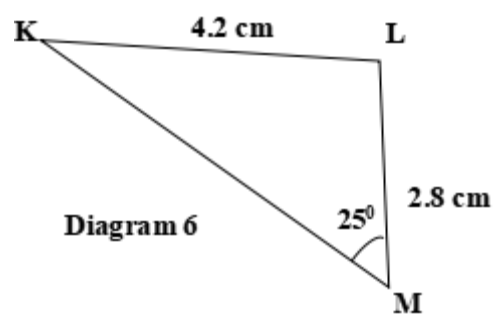

Rajah 6 menunjukkan segitiga KLM. Cari $\angle KLM$.
Diagram 6 shows the triangle KLM. Find $\angle KLM$.

Penyelesaian / Solution :

[138.64°]

(7)

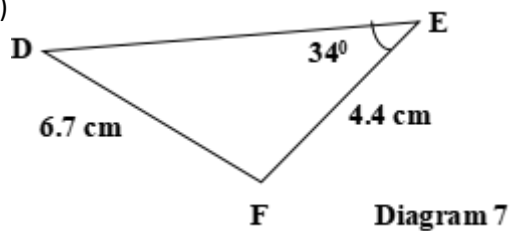

Rajah 7 menunjukkan segitiga DEF. Cari $\angle DFE$.
Diagram 7 shows the triangle DEF. Find $\angle DFE$.

Penyelesaian / Solution :

[124.46°]

(8)

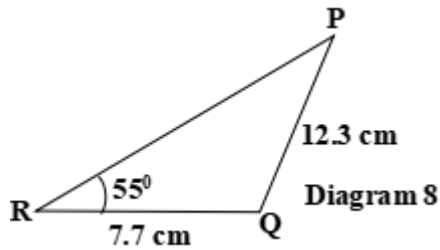

Penyelesaian / Solution :

Rajah 8 menunjukkan segitiga PQR. Cari $\angle PQR$.

Diagram 8 shows the triangle PQR. Find $\angle PQR$.

[94.15°]

Tugasan 4 : Cari panjang sisi yang tidak diketahui bagi segitiga berikut apabila 2 sisi dan satu sudut bukan kandung diberi.

Task 4 : Find the unknown side of a triangle when two sides and a non-included angle are given.

(1)

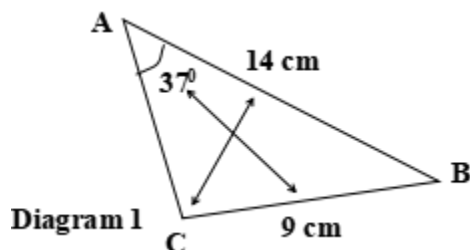

Rajah 1 menunjukkan segitiga ABC. Diberi sudut $\angle ACB$ adalah sudut cakah, cari panjang sisi AC.

Diagram 1 shows the triangle ABC. Given that $\angle ACB$ is an obtuse angle, find the length of AC.

Penyelesaian / Solution :

$$\frac{\sin C}{14} = \frac{\sin 37^\circ}{9}$$

$$\sin C = \frac{14 \sin 37^\circ}{9}$$

$$\sin C = 0.9362$$

$$C = \sin^{-1} 0.9362$$

$$C = 110.58^\circ$$

$$B = 180^\circ - 110.58^\circ - 37^\circ$$

$$= 32.42^\circ$$

$$\frac{AC}{\sin 32.42^\circ} = \frac{9}{\sin 37^\circ}$$

$$AC = \frac{9 \sin 32.42^\circ}{\sin 37^\circ}$$

$$AC = 8.018 \text{ cm}$$

(2)

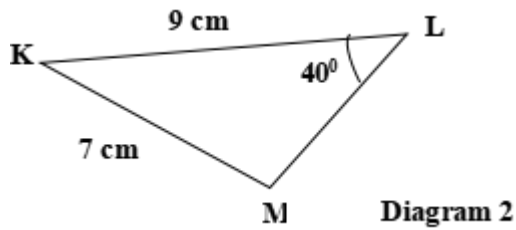

Penyelesaian / Solution :

Rajah 2 menunjukkan segitiga KLM. Diberi bahawa $\angle KLM$ ialah sudut cakah, cari panjang ML.

Diagram 2 shows the triangle KLM. Given that $\angle KLM$ is an obtuse angle, find the length of ML.

[2.952 cm]

(3)

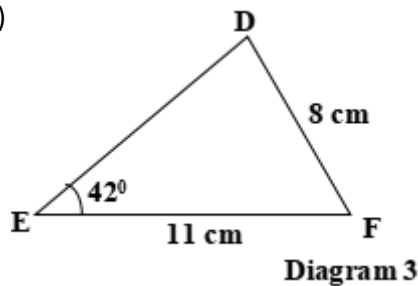

Penyelesaian / Solution :

Rajah 3 menunjukkan segitiga DEF. Diberi nilai $\angle EDF$ adalah lebih besar daripada 90° , cari panjang DE.

Diagram 3 shows the triangle DEF. Given that the value of $\angle EDF$ is greater than 90° , find the length of DE.

[5.040 cm]

(4)

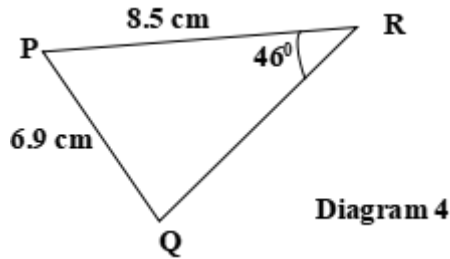

Penyelesaian / Solution :

Rajah 4 menunjukkan segitiga PQR. Diberi bahawa $\angle PQR$ ialah sudut dalam sukuan kedua pada satah Cartesian, cari panjang QR.

Diagram 4 shows the triangle PQR. Given that $\angle PQR$ is an angle in the second quadrant of the cartesian plane, find the length of QR.

[2.707 cm]

(5)

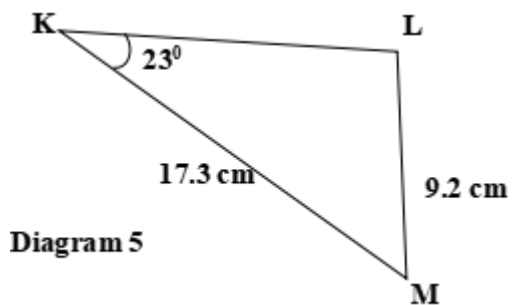

Penyelesaian / Solution :

Rajah 5 menunjukkan segitiga KLM. Diberi bahawa $\angle KLM$ ialah sudut pada sukuan kedua dalam satah Cartesian, cari panjang KL.

Diagram 5 shows the triangle KLM. Given that $\angle KLM$ is an angle in the second quadrant of the cartesian plane, find the length of KL

[9.686 cm]

Menyelesaikan masalah berkaitan segitiga menggunakan petua sinus.

Solving problem related to triangles using the sine rule.

1. Encik Samad membuat pelan bagi kawasan tanaman sayur-sayuran miliknya seperti dalam rajah. Encik Samad ingin meletakkan dua penyiram air di tengah-tengah kawasan tanaman. Pili yang akan mengawal penyiram air itu diletakkan di bucu kawasan tanaman. Jarak di antara dua penyiram air ialah 6 m dan jarak di antara pili air dengan penyiram air yang paling dekat ialah 5 m. Sudut yang terbentuk antara pili dengan kedua-dua penyiram air itu ialah 25° . Hitung jarak di antara pili dengan penyiram air yang paling jauh.



1. Encik Samad makes a plan for his vegetable farm as shown in the diagram. Encik Samad wants to install two water sprinklers in the middle of the farm. The water tap which controls the water sprinklers is installed at one corner of the farm. The distance between the two water sprinklers is 6 m and the distance between the water tap and the nearest water sprinkler is 5 m. The angle formed between the tap and both water sprinklers is 25° . Calculate the distance between the tap and the furthest water sprinkler.



Penyelesaian / Solution :

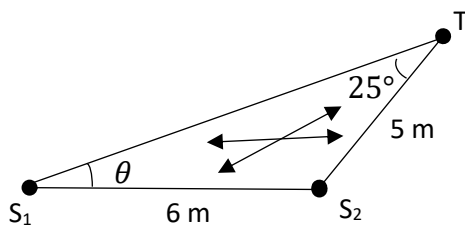

$$\frac{\sin \theta}{5} = \frac{\sin 25^\circ}{6}$$

$$\sin \theta = \frac{5 \times \sin 25^\circ}{6}$$

$$\sin \theta = 0.3522$$

$$\theta = \sin^{-1} 0.3522$$

$$\theta = 20.62^\circ$$

$$\angle TS_2S_1 = 180 - 25 - 20.62 = 134.38^\circ$$

$$\frac{TS_1}{\sin 134.38^\circ} = \frac{6}{\sin 25^\circ}$$

$$TS_1 = \frac{6 \times \sin 134.38^\circ}{\sin 25^\circ}$$

$$\therefore TS_1 = 10.147$$

[10.147 m]

2. Sekumpulan ahli pengakap mengadakan aktiviti merentas sungai semasa kem jati diri. Mereka memasang tali dari pokok P ke pokok Q dan pokok R di seberang sungai seperti dalam rajah. Jarak di antara pokok Q dengan pokok R ialah 80 m dan sudut yang terbentuk antara pokok Q dengan pokok R di P ialah 50° . Cari nilai x , iaitu jarak dari pokok P ke pokok Q .

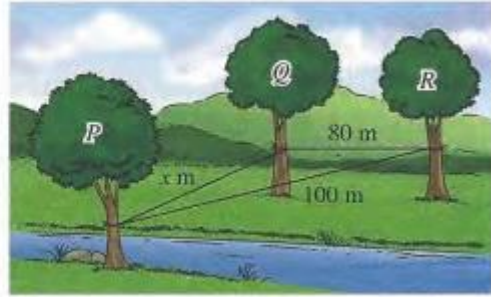

2. A group of scouts organised an activity on crossing a river during a motivational camp. They tied a rope from tree P to tree Q and tree R on the other side of the river as shown in the diagram. The distance between tree Q and tree R is 80 m and a 50° angle is formed between tree Q and tree R at P . Find the value of x , the distance from tree P to tree Q .

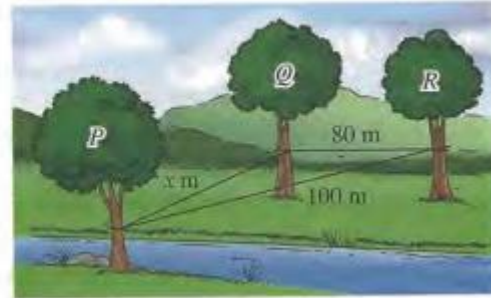

Penyelesaian / *Solution* :

3.

Rajah di sebelah menunjukkan segi tiga ABD . Titik C dan titik E terletak di atas garis lurus AD .

- Cari panjang BE , CE dan DE .
- Hitung $\angle EAB$, $\angle BCE$, $\angle BCD$, $\angle ABD$ dan $\angle CBD$.
- Huraikan kes berambiguiti dalam rajah di sebelah.

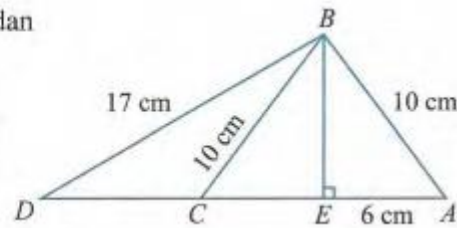

The diagram on the right shows a triangle ABD . Point C and point E lie on the straight line AD .

- Find the lengths of BE , CE and DE .
- Calculate $\angle EAB$, $\angle BCE$, $\angle BCD$, $\angle ABD$ and $\angle CBD$.
- Explain the ambiguous case in the diagram on the right.

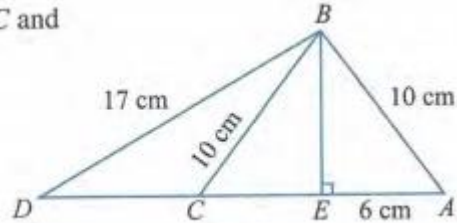

Penyelesaian / Solution :

- $BE = 8 \text{ cm}$, $CE = 6 \text{ cm}$, $DE = 15 \text{ cm}$
- $\angle EAB = 53.13^\circ$, $\angle BCE = 53.13^\circ$, $\angle BCD = 126.87^\circ$, $\angle ABD = 81.20^\circ$, $\angle CBD = 25.06^\circ$,
- Segitiga BDC dan segitiga BDA mempunyai sudut dan dua panjang sisi yang sama saiz.

4. The diagram on the right shows a square picture frame which is hung by Amira using two pieces of ropes. Amira finds that the picture frame inclines towards the right. The angle formed between the longer rope and the frame is 48° . The lengths of the rope are 20 cm and 15 cm respectively. Calculate the perimeter of the frame.



4. The diagram on the right shows a square picture frame which is hung by Amira using two pieces of ropes. Amira finds that the picture frame inclines towards the right. The angle formed between the longer rope and the frame is 48° . The lengths of the rope are 20 cm and 15 cm respectively. Calculate the perimeter of the frame.



Penyelesaian / Solution :

[61.62 cm]

5. Rajah di sebelah menunjukkan kedudukan rumah Puan Azizah dan rumah dua orang anaknya, Amir dan Anita. Seorang lagi anaknya, Aida ingin membina rumah dengan keadaan ketiga-tiga rumah anak Puan Azizah adalah sebaris dan jarak dari rumah Aida dan rumah Anita ke rumah Puan Azizah adalah sama. Cari jarak di antara rumah Anita dengan rumah Aida.

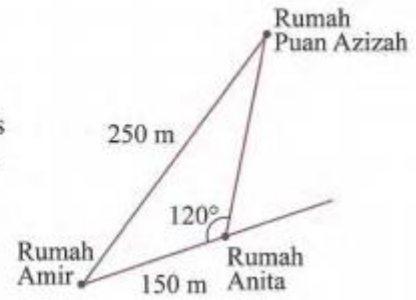

5. The diagram on the right shows the position of Puan Azizah's house and the houses of her two children, Amir and Anita. Another child, Aida wants to build her house such that all the three houses of the siblings are collinear and the distance from her house and Anita's house to Puan Azizah's house is the same. Find the distance between Anita's house and Aida's house.

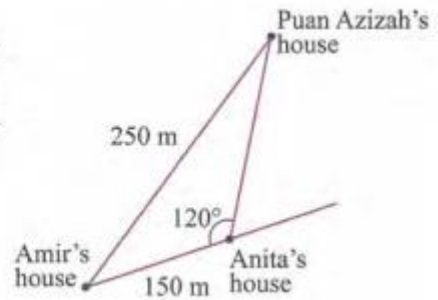

Penyelesaian / Solution :

Menentukan kewujudan dan menyelesaikan masalah kes berambiguiti suatu segi tiga.
Determining the existence and solving triangles involving ambiguous case.

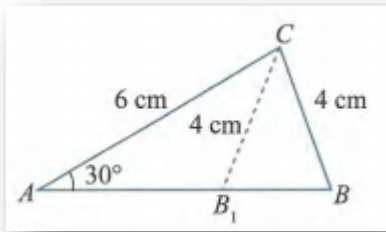

Ambiguiti bermaksud kesamaran atau ketidakpastian yang memungkinkan dua tafsiran dibuat terhadap sesuatu.



Ambiguity means inexactness or the quality of being open to more than one interpretation.

Berdasarkan rajah di atas, perhatikan bahawa dua segi tiga yang berbeza bentuk dapat dibina menggunakan saiz sudut bukan kandung dan panjang dua sisi yang diberi. Dua segi tiga yang dapat dibina dengan satu set maklumat yang sama seperti ini dikenali sebagai **kes berambiguiti**.

Based on the diagram above, it is observed that two different triangles can be constructed by using the given non-included angle and lengths of two sides. The two triangles can be constructed by using the same set of information given. This is known as **ambiguous case**.

<p>Dua segi tiga wujud</p>	<p>$h < a < c$</p>	<p>$h < a < c$</p>
<p>Two triangles exist</p>	<p>$h < a < c$</p>	<p>$h < a < c$</p>

Kes berambiguiti wujud jika:

- Diberi panjang dua sisi, a dan c , serta satu sudut bukan kandung, $\angle A$ yang tirus.
- Sisi yang bertentangan dengan sudut bukan kandung, a lebih pendek daripada sisi yang satu lagi, c tetapi lebih panjang daripada tinggi segi tiga, h .

Ambiguous case exists if:

- Given the lengths of two sides, a and c , and a non-included angle, $\angle A$ which is acute.
- The side which is opposite the non-included angle, a is shorter than the other side, c , but it is longer than the height, h , of the triangle.

Tugasan 1 : Bagi setiap segitiga berikut, tentukan sama ada wujud kes berambiguiti atau tidak.

Task 1: For each of the following triangles, determine whether ambiguous case exists.

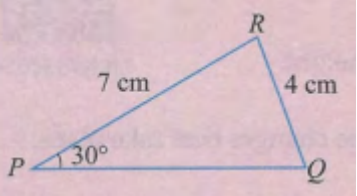
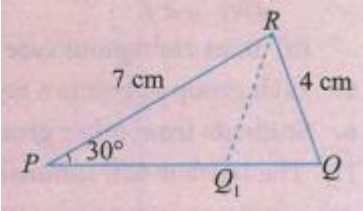
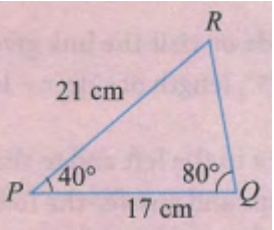
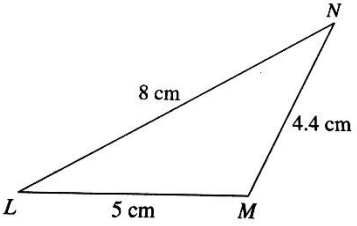
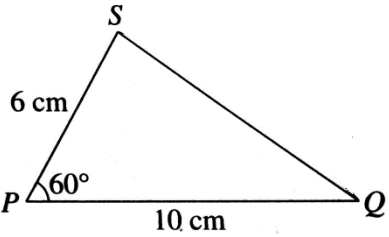
<p>(1)</p> 	<p>Penyelesaian / Solution :</p> <p>Ya , wujud kes berambiguiti dalam segitiga PQR dengan sudut bukan kandung $\angle RPQ = 30^\circ$ dan sisi RQ lebih pendek daripada sisi PR tetapi lebih panjang daripada tinggi segitiga .</p> <p><i>Yes, ambiguous case exists in triangle PQR because the non-included angle $\angle RPQ = 30^\circ$ and the side RQ is shorter than the side PR but it is longer than the height of the triangle.</i></p> 
<p>(2)</p> 	<p>Penyelesaian / Solution :</p> <p>Tidak wujud kes berambiguiti kerana dua sudut telah diberi.</p> <p><i>Ambiguous case does not exist because the angles of the two sides are given.</i></p>
<p>(3)</p> 	<p>Penyelesaian / Solution :</p> <p>[yes]</p>
<p>(4)</p> 	<p>Penyelesaian / Solution :</p> <p>[yes]</p>
<p>(5) ΔPQR; $\angle R = 28^\circ$, $QR = 8.2 \text{ cm}$ dan $PQ = 11.4 \text{ cm}$</p>	<p>Penyelesaian / Solution :</p> <p>[No]</p>

9.2 Petua Kosinus / Cosine rule

Petua kosinus boleh digunakan untuk mencari panjang atau sudut yang tidak diketahui dalam segitiga apabila

- i) panjang dua sisi dan **satu sudut kandung** diberi
panjang ketiga- tiga sisi diberi.

Cosine rule can be used to find the length or unknown angle in a triangle when,

- i) *the lengths of two sides and **an included angle** are given,*
- ii) *the lengths of three sides are given.*

$$\cos A = \frac{b^2 + c^2 - a^2}{2bc}$$

$$\cos B = \frac{a^2 + c^2 - b^2}{2ac}$$

$$\cos C = \frac{a^2 + b^2 - c^2}{2ab}$$

Petua Kosinus

Bagi sebarang segi tiga ABC ,

$$a^2 = b^2 + c^2 - 2bc \cos A$$

$$b^2 = a^2 + c^2 - 2ac \cos B$$

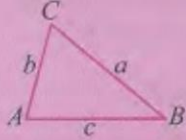
$$c^2 = a^2 + b^2 - 2ab \cos C$$

Cosine rule

For any triangle ABC ,

$$a^2 = b^2 + c^2 - 2bc \cos A$$

$$b^2 = a^2 + c^2 - 2ac \cos B$$

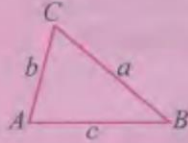
$$c^2 = a^2 + b^2 - 2ab \cos C$$

Tugasan 1 : Cari panjang sisi yang tidak diketahui bagi setiap segitiga berikut apabila 2 sisi dan satu sudut kandung diberi.

Task 1 : Find the unknown side of a triangle when two sides and an included angle are given.

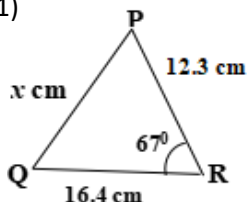
<p>(1)</p>  <p style="text-align: center;">Diagram 1</p> <p>Rajah 1 menunjukkan segitiga PQR dengan PR = 12.3 cm , QR = 16.4 cm dan $\angle PRQ = 67^\circ$. Cari nilai x.</p> <p>Diagram 1 shows the triangle PQR such that PR = 12.3 cm , QR = 16.4 cm and $\angle PRQ = 67^\circ$. Find the value of x.</p>	<p>Penyelesaian / Solution :</p> $x^2 = 16.4^2 + 12.3^2 - 2(16.4)(12.3) \cos 67^\circ$ $= 262.1$ $x = \sqrt{262.61}$ $x = 16.21$
-------------------------------------------------------------------------------------------------------------------------------------------------------------------------------------------------------------------------------------------------------------------------------------------------------------------------------------------------------------------------------------------------------------------------------------------------	----------------------------------------------------------------------------------------------------------------------------------

(2)

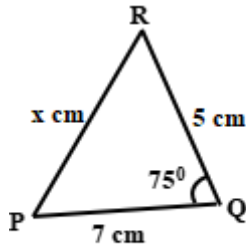

Diagram 2

Rajah 2 menunjukkan segitiga PQR dengan $PQ = 7$ cm, $QR = 5$ cm dan $\angle PQR = 75^\circ$. Cari nilai x .

Diagram 2 shows the triangle PQR such that $PQ = 7$ cm, $QR = 5$ cm and $\angle PQR = 75^\circ$. Find the value of x .

[7.475]

Penyelesaian / Solution :

(3)

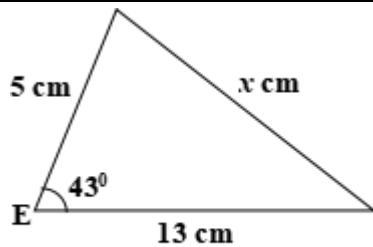

Diagram 3

Rajah 3 menunjukkan segitiga dengan sisi 5 cm, 13 cm dan satu sudut kandung 43° . Cari nilai x .

Diagram 3 shows a triangle with sides 5 cm, 13 cm and an included angle 43° . Find the value of x .

[9.946]

Penyelesaian / Solution :

(4)

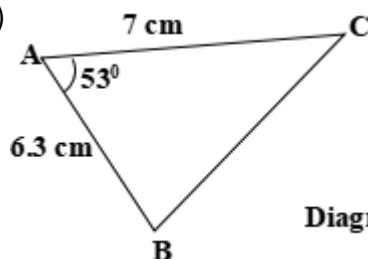

Diagram 4

Diagram 4 shows the triangle PQR. Find the length of BC.

[5.967 cm]

Penyelesaian / Solution :

(5)

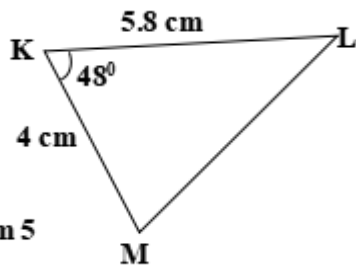

Diagram 5

Penyelesaian / Solution :

Rajah 5 menunjukkan segitiga KLM. Cari panjang LM.

Diagram 5 shows the triangle KLM. Find the length of LM.

[4.312 cm]

(6)

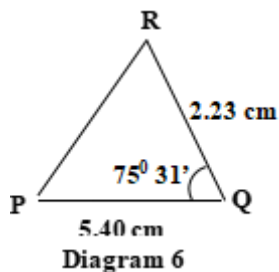

Diagram 6

Penyelesaian / Solution :

Rajah 6 menunjukkan segitiga PQR. Cari panjang PR.

Diagram 6 shows the triangle PQR. Find the length of PR.

[5.302 cm]

(7)

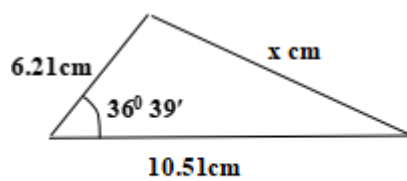

Diagram 7

Penyelesaian / Solution :

Rajah 7 menunjukkan segitiga dengan sisi 6.21 cm , 10.51 cm dan satu sudut kandung $36^\circ 39'$. Cari nilai x.

Diagram 7 shows a triangle with sides 6.21 cm , 10.51 cm and an included angle $36^\circ 39'$. Find the value of x .

[6.656]

Tugasan 2 : Cari sudut yang tidak diketahui bagi setiap segitiga berikut apabila 3 sisi diberi.

Task 2 : Find the unknown angle of a triangle when three sides are given.

(1)

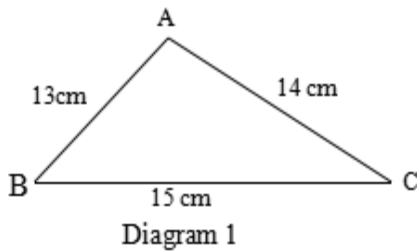

Penyelesaian / Solution :

$$\cos \angle BAC = \frac{13^2 + 14^2 - 15^2}{2(13)(14)}$$

$$= 0.3846$$

Dalam Rajah 1, ABC ialah sebuah segitiga dengan AB = 13 cm, AC = 14 cm dan BC = 15 cm. Cari $\angle BAC$.

$$\angle BAC = 67.38^\circ$$

In Diagram 1, ABC is a triangle where AB = 13 cm, AC = 14 cm and BC = 15 cm. Find $\angle BAC$

(2)

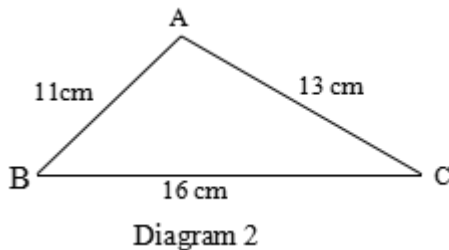

Penyelesaian / Solution :

Rajah 2 menunjukkan segitiga ABC dengan AB = 11 cm, AC = 13 cm dan BC = 16 cm. Cari $\angle BAC$.

Diagram 2 shows a triangle ABC where AB = 11 cm, AC = 13 cm and BC = 16 cm. Find $\angle BAC$

[83.17°]

(3)

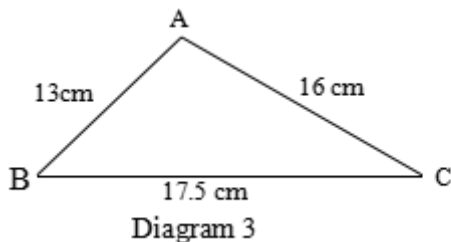

Penyelesaian / Solution :

Rajah 3 menunjukkan sebuah segitiga ABC dengan AB = 13 cm, AC = 16 cm dan BC = 17.5 cm. Hitung $\angle BAC$

Diagram 3 shows a triangle ABC where AB = 13 cm, AC = 16 cm and BC = 17.5 cm. Calculate $\angle BAC$

[73.41°]

(4)

Penyelesaian / Solution :

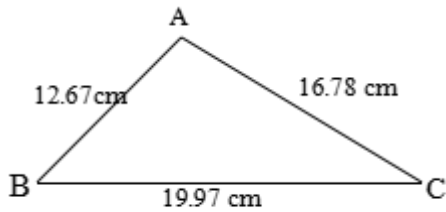

Diagram 4

Rajah 4 menunjukkan sebuah segitiga ABC dengan $AB = 12.67$ cm, $AC = 16.78$ cm dan $BC = 19.97$ cm. Hitung $\angle BCA$

Diagram 4 shows a triangle ABC where $AB = 12.67$ cm, $AC = 16.78$ cm and $BC = 19.97$ cm. Calculate $\angle BCA$

[39.17°]

(5)

Penyelesaian / Solution :

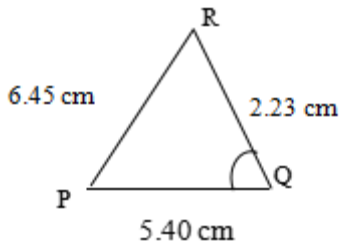

Diagram 5

Dalam Rajah 5, PQR ialah sebuah segitiga dengan $PR = 6.45$ cm, $RQ = 2.23$ cm dan $PQ = 5.40$ cm. Find $\angle RQP$.

In Diagram 5, PQR is a triangle such that $PR = 6.45$ cm, $RQ = 2.23$ cm and $PQ = 5.40$ cm. Find $\angle RQP$.

[108.07°]

(6)

Penyelesaian / Solution :

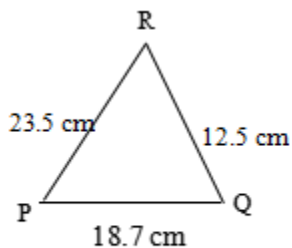

Diagram 6

Dalam Rajah 6, PQR ialah sebuah segitiga dengan $PR = 23.5$ cm, $RQ = 12.5$ cm dan $PQ = 18.7$ cm. Hitung sudut terkecil dalam segitiga PQR.

In Diagram 6, PQR is a triangle such that $PR = 23.5$ cm, $RQ = 12.5$ cm and $PQ = 18.7$ cm. Calculate the smallest angle in the triangle.

[31.96°]

(7)

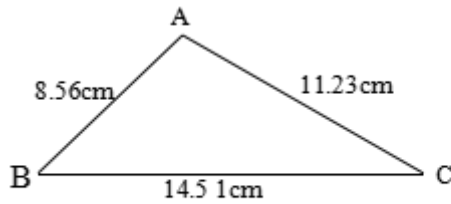

Diagram 7

Bagi segitiga ABC dalam Rajah 7, $AB = 8.56$ cm, $AC = 11.23$ cm dan $BC = 14.51$ cm. Hitung sudut yang terbesar dalam segitiga ABC.

For triangle ABC in Diagram 7, $AB = 8.56$ cm, $AC = 11.23$ cm and $BC = 14.51$ cm. Calculate the largest angle in the triangle

Penyelesaian / Solution :

[93.33°]

(8)

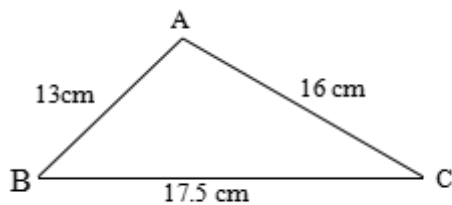

Diagram 8

Bagi segitiga ABC dalam Rajah 8, $AB = 13$ cm, $AC = 16$ cm dan $BC = 17.5$ cm. Hitung sudut kedua terbesar dalam segitiga ABC.

For triangle ABC in Diagram 8, $AB = 13$ cm, $AC = 16$ cm and $BC = 17.5$ cm. Calculate the second largest angle in the triangle.

Penyelesaian / Solution :

[61.19°]

Menyelesaikan masalah melibatkan petua kosinus.

Solving problems involving cosine rule.

1. Farid menjalani latihan memanah di sebuah padang. Rajah di sebelah menunjukkan dua buah papan sasaran yang perlu dipanah oleh Farid. Jarak di antara Farid dengan papan I dan papan II masing-masing ialah 25 m dan 45 m. Kedudukan Farid mula memanah ialah 38° antara papan I dan papan II. Hitung jarak di antara papan I dengan papan II.

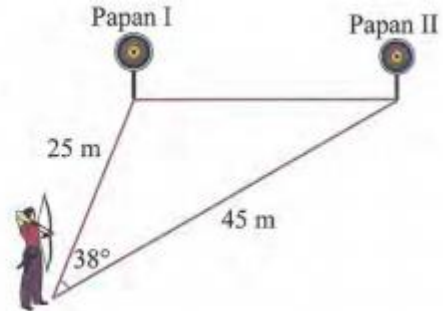

1. Farid carried out archery training on a field. The diagram on the right shows two target boards which have to be struck by arrows. The distance between Farid and board I and board II are 25 m and 45 m respectively. The standing position of the shooting is 38° between board I and board II. Calculate the distance between board I and board II.

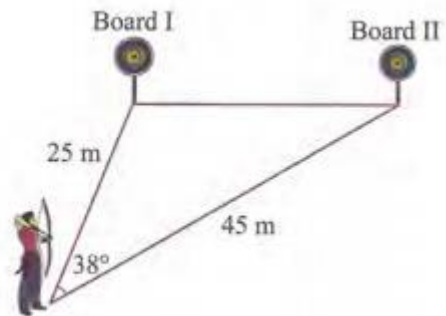

Penyelesaian / *Solution* :

	$x^2 = 25^2 + 45^2 - 2(25)(45) \cos 38^\circ$ $x = \sqrt{876.9758}$ $x = 29.614 \text{ m}$
--	--------------------------------------------------------------------------------------------

[29.614 m]

(2)

Rajah di sebelah menunjukkan kedudukan rumah empat orang rakan, iaitu Amin, Ilya, Johan dan Raden. Pada hari raya, Amin ingin menziarahi ketiga-tiga buah rumah rakannya itu. Amin bercadang untuk membawa Ilya dan kemudian menghantarnya semula sebelum pulang ke rumah. Berapakah jumlah jarak bagi keseluruhan perjalanan yang akan dilalui oleh Amin?

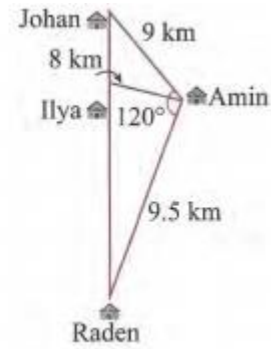

The diagram on the right shows the positions of the house of four friends, Amin, Imran, Johan and Raden. During Hari Raya, Amin wants to visit all the three houses of his friends. Amin intends to pick up Imran and then send him back home before he returns to his house. What is the total distance travelled by Amin for the whole journey?

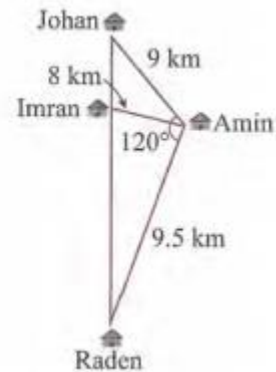

Penyelesaian / Solution :

[48.046 km]

3. Kapal Bunga Raya meninggalkan sebuah pelabuhan dan belayar ke arah timur sejauh 28 km. Kapal Bunga Orkid pula meninggalkan pelabuhan yang sama dan belayar sejauh 49 km. Jika jarak akhir di antara kedua-dua buah kapal itu ialah 36 km, cari sudut antara laluan kapal Bunga Raya dengan laluan kapal Bunga Orkid.
3. Bunga Raya ship left a port and sailed east for a distance of 28 km. Bunga Orkid ship left the same port and sailed for 49 km. If the final distance between the two ships is 36 km, find the angle between the routes of Bunga Raya ship and Bunga Orkid ship.

Penyelesaian / Solution :

[46.50°]

4. Rajah di sebelah menunjukkan sebuah kolam berbentuk segi tiga MNP . Diberi $\cos \theta = \frac{4}{5}$, $MP = 8$ m, $PQ = 7$ m dan $QN = 4$ m. Encik Raja memasang batu di sekeliling kolam itu. Hitung panjang batu di sekeliling kolam yang dipasang oleh Encik Raja.

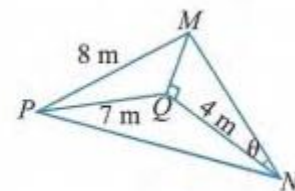

4. The diagram on the right shows a pond in the shape of triangle MNP . Given $\cos \theta = \frac{4}{5}$, $MP = 8$ m, $PQ = 7$ m and $QN = 4$ m. Encik Raja decorates the pond by arranging stones around the pond. Calculate the length of stones arranged by Encik Raja around the pond.

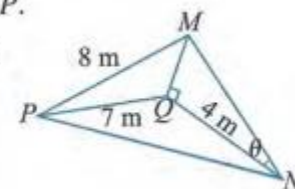

Penyelesaian / Solution :

[23.974 m]

BAB 9 : PENYELESAIAN SEGITIGA
CHAPTER 9 : SOLUTIONS OF TRIANGLE

FORM 4 CHAPTER 9 – SOLUTIONS OF TRIANGLE

9.3 Area of a Triangle

9.3.1 Derive the formula for area of triangles, and hence determine the area of a triangle.

9.3.2 Determine the area of a triangle using the Heron's formula.

9.3.3 Solve problems involving areas of triangles.

9.4 Application of Sine Rule, Cosine Rule and Area of a Triangle

9.4.1 Solve problems involving triangles

Area of Triangles

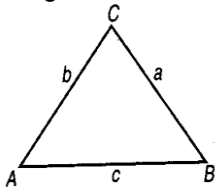

$$\begin{aligned} \text{Area of } \triangle ABC &= \frac{1}{2} ab \sin C \\ &= \frac{1}{2} ac \sin B \\ &= \frac{1}{2} bc \sin A \end{aligned}$$

EXERCISE 9.3.1

1 Find the area of the following triangles.

a) Answer 50.07 cm^2

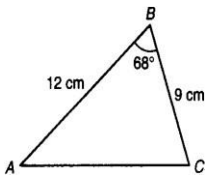

b) Answer [57.22 cm^2]

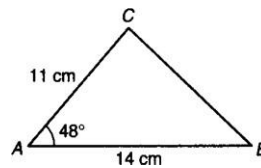

c) Answer [40.13 cm^2]

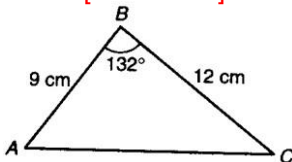

d) Answer [56.82 cm^2]

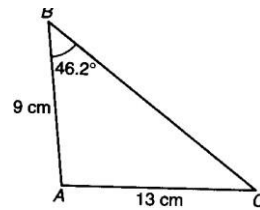

e) Answer [50 cm^2]

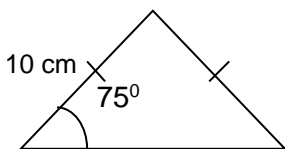

f) Answer [6 cm^2]

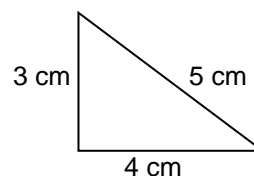

Heron's formula :

Area of Triangle

$$= \sqrt{s(s-a)(s-b)(s-c)}$$

When a, b and c is the length of triangle

$$s = \frac{a+b+c}{2}$$

EXERCISE 9.3.2

1 Find the area of the following triangles.

a) Answer [14.697cm²]

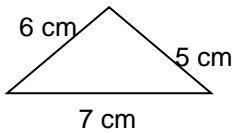

b) Answer [21.615cm²]

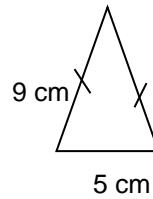

c) Answer [6 cm²]

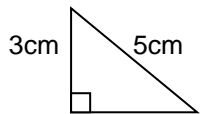

d) Answer [61.482cm²]

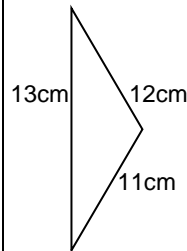

e) Answer [33.63cm²]

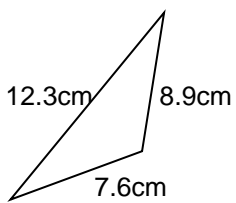

f) Answer [13.659 cm²]

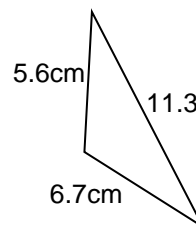

EXERCISE 9.3.3

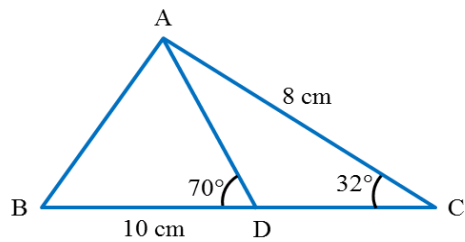

1. Diagram above shows a triangle ABC , where $AC = 8\text{ cm}$ and $\angle C = 32^\circ$. Point D lies on straight line BC where $BD = 10\text{ cm}$ and $\angle ADB = 70^\circ$. Calculate

- (a) the length, in cm , of CD ,
- (b) the area, in cm^2 of ΔADC ,
- (c) the area, in cm^2 of ΔABC ,
- (d) the length, in cm , of AB .

Answer (a) 5.243 (b) 11.12 (c) 32.315 (d) 9.462

2.

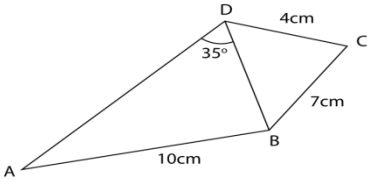

The diagram shows a quadrilateral $ABCD$. The area of triangle BCD is 12 cm^2 and BCD is acute.

Calculate

(a) $\angle BCD$,

(b) the length, in cm, of BD ,

(c) $\angle ABD$,

(d) the area, in cm^2 , quadrilateral $ABCD$.

Answer (a) 59° (b) 6.013 (c) 124.82 (d) 36.68

3. In the diagram below, ABC is a triangle. $AGJB$, AHC and BKC are straight lines. The straight line JK is perpendicular to BC .

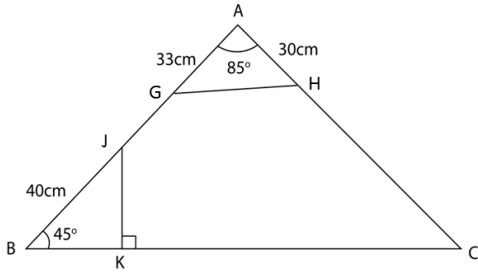

It is given that $BG = 40\text{cm}$, $GA = 33\text{ cm}$, $AH = 30\text{ cm}$, $GAH = 85^\circ$ and $JBK = 45^\circ$.

- (a) Calculate the length, in cm, of GH and HC .
 (b) The area of triangle GAH is twice the area of triangle JBK . Calculate the length, in cm, of BK .
 (c) Sketch triangle which has a different shape from triangle ABC such that $A'B' = AB$, $A'C' = AC$ and $A'B'C' = ABC$.

Answer (a) $GH = 42.62$, $HC = 37.38$ (b) $BK = 22.21$

(c)

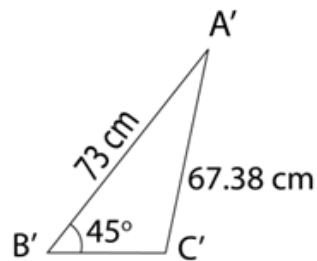

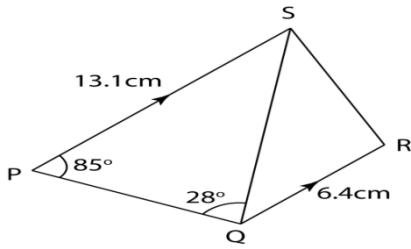

4. The diagram shows a trapezium $PQRS$. PS is parallel to QR and QRS is obtuse. Find

- (a) the length, in cm, of QS ,
- (b) the length, in cm, of RS ,
- (c) $\angle QRS$,
- (d) the area, in cm^2 , of triangle QRS .

Answer (a) 27.8 (b) 25.98 (c) 99.86 (d) 81.91

5. Diagram below shows a quadrilateral $PQRS$.

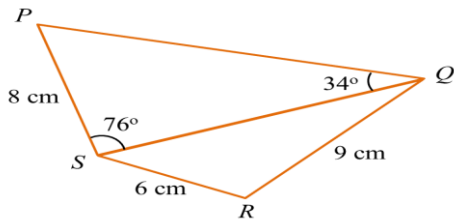

(a) Find

(i) the length, in cm, of QS .

(ii) $\angle QRS$.

(iii) the area, in cm^2 , of the quadrilateral $PQRS$.

(b)(i) Sketch a triangle $S'Q'R'$ which has a different shape from triangle SQR such that $S'R' = SR$, $S'Q' = SQ$ and $\angle S'Q'R' = \angle SQR$.

(ii) Hence, state $\angle S'R'Q'$.

Answer a(i) 13.44 (ii) $126^\circ 6'$ (iii) 73.98

b)(i)

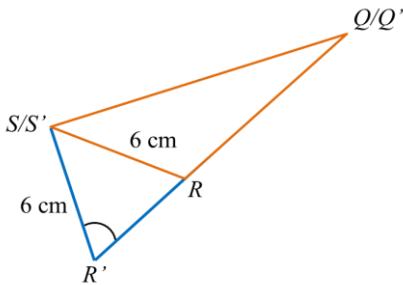

(b)(ii) $53^\circ 54'$

6. The diagram below shows a triangle ABC .

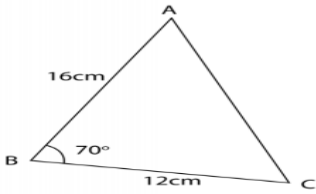

- (a) Calculate the length, in cm, of AC .
- (b) A quadrilateral $ABCD$ is now formed so that AC is a diagonal, $\angle ACD = 45^\circ$ and $AD = 14$ cm. Calculate the two possible values of $\angle ADC$.
- (c) By using the acute $\angle ADC$ from (b), calculate
- (i) the length, in cm, of CD ,
 - (ii) the area, in cm^2 , of the quadrilateral $ABCD$

Answer (a) 16.39 (b) 55.87° or 124.13° (c) (i) 19.44 (ii) 202.88

7 Diagram below shows trapezium $ABCD$.

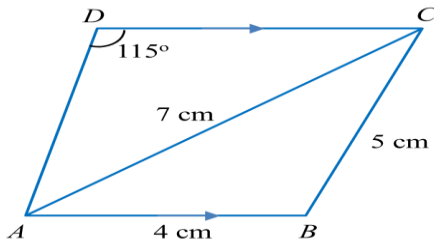

(a) Calculate

(i) $\angle BAC$.

(ii) the length, in cm, of AD .

(b) The straight line AB is extended to B' such that $BC = B'C$.

(i) Sketch the trapezium $AB'CD$.

(ii) Calculate the area, in cm^2 , of $\triangle BB'C$.

Answer (a) (i) $44^\circ 25'$ (ii) 5.406

(b) (ii) 4.898

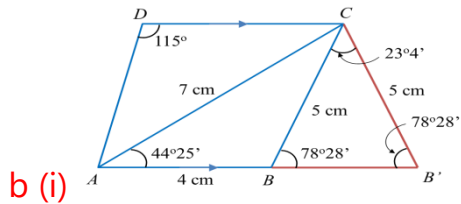

b (i)

8 Diagram below shows a quadrilateral $ABCD$ where the sides AB and CD are parallel. $\angle BAC$ is an obtuse angle.

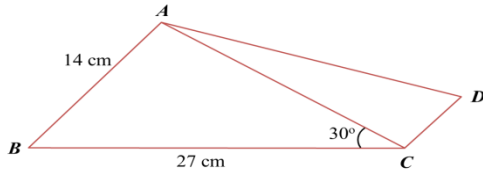

Given that $AB = 14$ cm, $BC = 27$ cm, $\angle ACB = 30^\circ$ and $AB : DC = 7 : 3$.

Calculate

- (a) $\angle BAC$.
- (b) the length, in cm, of diagonal BD .
- (c) the area, in cm^2 , of quadrilateral $ABCD$.

Answer (a) 105.36° (b) 31.55 (c) 189.7

9 Diagram below shows a cyclic quadrilateral $PQRS$.

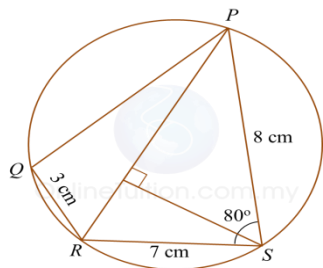

(a) Calculate

(i) the length, in cm, of PR ,

(ii) $\angle PRQ$.

(b) Find

(i) the area, in cm^2 , of ΔPRS ,

(ii) the short distance, in cm, from point S to PR .

Answer (a) (i) 9.6722 (ii) $62^{\circ}13'$ (b) (i) 27.5746 (ii) 27

EXERCISE 9.4.1

1 Solve problems involving three-dimensional objects

a) Calculate $\angle BGE$ [Answer 70.17°]

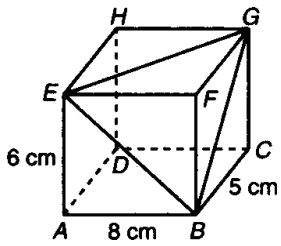

b) Calculate i) Length of PS ii) $\angle PSQ$
[Answer 16.76 cm , 83.41°]

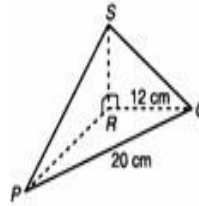

c) [Answer i) 25.8° ii) 15.82 cm^2]

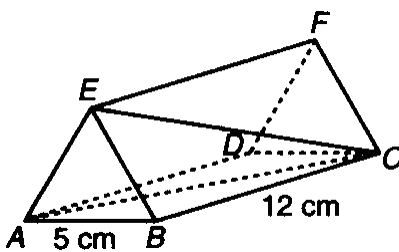

ABE and *DCF* are equilateral triangle
BCFE and *ADFE* are rectangle.
Calculate
i) $\angle ACE$
ii) Area of $\triangle AEB$

d) [Answer i) 70.2° ii) 34.66 cm^2]

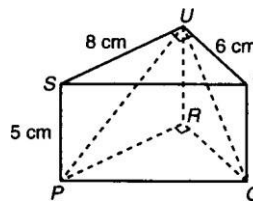

Base on the diagram given on the left
Calculate
i) $\angle PUQ$
ii) area of $\triangle PUQ$

SPM – QUESTIONS

PAPER 2
(SOLUTION OF TRIANGLE)

YEAR 2003

1. Diagram 5 shows a tent $VABC$ in the shape of a pyramid with triangle ABC as the horizontal base. V is the vertex of the tent and the angle between the inclined plane VBC and the base is 50° .

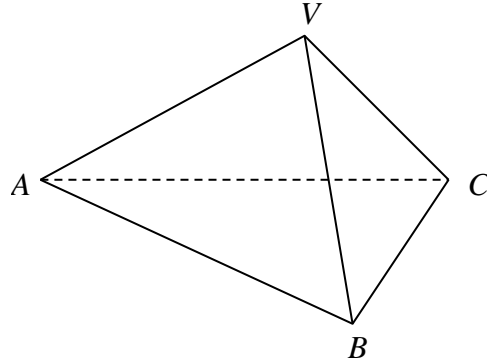

Diagram 5

Given that $VB = VC = 2.2$ m and $AB = AC = 2.6$ m, calculate

- (a) the length of BC if the area of the base is 3 m^2 , [3 marks]
(b) the length of AV if the angle between AV and the base is 25° , [3 marks]
(c) the area of triangle VAB . [4 marks]

YEAR 2004

2. Diagram 6 shows a quadrilateral $ABCD$ such that $\angle ABC$ is acute.

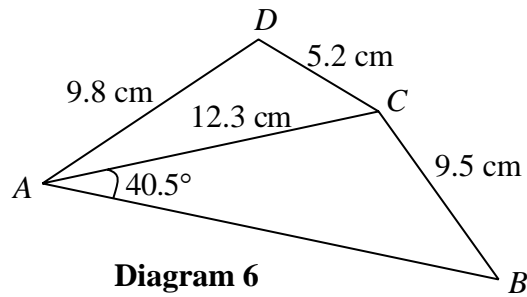

Diagram 6

- (a) Calculate

- (i) $\angle ABC$,
- (ii) $\angle ADC$,
- (iii) the area, in cm^2 , of quadrilateral $ABCD$.

[8 marks]

- (b) A triangle $A'B'C'$ has the same measurements as those given for triangle ABC , that is, $A'C' = 12.3$ cm, $C'B' = 9.5$ cm and $\angle B'A'C' = 40.5^\circ$, but which is different in shape to triangle ABC .

- (i) Sketch the triangle $A'B'C'$,
- (ii) State the size of $\angle A'B'C'$.

[2 marks]

YEAR 2005

3. Diagram 7 shows triangle ABC .

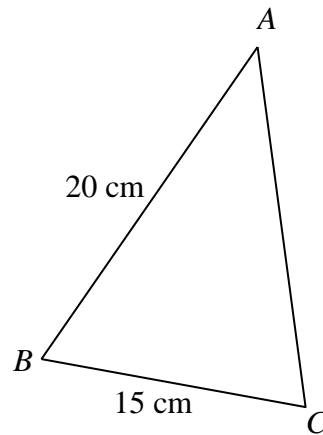

Diagram 7

- (a) Calculate the length, in cm, of AC . [2 marks]
- (b) A quadrilateral $ABCD$ is now formed so that AC is a diagonal, $\angle ACD = 40^\circ$ and $AD = 16$ cm. Calculate the two possible values of $\angle ADC$. [2 marks]
- (c) By using the acute $\angle ADC$ from (b), calculate
- (i) the length, in cm, of CD ,
 - (ii) the area, in cm^2 , of the quadrilateral $ABCD$. [6 marks]

YEAR 2006

4. Diagram 5 shows a quadrilateral $ABCD$.

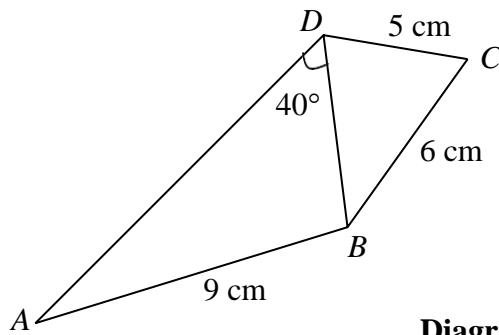

Diagram 5

The area of triangle BCD is 13 cm^2 and $\angle BCD$ is acute.

Calculate

(a) $\angle BCD$,

[2 marks]

(b) the length, in cm, of BD ,

[2 marks]

(c) $\angle ABD$,

[3 marks]

(d) the area, in cm^2 , quadrilateral $ABCD$.

[3 marks]

YEAR 2007

5. Diagram 7 shows quadrilateral $ABCD$.

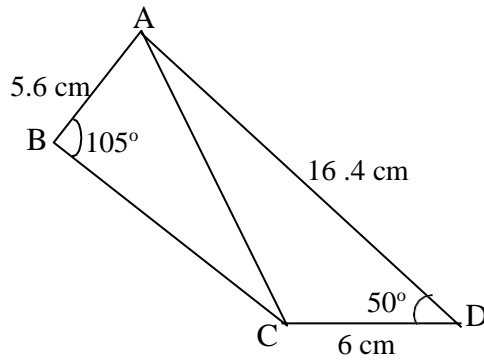

Diagram 7

- (a) Calculate
- the length, in cm, of AC ,
 - $\angle ACB$.
- [4 marks]
- (b) Point A' lies on AC such that $A'B = AB$.
- Sketch $\triangle A'BC$.
 - Calculate the area, in cm^2 , of $\triangle A'BC$.
- [6 marks]

YEAR 2008

6. In Diagram 14, ABC is a triangle. $ADFB$, AEC and BGC are straight lines. The straight line FG is perpendicular to BC .

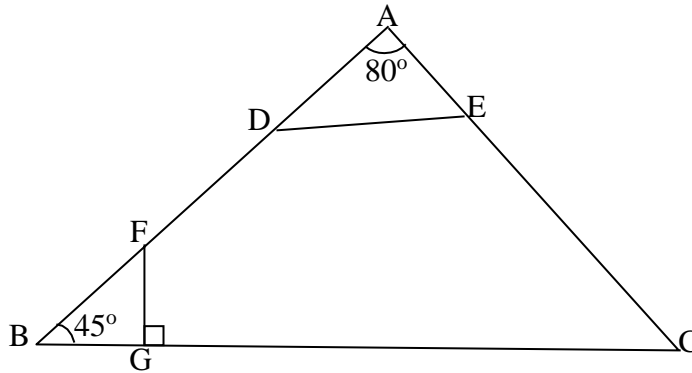

Diagram 14

It is given that $BD = 19$ cm, $DA = 16$ cm, $AE = 14$ cm, $\angle DAE = 80^\circ$ and $\angle FBG = 45^\circ$.

- a) Calculate the length, in cm, of
- (i) DE ,
 - (ii) EC . [5 marks]
- b) The area of triangle DAE is twice the area of triangle FBG . Calculate the length, in cm, of BG . [4 marks]
- c) Sketch triangle $A'B'C'$ which has a different shape from triangle ABC such that $A'B' = AB$, $A'C' = AC$ and $\angle A'B'C' = \angle ABC$. [1 marks]

Answer SPM PAPER 2

1. (a) 2.70 cm
(b) 3.149 cm
(c) 2.829 cm^2

2. (a) (i) 57.23°
(ii) 106.07°
(iii) 80.96 cm^2

(b) (i)

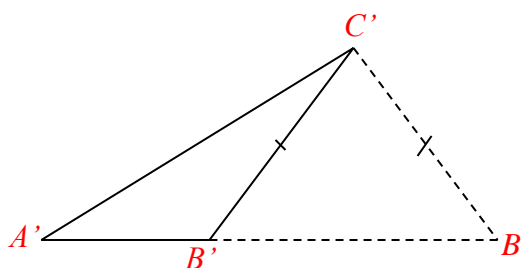

(ii) 122.77°

3. (a) 19.27 cm
(b) $\angle AD_1C = 129.27^\circ$, $\angle AD_2C = 50.73^\circ$
(c) (i) 24.89 cm
(ii) 290.1 cm^2

4. (a) 60.07° or $60^\circ 4'$
(b) 5.573 cm
(c) 116.55° or $116^\circ 33'$
(d) 35.43 cm^2

5. (a) (i) $AC = 13.36$ (ii) $23^\circ 53'$

(b) (i) B (ii) 13.80 cm

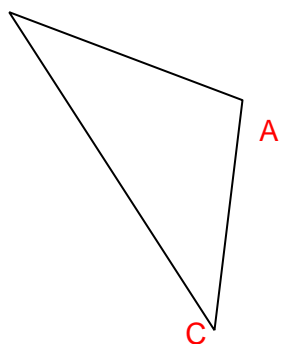

6. (i) 19.43 (ii) 16.21 (b) $BG = 10.5 \text{ cm}$

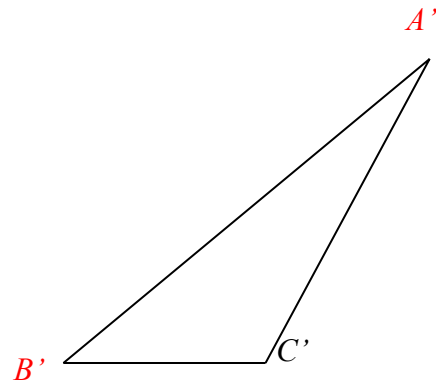

BAB 10: NOMBOR INDEKS
CHAPTER 10: INDEX NUMBERS

10.1 Nombor Indeks/ *Index Number*

10.1.1 Mentakrif nombor indeks / *Defining index number*

10.1.2 Mentafsir nombor indeks / *Describing index number*

NOTA/NOTES

✚ **Nombor indeks** ialah satu ukuran yang menunjukkan perubahan suatu kuantiti pada suatu masa tertentu berbanding dengan masa asas.
An index number is a measure that shows the change in a quantity at the specific time compared to the base time.

✚ Nilai kuantiti pada masa asas biasanya diberikan nombor **100** dan nombor indeks pada bila – bila masa lain adalah berkadarannya.
The value of the quantity at the base time is conventionally given the number 100 and the index number if any other time is in proportion with it.

✚ Rumus bagi nombor indeks ialah:
The formula for index number is:

$$I = \frac{Q_1}{Q_0} \times 100$$

Dengan keadaan / where

Q_0 = kuantiti/ harga pada masa asas
Quantity / price at the base time

Q_1 = kuantiti / harga pada masa tertentu
Quantity / price at a specific time

1. Tentukan dan tafsirkan nombor indeks dalam setiap situasi yang berikut.
Determine and interpret the index number in each of the following situations.

TP 2

CONTOH / EXAMPLE:

Harga seutas jam tangan berjenama X pada tahun 2017 dan 2018 masing – masing ialah RM 500 dan RM 550. Hitung nombor indeks bagi harga jam tangan itu pada tahun 2018 berasaskan tahun 2017. Tafsirkan nombor indeks yang diperoleh.

The price of an X – branded watch in the year 2017 and 2018 was RM 500 and RM 550 respectively. Calculate the index number of the price of the watch in the year 2018 based on the year 2017. Interpret the index number obtained.

Penyelesaian / *Solution:*

Andaikan / *Let:*

Q_0 = Harga pada tahun 2017 / *Price in the year 2017*

Q_1 = Harga pada tahun 2018 / *Price in the year 2018*

$$\begin{aligned} \text{Nombor Indeks, } I &= \frac{Q_1}{Q_0} \times 100 \\ &= \frac{550}{500} \times 100 \\ &= 110 \end{aligned}$$

Maka, terdapat peningkatan harga sebanyak 10% dari tahun 2017 ke tahun 2018.

Thus, there is an increase of 10% in the price from the year 2017 to the year 2018.

- 1) Sebuah kantin sekolah mendapat keuntungan RM 40 000 pada tahun 2016 dan RM 58 000 pada tahun 2018. Hitung nombor indeks yang menunjukkan perubahan keuntungan kantin sekolah itu pada tahun 2018 berdasarkan tahun 2016. Seterusnya, tafsirkan nombor indeks yang diperoleh.

A school canteen made a profit of RM 40 000 in the year 2016 and RM 58 000 in the year 2018. Calculate the index number to show the change in profit for the school canteen in the year 2018 based on the year 2016. Hence, interpret the index number obtained.

145 / Peningkatan 45%

- 2) Bilangan komputer yang dijual di sebuah kedai pada tahun 2011 dan 2018 masing – masing ialah 320 buah dan 560 buah. Hitung indeks jualan pada tahun 2018 berdasarkan tahun 2011. Seterusnya, tafsirkan indeks jualan yang diperoleh.

The number of computers sold in a shop in the years 2011 and 2018 were 320 and 560 respectively. Calculate the sales index in the year 2018 based on the year 2011. Hence, interpret the sales index obtained.

175 / peningkatan 75%

2. Hitungkan setiap yang berikut.
Calculate each of the following.

TP 3

CONTOH / EXAMPLE:

Pendaftaran badan sukan yang diterima oleh Pejabat Pesuruhjaya Sukan (PJS) pada tahun 2017 ialah sebanyak 893. Diberi nombor indeks bagi pendaftaran badan sukan pada tahun 2017 berasaskan tahun 2010 ialah 156.39, hitung bilangan pendaftaran badan sukan pada tahun 2010.

In the year 2017, the number of sports governing bodies registered with the Sport Commissioner Office is 893. Given that the index number of the registration of sports governing bodies of the year 2017 based on the year 2010 is 156.39, calculate the number of sports governing bodies registered in the year 2010.

Penyelesaian / solution:

Andaikan / Let:

Q_0 = Bilangan pendaftaran pada tahun 2010 / *the number of registration in the year 2010*

Q_1 = Bilangan pendaftaran pada tahun 2017 / *the number of registration in the year 2017*

$$I = \frac{Q_1}{Q_0} \times 100$$
$$156.39 = \frac{893}{Q_0} \times 100$$
$$Q_0 = 571$$

- 1) Satu kajian mengenai bilangan kemalangan jalan raya telah dijalankan. Bilangan kemalangan jalan raya pada tahun 2010 ialah 13 260. Diberi indeks kemalangan pada tahun 2010 berasaskan tahun 2008 ialah 130. Hitung bilangan kemalangan jalan raya pada tahun 2008.

A survey has been made on the number of road accidents. The number of road accidents in the year 2010 was 13 260. Given the accident index in the year 2010 based on the year 2008 is 130, calculate the number of road accidents in the year 2008.

- 2) Harga sebuah motorsikal pada tahun 2016 ialah RM 6 750. Diberi indeks harga bagi motorsikal itu pada tahun 2016 berdasarkan tahun 2014 ialah 125, hitung motorsikal itu pada tahun 2014.

The price of a motorcycle in the year 2016 was RM 6 750. Given the price of the motorcycle in the year 2016 based on the year 2014 is 125, calculate the price of the motorcycle in the year 2014.

5 400

- 3) Indeks kemalangan jalan raya bagi sebuah bandar pada tahun 2012 berdasarkan tahun 2016 ialah 75. Jika bilangan kemalangan jalan raya yang berlaku pada tahun 2016 ialah 460, cari bilangan kemalangan jalan raya pada tahun 2012.

The road accident index of a certain town in the year 2012 based on the year 2016 was 75. If the number of road accidents occurred in the year 2016 was 460, find the number of road accidents occurred in the year 2012.

345

- 4) Indeks harga bagi sebuah rumah teres dua tingkat pada tahun 2000 berdasarkan tahun 1984 ialah 150. Jika harga rumah teres itu ialah RM 139 500 pada tahun 2000, cari harganya pada tahun 1984.

The price index of a double storey terrace in the year 2000 based on the year 1984 was 150. If the price of the terrace was RM 139 500 in the year 2000, find its price in the year 1984.

93 000

3. Hitungkan nombor indeks bagi setiap situasi berikut.
Calculate the index number for each of the following situations.

CONTOH / EXAMPLE:

Indeks harga bagi sebuah basikal pada tahun 2018 berasaskan tahun 2010 dan 2015 masing – masing ialah 176 dan 110. Cari indeks harga basikal itu pada tahun 2015 berasaskan tahun 2010.

The price index of a bicycle in the year 2018 based on the year 2010 and 2015 was 176 and 110 respectively. Find the price index of the bicycle in the year 2015 based on the year 2010.

Jawapan / Answer:

$$\frac{Q_{2018}}{Q_{2010}} \times 100 = 176 \dots \dots \dots (1)$$

$$\frac{Q_{2018}}{Q_{2015}} \times 100 = 110 \dots \dots \dots (2)$$

$$(1) \div (2): \frac{Q_{2015}}{Q_{2010}} = \frac{176}{110}$$

$$\begin{aligned} I &= \frac{Q_{2015}}{Q_{2010}} \times 100 \\ &= \frac{176}{110} \times 100 \\ &= 160 \end{aligned}$$

**Kaedah Alternatif /
Alternative method**

$$I_{\frac{2018}{2015}} = \frac{I_{\frac{2018}{2010}}}{\frac{I_{\frac{2015}{2010}}}{176}} \times 100$$

$$110 = \frac{I_{\frac{2018}{2010}}}{176} \times 100$$

$$\begin{aligned} I_{\frac{2018}{2010}} &= \frac{176}{110} \times 100 \\ &= 160 \end{aligned}$$

- 1) Nombor indeks yang menunjukkan perubahan bilangan murid sekolah rendah yang memakai cermin mata pada tahun 2014 berasaskan tahun 2010 dan 2012 masing – masing ialah 161 dan 140. Cari nombor indeks bagi bilangan murid pada tahun 2012 berasaskan tahun 2010.

The index numbers that show the change in the number of primary students who wore spectacles in the year 2014 based on the year 2010 and 2012 were 161 and 140 respectively. Find the index number of the number of students in the year 2012 based on the year 2010.

- 2) Indeks harga bagi sebuah kereta pada tahun 2019 berasaskan tahun 2010 dan 2015 masing – masing ialah 150 dan 125. Cari indeks harga bagi kereta tersebut pada tahun 2015 berasaskan tahun 2010.

The price indices of a car in the year 2019 based on the year 2010 and 2015 were 150 and 125 respectively. Find the price index of the car in the year 2015 based on the year 2010.

120

- 3) Indeks harga bagi suatu barangan elektrik pada tahun 2004 dan 2006 berasaskan tahun 2000 masing – masing ialah 116 dan 125. Hitung indeks harga barangan elektrik itu pada tahun 2000 dan 2004 jika tahun 2006 digunakan sebagai tahun asas.

Price indices for a certain electric product in the year 2004 and 2006 based on the year 2000 were 116 and 125 respectively. Calculate the price indices in the year 2000 and 2004 if the year 2006 is used as base year.

80,92.8

- 4) Nombor indeks bagi semangkuk mi kari pada tahun 1996 berasaskan tahun 1990 ialah 140 dan nombor indeks bagi semangkuk mi kari pada tahun 2000 berasaskan tahun 1996 ialah 105. Cari indeks harga bagi semangkuk mi kari pada tahun 2000 berasaskan tahun 1990.

The price index for a bowl of curry mee in the year 1996 based on the year 1990 was 140 and the price index for a bowl of curry mee in the year 2000 based on the year 1996 was 105. Find the price index of a bowl of curry mee in the year 2000 based on the year 1990.

147

10.1.2 Menyelesaikan masalah yang melibatkan nombor indeks

10.1.2 Problem solving involving index number

1. Selesaikan setiap yang berikut.

TP 5

Solve each of the following.

CONTOH / EXAMPLE:

Indeks harga sejenis kasut sukan pada tahun 2009 dengan menggunakan tahun 2006 sebagai tahun asas ialah 130. Jika harga kasut sukan itu pada tahun 2006 ialah RM 80, cari harganya pada tahun 2009.

The price index of a sport shoes in the year 2009 by using the year 2006 as the base was 130. If the price of the sport shoes in the year 2006 was RM 80, find its price in the year 2009.

Jawapan / Answer:

Andaikan / Let:

Q_{2009} = harga kasut sukan pada tahun 2009/price of the sport shoes in 2009

Q_{2006} = harga kasut sukan pada tahun 2006/price of the sport shoes in 2006

$$\begin{aligned}\text{Indeks harga / price index, } I &= \frac{Q_{2009}}{Q_{2006}} \times 100 = 130 \\ &= \frac{Q_{2009}}{80} \times 100 = 130 \\ Q_{2009} &= \frac{130 \times 80}{100} \\ &= \text{RM } 104\end{aligned}$$

- a) Jadual di bawah menunjukkan harga bagi dua barangan A dan B pada tahun 2005 dan 2008.

The table shows the prices of two items A and B the years 2005 and 2008.

Barangan Item	Harga (RM) Price (RM)	
	2005	2008
A	3.50	4.90
B	6.00	8.10

Hitung indeks harga bagi A dan B pada tahun 2008 berasaskan tahun 2005.

Calculate the price indices of A and B in the year 2008 based on the year 2005.

A=140, B=135

- b) Jadual dibawah menunjukkan harga barangan P dan Q pada tahun 2015 dan 2017, dan indeks harga pada tahun 2017 berasaskan tahun 2015.
The table shows the prices of items P and Q in the years 2015 and 2017 and the price indices in the year 2017 based on the year 2015.

Barangan <i>Item</i>	Harga / <i>price</i> (RM)		Indeks harga pada tahun 2017 berasaskan tahun 2015 / <i>price</i> <i>index in the year 2017 based on</i> <i>the year 2015.</i>
	2015	2017	
P	x	360	125
Q	125	y	140

Cari nilai bagi x dan y . / Find the values of x and y .

$$x=288, y = 175$$

- c) Jadual di bawah menunjukkan harga per kg bagi barangan A, B dan C pada tahun 2008 dan 2009 dan indeks harga pada tahun 2009 berasaskan tahun 2008.

Barangan <i>Item</i>	Harga / <i>price</i> (RM)		Indeks harga pada tahun 2009 berasaskan tahun 2008 / <i>price</i> <i>index in the year 2009 based on</i> <i>the year 2008.</i>
	2008	2009	
A	RM 1.20	RM 1.60	z
B	x	RM 2.31	110
C	RM 0.60	y	105

Cari nilai bagi x , y dan z . / Find the values of x , y and z .

$$x=2.10, y=0.63, z=133.33$$

- d) Jadual di bawah menunjukkan indeks harga bagi dua barangan A dan B. Cari nilai bagi x dan y .
The table shows the price indices of two items A and B. Find the values of x and y .

Barangan <i>Item</i>	Indeks harga / <i>price index</i>		
	2008 (2005 = 100)	2010 (2005 = 100)	2010 (2008 = 100)
A	120	150	x
B	110	y	140

$$x = 125, y = 154$$

- e) Indeks harga bagi dua jenis emas untk tahun – tahun tertentu diberi dalam jadual berikut.
Price indices of two types of gold for certain years are given in the following table.

Jenis Emas <i>Type of gold</i>	Indeks harga / <i>price index</i>		
	2016 (2002 = 100)	2018 (2002 = 100)	2018 (2016 = 100)
A	125	140	x
B	135	y	120

Hitung nilai bagi x dan nilai bagi y .
Calculate the value of x and y .

$$x = 112, y = 162$$

LATIHAN INTENSIF / INTENSIVE PRACTICE

- 1) Pada bulan Januari 2017, purata suhu di bandar P ialah 25.3°C manakala purata suhu pada bulan Februari 2017 ialah 27.4°C . Cari indeks purata suhu pada bulan Februari dengan mengambil bulan Januari sebagai masa asas dan tafsirkan nombor indeks yang diperoleh.
In January 2017, the average temperature in town P was 25.3°C whereas the average temperature in February 2017 was 27.4°C . Find the average temperature index in February with January as the base time and interpret the index number obtained.

108.3

- 2) Diberi indeks harga bagi sejenis item pada tahun 2016 berasaskan tahun 2015 ialah 130 dan indeks harga pada tahun 2016 berasaskan tahun 2012 ialah 120. Cari indeks harga item tersebut pada tahun 2015 berasaskan tahun 2012 dan tafsirkan.
Given the price index of a certain item in the year 2016 based on the year 2015 was 130 and the price index in the year 2016 based on the year 2012 was 120. Find the price index of this item in the year 2015 based on the year 2012 and interpret it.

92.31

- 3) Jadual di bawah menunjukkan harga dan indeks harga bagi tiga jenis bahan P, Q dan R yang digunakan untuk membuat sejenis biskut.

The table below shows the prices and the price indices of three ingredients P, Q, and R which are used in preparing a type of biscuit.

Bahan <i>Materials</i>	Harga (RM/kg) <i>Cost (RM/kg)</i>		Indeks harga pada tahun 2019 berdasarkan tahun 2015. <i>Price index in the year 2019 based on the year 2015.</i>
	Tahun 2015 <i>Year 2015</i>	Tahun 2019 <i>Year 2019</i>	
P	x	0.40	80
Q	2.00	y	140
R	0.80	1.00	z

Cari nilai – nilai x, y dan z.

Find the values of x, y and z

$$x = 0.5, y = 2.80, z = 12.5$$

- 4) Jadual di bawah menunjukkan harga runcit seekor ayam pada bulan Januari bagi tahun 2015 hingga 2018.

The table below shows the retail prices of a chicken in January for the year 2015 until 2018.

Tahun <i>Year</i>	Harga (RM/kg) <i>Price (RM/kg)</i>	Indeks harga <i>Price index</i>
2015	5.80	p
2016	7.65	q
2017	7.80	r
2018	7.30	s

Dengan mengambil tahun 2015 sebagai tahun asas, cari nilai bagi p, q, r dan s.

Using the year 2015 as the base year, find the value of p, q, r and s.

$$p = 100, r = 134.48, q = 131.90, s = 125.86$$

- 5) Jadual di bawah menunjukkan indeks harga bagi sejenis makanan pada tahun 2015 dan 2018 berdasarkan tahun 2010.

The diagram below shows the price index for a type of food in 2015 and 2018 based on the year 2010.

Item	Indeks harga <i>Price index</i>	
	Tahun 2015 <i>Year 2015</i>	Tahun 2018 <i>Year 2018</i>
Makanan / <i>Food</i>	110	118

Cari indeks harga bagi makanan itu pada tahun 2018 berdasarkan tahun 2015.

Find the price index of the food in the year 2018 based on the year 2015.

107.27

10.2 Indeks Gubahan / **Composite Index**

10.2.1 **Menentukan dan mentafsirkan indeks gubahan**

10.2.1 **Determining and interpreting composite index**

Nota Ringkas / Smart Notes

- ✚ **Pemberat** yang diberikan pada suatu item mewakili kepentingan item tersebut berbanding dengan item – item lain yang terlibat.

*The **weightage** assigned to an item represents the importance of this item compared to other items involved.*

- ✚ **Indeks Gubahan, \bar{I}** , ialah nilai purata bagi semua nombor indeks dengan kepentingan setiap item diambil kira.

*The **composite index, \bar{I}** , is the average value of all the index numbers with the importance of each item is taken into account.*

$$\bar{I} = \frac{\sum I_i W_i}{\sum W_i}$$

Dengan keadaan / *where*

I_i = nombor indeks bagi item ke -i / index number of the i^{th} term.

W_i = Pemberat bagi item ke -i / weightage of the i^{th} term.

- ✚ Bagi indeks gubahan tanpa pemberat, nilai pemberat setiap nombor indeks yang terlibat dianggap sama.

For the composite index without the weightage, the weightage for each index number involved is considered to be the same.

TP 2

1. Hitungkan indeks gubahan dengan pemberat dan tanpa pemberat.
Calculate the composite index with and without the weightage.

CONTOH 1 / EXAMPLE 1:

Indeks harga satu kilogram bagi tiga jenis buah – buahan yang dijual di sebuah gerai pada tahun 2018 berasaskan tahun 2010 masing – masing ialah 175, 120 dan 160. Cari indeks gubahan bagi buah – buahan tersebut pada tahun 2018 berasaskan tahun 2010.

Price index of one kilogram of three types of fruits sold in a stall in the year 2018 based on the year 2010 was 175, 120 and 160 respectively. Find the composite index of these fruits in the year 2018 based on the year 2010.

JAWAPAN / ANSWER:

$$\text{Indeks gubahan, } \bar{I} = \frac{\sum I_i w_i}{\sum w_i}$$

$$\text{Composite Index, } \bar{I} = \frac{175(1)+120(1)+160(1)}{3}$$

$$= 151.67$$

Tanpa pemberat /
Without weightage

CONTOH 2 / EXAMPLE 2:

Jadual di bawah menunjukkan indeks perbelanjaan utility sebuah kilang pada tahun 2017 berasaskan tahun 2011. Carta pai pula menunjukkan peratus penggunaannya dalam sebulan.

The table below shows the expenditure of utility index of a factory in the year 2017 based on the year 2011. The pie chart shows the percentages of the usage in a month.

Utiliti / Utility	Indeks perbelanjaan / Expenditure index
Air / Water	135
Elektrik / Electric	140
Bahan api / Fuel	125

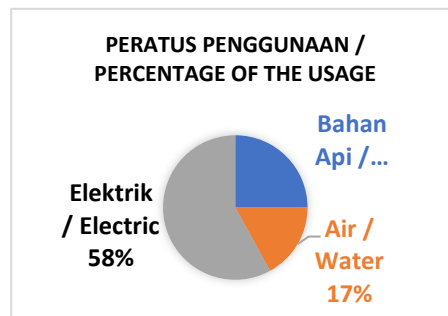

Cari indeks gubahan perbelanjaan utility pada tahun 2017 berasaskan tahun 2011.

Find the composite index of the expenditure of utility in the year 2017 based on the year 2011.

JAWAPAN / ANSWER:

$$\text{Indeks gubahan, } \bar{I} = \frac{\sum I_i w_i}{\sum w_i}$$

$$= \frac{135(17)+140(58)+125(25)}{17+58+25}$$

$$= \frac{13\ 540}{100}$$

$$= 135.4$$

Dengan pemberat /
With weightage

<p>a)</p> <table border="1"> <thead> <tr> <th>Barangan / Item</th> <th>Indeks harga / Price Index</th> </tr> </thead> <tbody> <tr> <td>A</td> <td>120</td> </tr> <tr> <td>B</td> <td>110</td> </tr> <tr> <td>C</td> <td>115</td> </tr> </tbody> </table> <p style="text-align: right;">115</p>	Barangan / Item	Indeks harga / Price Index	A	120	B	110	C	115	<p>b)</p> <table border="1"> <thead> <tr> <th>Barangan / Item</th> <th>Indeks harga / Price index</th> <th>Pemberat / Weightage</th> </tr> </thead> <tbody> <tr> <td>P</td> <td>120</td> <td>50</td> </tr> <tr> <td>Q</td> <td>110</td> <td>40</td> </tr> <tr> <td>R</td> <td>125</td> <td>50</td> </tr> <tr> <td>S</td> <td>115</td> <td>60</td> </tr> </tbody> </table> <p style="text-align: right;">117.75</p>	Barangan / Item	Indeks harga / Price index	Pemberat / Weightage	P	120	50	Q	110	40	R	125	50	S	115	60		
Barangan / Item	Indeks harga / Price Index																									
A	120																									
B	110																									
C	115																									
Barangan / Item	Indeks harga / Price index	Pemberat / Weightage																								
P	120	50																								
Q	110	40																								
R	125	50																								
S	115	60																								
<p>c)</p> <table border="1"> <thead> <tr> <th>Barangan / Item</th> <th>Indeks harga / Price Index</th> </tr> </thead> <tbody> <tr> <td>E</td> <td>124</td> </tr> <tr> <td>F</td> <td>140</td> </tr> <tr> <td>G</td> <td>132</td> </tr> <tr> <td>H</td> <td>116</td> </tr> </tbody> </table> <p style="text-align: right;">128</p>	Barangan / Item	Indeks harga / Price Index	E	124	F	140	G	132	H	116	<p>d)</p> <table border="1"> <thead> <tr> <th>Barangan / Item</th> <th>Indeks harga / Price index</th> <th>Pemberat / Weightage</th> </tr> </thead> <tbody> <tr> <td>J</td> <td>120</td> <td>2</td> </tr> <tr> <td>K</td> <td>95</td> <td>8</td> </tr> <tr> <td>L</td> <td>110</td> <td>6</td> </tr> <tr> <td>M</td> <td>140</td> <td>4</td> </tr> </tbody> </table> <p style="text-align: right;">111</p>	Barangan / Item	Indeks harga / Price index	Pemberat / Weightage	J	120	2	K	95	8	L	110	6	M	140	4
Barangan / Item	Indeks harga / Price Index																									
E	124																									
F	140																									
G	132																									
H	116																									
Barangan / Item	Indeks harga / Price index	Pemberat / Weightage																								
J	120	2																								
K	95	8																								
L	110	6																								
M	140	4																								

TP 3

2. Selesaikan setiap yang berikut.
Solve each of the following.

CONTOH / EXAMPLE:

Jadual di bawah menunjukkan indeks harga bagi empat barangan pada tahun 2018 berasaskan tahun 2014 dan pemberatnya masing – masing. Hitung indeks gubahan pada tahun 2018 berasaskan tahun 2014.

The table shows the price indices of four items in the year 2018 based on the year 2014 and their respective weightage. Calculate the composite index in the year 2018 based on the year 2014.

Barangan / Item	Indeks harga / Price Index	Pemberat / Weightage
A	112.5	20
B	105	30
C	108	10
D	120	40

$$\begin{aligned} \bar{I} &= \frac{112.5(20) + 105(30) + 108(10) + 120(40)}{20 + 30 + 10 + 40} \\ &= \frac{11\,280}{100} \\ &= 112.8 \end{aligned}$$

- a) Jadual di bawah menunjukkan indeks harga bagi tiga barangan pada tahun 2018 berasaskan tahun 2014 dan pemberatnya masing – masing. Hitung indeks gubahan pada tahun 2018 berasaskan tahun 2014.

The table below shows the price indices of three items in the year 2018 based on the year 2014 and their respective weightage. Calculate the composite index in the year 2018 based on the year 2014.

Barangan / Item	Indeks harga / Price Index	Pemberat / Weightage
P	100	4
Q	120	2
R	145	4

- b) Jadual menunjukkan indeks harga bagi empat jenis bahan pada tahun 1997 berasaskan tahun 1994. Hitung indeks gubahan bagi bahan – bahan tersebut pada tahun 1997 berasaskan tahun 1994.

The table shows the price indices of four types of ingredients in the year 1997 based on the year 1994. Calculate the composite index of the ingredients in the year 1997 based on the year 1994.

Bahan / Ingredient	Indeks harga pada tahun 1997 berasaskan tahun 1994 / Price index in the year 1997 based on the year 1994
A	128
B	110
C	125
D	90

113.25

- c) Jadual menunjukkan harga bagi empat komponen pada tahun 2000 dan tahun 2004 serta pemberatnya masing – masing. Hitung indeks gubahan pada tahun 2004 berasaskan tahun 2000.

The table shows the prices of four components in the years 2000 and 2004, and their respective weightage. Calculate the composite index in the year 2004 based on the year 2000.

Komponen / Component	Harga / Price (RM)		Pemberat / Weightage
	2000	2004	
E	70	105	4
F	40	36	2
G	50	60	6
H	100	125	3

Komponen / Component	Indeks harga pada tahun 2004 berasaskan tahun 2000 / Price index in the year 2004 based on the year 2000
E	
F	
G	
H	

125

- d) Jadual menunjukkan harga bagi empat jenis makanan pada tahun 2002 dan tahun 2007. Carta pai pula menunjukkan pemberat bagi setiap jenis makanan. *The table shows the prices of four types of food in the years 2002 and 2007. The pie chart shows the weightage for each type of food.*

Komponen / Component	Harga / Price (RM)	
	2000	2004
E	70	105
F	40	36
G	50	60
H	100	125

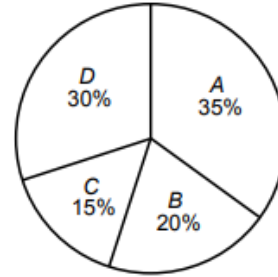

Hitung indeks gubahan pada tahun 2007 berasaskan tahun 2002.
Calculate the composite index in the year 2007 based on the year 2002.

Makanan / Food	Indeks harga pada tahun 2007 berasaskan tahun 2002 / Price index in the year 2007 based on the year 2002
A	
B	
C	
D	

10.2.2 Menyelesaikan masalah melibatkan nombor indeks dan indeks gubahan.

10.2.2 Solving problem involving index numbers and composite numbers.

1. Selesaikan soalan – soalan yang berikut.
Solve the following questions.



CONTOH / EXAMPLE:

Jadual menunjukkan indeks harga bagi tiga barangan pada tahun 1999 berasaskan tahun 1996 dan pemberatnya masing – masing. Diberi indeks gubahan pada tahun 1999 berasaskan tahun 1996 ialah 116. Cari nilai x.

Barangan / Item	Indeks harga / Price index	Pemberat / Weightage
P	125	5
Q	x	3
R	110	2

The table shows the price indices of three items in the year 1999 based on the year 1996 and their respective weightage. Given the composite index in the year 1999 based on the year 1996 is 116. Find the value of x.

JAWAPAN / ANSWER:

$$\frac{125(5) + x(3) + 110(2)}{5 + 3 + 2} = 116$$

$$\frac{3x + 845}{10} = 116$$

$$3x + 845 = 1160$$

$$3x = 315$$

$$x = 105$$

- a) Jadual menunjukkan indeks harga bagi empat jenis alat tulis pada tahun 2008 berasaskan tahun 2007 dan pemberatnya masing – masing. Diberi indeks gubahan pada tahun 2008 berasaskan tahun 2007 ialah 114.6, cari nilai x.

The table shows the price indices of four types of stationery in the year 2008 based on the year 2007 and their respective weightage. Given the composite index in the year 2008 based on the year 2007 was 114.6, find the value of x.

Alat Tulis Stationery	Indeks harga Price index	Pemberat Weightage
K	x	1
L	120	2
M	130	3
N	114	4

- b) Jadual menunjukkan indeks harga dan pemberat bagi empat jenis buah – buahan pada tahun 2015 berdasarkan tahun 2011. Indeks gubahan bagi empat jenis buah – buahan tersebut pada tahun 2015 berdasarkan tahun 2011 ialah 119. Cari nilai x .

The table shows the price indices and the weightage of four types of fruit in the year 2015 based on the year 2011. The composite index of all the four types of fruits in the year 2015 based on the year 2011 was 119. Find the value of x .

Buah – buahan <i>Fruits</i>	Indeks harga <i>Price index</i>	Pemberat <i>Weightage</i>
Tembikai / <i>Watermelon</i>	112	4
Betik / <i>Papaya</i>	130	1
Pisang / <i>Banana</i>	120	2
Nanas / <i>Pineapple</i>	x	3

2. Selesaikan setiap yang berikut
Solve each of the following.

Contoh / Example:

Jadual di bawah menunjukkan indeks harga bagi empat barangan pada tahun 2008 berdasarkan tahun 2004 dan pemberatnya masing – masing.

The table shows the price indices of four items in the year 2008 based on the year 2004 and their respective weightage.

Barangan / Item	Indeks harga / Price Index	Pemberat / Weightage
A	120	1
B	114	y
C	x	5
D	130	2

Harga bagi barangan C pada tahun 2004 dan tahun 2008 masing – masing ialah RM 30 dan RM 42. Diberi indeks gubahan pada tahun 2008 berdasarkan tahun 2004 ialah 128, cari nilai x dan nilai y.

The prices of item C in the year 2004 and the year 2008 were RM 30 and RM 42 respectively. Given the composite index in the year 2008 based on the year 2004 is 128, find the value of x and of y.

Jawapan / Answer:

$$\begin{aligned}
 x &= \frac{Q_{2008}}{Q_{2004}} \times 100 \\
 &= \frac{42}{30} \times 100 \\
 &= 140
 \end{aligned}$$

Indeks Gubahan / *Composite index, $\bar{I} = 128$*

$$\frac{120(1) + 114(y) + 140(5) + 130(2)}{1 + y + 5 + 2} = 128$$

$$\frac{114y + 1\ 080}{y + 8} = 128$$

$$114y + 1\ 080 = 128y + 1\ 024$$

$$14y = 56$$

$$y = 4$$

- a) Jadual di bawah menunjukkan indeks harga bagi tiga barangan pada tahun 2018 berasaskan tahun 2013 dan pembertanya masing – masing.
The table shows the price indices of three items in the year 2018 based on the year 2013 and their respective weightage.

Barangan / <i>Item</i>	Indeks harga / <i>Price Index</i>	Pemberat / <i>Weightage</i>
A	136	y
B	x	2
C	108	3

Harga barangan B pada tahun 2013 dan 2018 masing – masing ialah RM 30 dan RM 34.20. Indeks gubahan bagi tiga barangan itu pada tahun 2018 berasaskan tahun 2013 ialah 120. Cari nilai x dan y.
The prices of item B in the year 2013 and 2018 were RM 30 and RM 34.20 respectively. The composite index of the three items in the year 2018 based on the year 2013 was 120. Find the values of x and y.

$$x = 114, y = 3$$

- b) Jadual di bawah menunjukkan indeks harga bagi empat komponen yang digunakan untuk menghasilkan satu barang elektrik pada tahun 2006 berdasarkan tahun 2004 dan pemberatnya masing – masing.

The table below shows the price indices of four components used to produce an electric item in the year 2006 based on the year 2004 and their respective weightage.

Komponen <i>Component</i>	Harga/Price (RM)		Indeks harga pada tahun 2006 berdasarkan tahun 2004 <i>Price index in the year 2006 based on the year 2004</i>	Pemberat <i>Weightage</i>
	2004	2006		
Q	50	60	h	1
R	25	40	160	3
S	k	100	125	4
T	40	p	110	m

- (i) Cari nilai bagi h , k dan p .
Find the values of h , k and p .
- (ii) Diberi indeks gubahan bagi semua komponen tersebut pada tahun 2006 berdasarkan tahun 2004 ialah 132. Cari nilai m .
Given the composite index for all the components in the year 2006 based on the year 2004 is 132, find the value of m .

(i) $k = 80$, $h = 120$, $p = 44$ (ii) $m = 2$

c) Carta palang di bawah menunjukkan kos mingguan lima produk P, Q, R, S dan T bagi suatu syarikat pada tahun 1998. Jadual pula menunjukkan harga dan indeks harga bagi lima produk tersebut.

The bar chart shows the weekly cost for five products P, Q, R, S and T of a company in the year 1998. The table shows the prices and price indices for the five products.

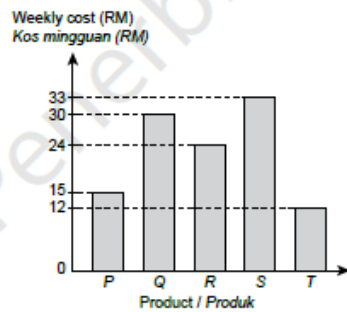

Product Produk	Price / Harga (RM)		Price index in the year 2013 based on the year 1998 <i>Indeks harga pada tahun 2013 berdasarkan tahun 1998</i>
	1998	2013	
P	x	0.70	175
Q	2.00	2.50	125
R	4.00	5.50	y
S	6.00	9.00	150
T	2.50	z	120

- (i) Cari nilai bagi x , y dan z .
Find the values of x , y and z .
- (ii) Cari indeks gubahan bagi lima produk tersebut pada tahun 2013 berasaskan tahun 1998.
Find the composite index for the five products in the year 2013 based on the year 1998.

(i) $x = 0.40$, $y = 137.5$, $z = 3$ (ii) 140.92

LATIHAN PENGUKUHAN / MASTERY PRACTICE

- 1) Jadual menunjukkan harga per kg bagi empat jenis bahan A, B, C dan D pada tahun 2017 dan 2019, indeks harga pada tahun 2019 berasaskan tahun 2017 dan pemberat masing – masing.

The table shows the price per kg of four types of goods, A, B, C and D in the year 2017 and 2019, price index in the year 2019 was based on the year 2017 and their weightages respectively.

Bahan Good	Harga pada tahun 2017 Price in the year 2017 (RM/kg)	Harga pada tahun 2019 Price in the year 2019 (RM/kg)	Indeks harga pada tahun 2019 Price index in the year 2019 (2017=100)	Pemberat Weightage
A	2.00	2.20	z	4
B	0.80	y	125	1
C	1.10	1.10	100	2
D	x	1.20	120	3

- a) Cari nilai – nilai bagi x, y dan z.

Find the value of x, y and z. [x=1.00, y=1.00, z=110]

- b) Hitung indeks gubahan bagi bahan – bahan tersebut pada tahun 2019 berasaskan tahun 2017.

Calculate the composite index of the goods in the year 2019 based on the year 2017. [112.5]

- 2) Jadual menunjukkan indeks harga bagi dua bahan A dan B yang digunakan untuk pengeluaran suatu jenis barang perhiasan rumah.

The table shows the price index of two materials A and B used in production of a type of household decorations.

Bahan Material	Indeks harga pada tahun 2018 berasaskan tahun 2016 Price index in the year 2018 based on the year 2016	Indeks harga pada tahun 2020 berasaskan tahun 2016 Price index in the year 2020 based on the year 2016
A	110	n
B	m	110

Diberi harga bagi Bahan B meningkat 22% pada tahun 2018 dari tahun 2016. Harga bahan A pada tahun 2016 ialah RM 5.00 dan harganya pada tahun 2020 ialah RM 6.05. cari nilai bagi m dan n.

Given the price of material B increased by 22% in the year 2018 from the year 2016. The price of material A in the year 2016 was RM 5.00 and the year 2020, RM 6.05. find the value of m and n. [m = 121, n = 122]

- 3) Jadual menunjukkan maklumat berkaitan empat bahan A, B, C dan D yang digunakan dalam pembuatan alat permainan. Peratus penggunaan bahan B tidak ditunjukkan.
The table shows the information related to four materials A, B, C and D used in making a toy. The percentage of usage of material B is not shown.

Bahan <i>Material</i>	Perubahan indeks harga dari tahun 2015 ke tahun 2018 <i>Change in price index from the year 2015 to the year 2018</i>	Peratus penggunaan (%) <i>Percentage usage (%)</i>
A	Menyusut 10% <i>Reduced 10%</i>	50
B	Menokok 60% <i>Increased 60%</i>	
C	Menokok 20% <i>Increased 20%</i>	10
D	Menokok 40% <i>Increased 40%</i>	10

Kos pengeluaran bagi alat permainan ini ialah RM 41 650 pada tahun 2018.

The production cost of the toy was RM 41 650 in the year 2018.

- a) Jika harga bahan C pada tahun 2015 ialah RM 7.60, cari harganya pada tahun 2018.
If the cost of material C in the year 2015 was RM 7.60, find the cost in the year 2018. [RM 9.12]
- b) Hitung kos pengeluaran yang sepadan pada tahun 2015.
Calculate the corresponding production cost in the year 2015. [35 000]
- c) Kos pengeluaran dijangka akan meningkat sebanyak 60% dari tahun 2018 ke tahun 2020. Hitung peratus perubahan dalam kos pengeluaran dari tahun 2015 ke tahun 2020.
The production cost is expected to increase by 60% from the year 2018 to the year 2020. Calculate the percentage change in the production cost from the year 2015 to the year 2020. [90.4%]
- 4) Pengeluaran getah di Malaysia ialah 1.126 juta tan pada tahun 2005, x juta tan pada tahun 2010 dan 0.722 juta tan pada tahun 2015. Hitung,
The rubber production in Malaysia is 1.126 million tonnes in 2005, x million tonnes in 2010 and 0.722 million tonnes in 2015. Calculate:
- a) Nombor indeks pengeluaran getah pada tahun 2015 berasaskan tahun 2005.
The index number for the rubber production in the year 2015 based on the year 2005. [64.12]
- b) Nilai x diberi nombor indeks pengeluaran getah pada tahun 2010 berasaskan tahun 2005 ialah 83.
The value of x , given that the index number for rubber production in the year 2010 based on the year 2005 is 83. [0.935 million tonne]
- c) Indeks pengeluaran getah pada tahun 2020 berasaskan tahun 2005 jika indeks pengeluaran getah pada tahun 2020 berasaskan tahun 2010 ialah 105.
The index for the rubber production in the year 2020 based on the year 2005 if the index for rubber production in the year 2020 based on the year 2010 is 105. [87.15]

- 5) Jadual menunjukkan harga bagi sejenis item pada tahun 2000 dan 2015.
The table shows the price for an item in 2000 and 2015.

Tahun <i>Year</i>	Harga <i>Price</i>
2000	RM 8
2015	RM 10

- a) Jika kadar kenaikan harga dari tahun 2015 ke tahun 2020 ialah dua kali ganda kadar kenaikan harga dari tahun 2000 ke tahun 2015, cari harga item tersebut pada tahun 2020.
If the rate of price increase from 2015 to 2020 is twice the rate of price increase from 2000 to 2015, determine the price of that item in 2020. [RM 15]
- b) Hitung indeks harga pada tahun 2020 berasaskan tahun 2000.
Calculate the price index in the year 2020 based on the year 2000. [187.5]
- 6) Jadual menunjukkan indeks harga dan pemberat bagi empat jenis bahan pada tahun 2020 berasaskan tahun 2019.
The table shows the price index and weightage for four types of materials in the year 2020 based on the year 2019.

Bahan <i>Materials</i>	Indeks harga <i>Price index</i>	Pemberat <i>Weightage</i>
P	107	2
Q	118	x
R	94	1
S	105	$2x$

- a) Indeks gubahan bagi bahan – bahan tersebut pada tahun 2020 berasaskan tahun 2019 ialah 108. Cari nilai x .
The composite index for the materials in the year 2020 based on the year 2019 is 108. Determine the value of x . [4]
- b) Indeks harga bagi bahan P meningkat sebanyak 20% dan indeks harga bagi bahan S menurun sebanyak 10% pada tahun 2020 hingga tahun 2021. Indeks harga bagi bahan lain tidak berubah. Cari indeks gubahan bagi bahan – bahan tersebut pada tahun 2021 berasaskan tahun 2019.
The price index for material P rises by 20% and the price index for material S drops by 10% in 2020 until 2021. The price index for other materials do not change. Determine the composite index for the materials in the year 2021 based on the year 2019. [105.25]

- 7) Jadual menunjukkan indeks jualan bagi ensiklopedia pada tahun 2015 dan 2017 menggunakan tahun 2000 sebagai tahun asas.
The table shows the sales index for an encyclopedia in 2015 and 2017 with the year 2000 as the base year.

Tahun / Year	2015	2017
Indeks Jualan / Sales Index	109	145

Cari indeks jualan bagi ensiklopedia itu pada tahun 2017 berasaskan tahun 2015.
Determine the sales index for the encyclopedia in the year 2017 based on the year 2015.
[133.03]

- 8) Jadual menunjukkan indeks harga bagi tiga jenis kamera.
The table shows the price index for three cameras.

Tahun Kamera	2013 (2011 = 100)	2019 (2011 = 100)	2019 (2013 = 100)
J	165	231	p
K	q	156	120
L	150	r	170

Cari nilai bagi p, q dan r.
Find the value of p, q and r. [p=140, q=130, r=255]

- 9) Berikut menunjukkan bilangan pelawat yang mengunjungi Pulau Langkawi pada tahun 2010 dan tahun 2017.
The following shows the number of visitors who visited Pulau Langkawi in 2010 and 2017.

2010	2.45 juta	2017	3.68 juta
------	-----------	------	-----------

- a) Cari bilangan pelawat pada tahun 2020 jika kadar kenaikan bilangan pelawat dari tahun 2017 ke tahun 2020 adalah dua kali ganda kadar kenaikan dari tahun 2010 ke tahun 2017.
Determine the number of visitors in 2020 if the rate of increase for the number of visitors in 2017 to 2020 is twice the rate of increase from 2010 to 2017. [6.14 million]
- b) Hitung indeks bilangan pelawat pada tahun 2020 berasaskan tahun 2017. Nyatakan tafsiran anda berkaitan nombor indeks yang diperoleh.
Calculate the index for number of visitors in the year 2020 based on the year 2017. State your interpretation based on the index number obtained. [166.85]

- 10) Jadual menunjukkan harga dan pemberat bagi tiga jenis bahan P, Q dan R pada tahun 2018 berasaskan tahun 2016.
The table shows the price and weightage for three materials P, Q and R in the year 2018 based on the year 2016.

Bahan / Material	P	Q	R
Indeks harga / Price Index	80	130	140
Pemberat / Weightage	x	y	z

Diberi indeks gubahan bagi bahan P dan Q pada tahun 2018 berasaskan tahun 2016 ialah 120 manakala bagi bahan P dan R ialah 125. Cari nisbah $x: y: z$.
Given the composite index for material P and Q in the year 2018 based on the year 2016 is 120 whereas the composite index for materials P and R is 125. Determine the ratio $x: y: z$. [1: 4: 3]

- 11) Indeks harga bagi topi keledar pada tahun 2014 berasaskan tahun 2010 ialah 80 dan indeks harga pada tahun 2018 berasaskan tahun 2014 ialah 110. Diberi harga topi keledar pada tahun 2018 ialah RM 166.
The price index for a safety helmet in the 2014 based on the year 2010 was 80 and the price index in the year 2018 based on the year 2014 was 110. Given the price for the safety helmet in the year 2018 was RM 166.

- Hitung harga topi keledar pada tahun 2010 dan tahun 2014.
Calculate the price of the safety helmet in 2010 and 2014. [RM188.64, RM150.91]
- Tentukan peratusan penurunan harga bagi topi keledar pada tahun 2010 berbanding dengan harganya pada tahun 2018.
Determine the percentage of decrease in price for safety helmets in 2010 compared to its price in 2018. [12%]

- 12) Harga bagi caj perkhidmatan di sebuah agensi pada tahun 2018 ialah RM 1.50. Jika harganya meningkat sebanyak 15% pada tahun 2019, hitung:
The price for service charge in an agency in 2018 was RM 150. If the price increased by 15% in 2019, calculate:

- Indeks harga bagi caj perkhidmatan pada tahun 2019 menggunakan tahun 2018 sebagai tahun asas.
The price index for service charge in 2019 with 2018 as the base year. [115]
- Harga bagi caj perkhidmatan tersebut pada tahun 2020 jika kadar kenaikan harga bagi tahun 2019 hingga tahun 2020 adalah sama dengan kadar kenaikan harga bagi tahun 2018 hingga tahun 2019.
The price for the service charge in 2020 if the rate of price increase in 2019 to 2020 in the same as the rate of price increase for 2018 to 2019. [RM 198.38]

PRAKTIS SPM / SPM PRACTICE

- 1) Jadual di bawah menunjukkan indeks harga dan perubahan indeks harga bagi empat bahan P, Q, R dan S yang digunakan untuk membuat sejenis kek. Rajah yang berikut adalah carta pai yang mewakili peratusan penggunaan bahan – bahan yang digunakan untuk membuat kek itu pada 2008.

The table shows the price indices and change in price indices of four ingredients P, Q, R and S which are used to make a type of cake. The diagram is a pie chart which represents the percentage of usage of the ingredients used to make the cake in 2008.

Ingredient Bahan	Price index in 2010 based on 2008 <i>Indeks harga pada 2010 berasaskan 2008</i>	Change in price index from 2010 to 2012 <i>Perubahan indeks harga dari 2010 ke 2012</i>
P	120	10% decrease <i>Menyusut 10%</i>
Q	108	No change <i>Tidak berubah</i>
R	125	No change <i>Tidak berubah</i>
S	150	10% increase <i>Menokok 10%</i>

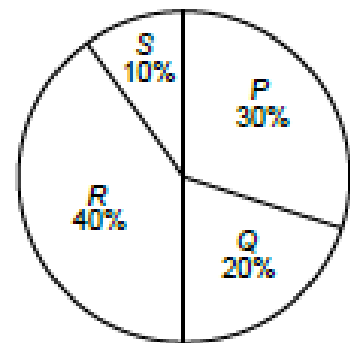

- a) Harga bahan P pada 2010 ialah RM 7.80. Cari harga yang sepadan pada tahun 2008.
The price of ingredient P in 2010 was RM 7.80. Find the corresponding price in 2008.
- [RM 6.50] [2m]
- b) Cari indeks harga bagi kesemua empat bahan itu pada 2012 berasaskan 2008.
Find the price indices of all the four ingredients in 2012 based on 2008. [108, 125, 165]
- [3m]
- c) (i) Hitung indeks gubahan bagi kos membuat kek itu pada 2012 berasaskan 2008.
Calculate the composite index for the cost of making the cake in 2012 based on 2008. [120.5]
- (ii) Seterusnya, cari kos membuat kek itu pada 2008 jika kos sepadan pada 2012 ialah RM 22.16.
Hence, find the cost of making the cake in 2008 if the corresponding cost in 2012 was RM 22.16. [RM18.39]

[5m]

- 2) Jadual menunjukkan indeks harga bagi tahun 2017 dan 2019 berasaskan tahun 2015 untuk tiga jenis bahan P, Q dan R yang digunakan untuk membuat sejenis pen.
The table shows the price indices in the years 2017 and 2019 based on the year 2015 of three materials P, Q and R used in making a type of pen.

Material Bahan	Price index in the year 2017 based on the year 2015 <i>Indeks harga pada tahun 2017 berasaskan tahun 2015</i>	Price index in the year 2019 based on the year 2015 <i>Indeks harga pada tahun 2019 berasaskan tahun 2015</i>
P	125	x
Q	120	132
R	130	156

- a) Harga bagi bahan P pada tahun 2015 ialah RM 14.00 dan harganya pada tahun 2019 ialah RM 24.50. Cari
The price of material P in the year 2015 was RM 14.00 and its price in the year 2019 was RM 24.50. Find
- (i) Nilai x
The value of x. [175]
- (ii) Harga bagi bahan P pada tahun 2017.
The price of material P in the year 2017. [RM17.50] [3m]
- b) Indeks gubahan untuk kos pengeluaran pen itu pada tahun 2017 berasaskan tahun 2015 ialah 125. Nisbah bahan – bahan P, Q, dan R yang digunakan ialah 1 : y : 3. Cari,
The composite index for the production cost of the pen in the year 2017 based on the year 2015 was 125. The ratio of materials P, Q and R used was 1 : y : 3. Find
- (i) Nilai y
The value of y. [3]
- (ii) Harga sepadan bagi pen itu pada tahun 2015 jika harga pen itu pada tahun 2017 ialah RM 44.50.
The corresponding price of the pen in the year 2015 if the price of the pen in the year 2017 was RM 44.50. [RM 35.60] [5m]
- c) Cari indeks harga bagi bahan R pada tahun 2019 berasaskan tahun 2017.
Find the price index of material R in the year 2019 based on the year 2017. [120] [2m]

- 3) Jadual di bawah menunjukkan harga dan indeks harga bagi tiga jenis bahan R, S dan T yang digunakan dalam penghasilan sejenis bebola daging.
The table shows the prices and the price indices of three types of ingredients R, S and T used in the production of a type of meat balls.

Ingredient Bahan	Price (RM) per kg Harga (RM) per kg		Price index in 2015 based on 2013 Indeks harga pada 2015 berasaskan 2013	Weightage Pemberat
	2013	2015		
R	4.00	6.00	150	60
S	q	2.16	p	30
T	0.80	1.00	125	10

- a) Harga bahan S menokok sebanyak 20% dari 2013 hingga 2015.
The price of ingredients S is increased by 20% from 2013 to 2015.
- (i) Nyatakan nilai p
State the value of p. [120]
- (ii) Cari nilai q.
Find the value of q. [1.80]
- [3m]
- b) Hitung indeks gubahan bagi kos membuat bebola daging pada 2015 berasaskan 2013
Calculate the composite index for the cost of making the meat balls in 2015 based on 2013. [138.5]
- [2m]
- c) Diberi bahawa indeks gubahan bagi kos membuat bebola daging meningkat sebanyak 50% dari 2011 hingga 2015.
It is given that the composite index for the cost of making meat balls increased by 50% from 2011 to 2015.
- (i) Hitung indeks gubahan bagi kos membuat bebola daging pada 2013 berasaskan 2011.
Calculate the composite index for the cost of making the meat balls in 2013 based on 2011. [108.3]
- (ii) Kos membuat sebiji bebola daging ialah 8 sen pada 2011. Cari bilangan maksimum bebola daging yang boleh dihasilkan menggunakan peruntukkan sebanyak RM 86 pada 2015.
The cost of making a meat ball was 8 sen in 2011. Find the maximum number of meat balls that can be produced using an allocation of RM 86 in 2015. [716]
- [5m]

- 4) Jadual di bawah menunjukkan maklumat berkaitan empat bahan K, L, M dan N yang digunakan dalam pembuatan sejenis roti.

The table shows the information related to four ingredients K, L, M and N used in the production of a type of bread.

Ingredient Bahan	Change in price index from 2010 to 2012 Perubahan indeks harga dari 2010 ke 2012	Percentage of usage (%) Peratus penggunaan (%)
K	20% increase Menokok 20%	10
L	10% decrease Menyusut 10%	30
M	40% increase Menokok 40%	
N	30% increase Menokok 30%	40

Kos pengeluaran bagi roti ini ialah RM 23 800 pada tahun 2013.

The production cost for this bread was RM 23 800 in the year 2012.

- a) Jika harga bahan N pada tahun 2010 ialah RM 3.60, cari harganya pada tahun 2012.
If the price of ingredient N in the year 2010 was RM 3.60, find its price in the year 2012.
[RM 4.68] [2m]
- b) Peratus penggunaan bagi beberapa bahan diberikan dalam jadual di atas. Hitung kos pengeluaran yang sepadan pada tahun 2010.
Percentage of usage for several ingredients were given in the table. Calculate the corresponding production cost in the year 2010. [RM 20 000] [5m]
- c) Kos pengeluaran dijangka meningkat sebanyak 25% dari tahun 2012 ke tahun 2015. Hitung peratus perubahan dalam kos pengeluaran dari tahun 2010 ke tahun 2015.
The production cost is expected to increase by 25% from the year 2012 to the year 2015. Calculate the percentage of changes in production cost from the year 2010 to the year 2015. [48.75% increase] [3]

- 5) Jadual di bawah menunjukkan indeks harga bagi tahun 2012 dan 2014 berasaskan tahun 2000 untuk tiga jenis bahan P, Q dan R yang digunakan untuk membuat sejenis beg tangan.
The table shows the price indices for the years 2012 and 2014 based on the year 2000 of three materials P, Q and R used in making a type of handbag.

Material Bahan	Price index in the year 2012 based on the year 2000 <i>Indeks harga pada tahun 2012 berasaskan tahun 2000</i>	Price index in the year 2014 based on the year 2000 <i>Indeks harga pada tahun 2014 berasaskan tahun 2000</i>	Weightage Pemberat
P	110	143	m
Q	120	h	3
R	125	115	2

- a) Harga bahan Q pada tahun 2000 ialah RM 14.00 dan harganya pada tahun 2014 ialah RM 16.10. Cari,
The price of material Q in the year 2000 was RM 14.00 and its price in the year 2014 was RM 16.10. Find,
- (i) Nilai h.
The value of h. [115]
- (ii) Harga bahan Q pada tahun 2012.
The price of material Q in the year 2012. [RM 16.80]
- [3m]
- b) Indeks gubahan bagi kos pengeluaran beg tangan itu pada tahun 2012 berasaskan tahun 2000 ialah 116. Cari,
The composite index for the production cost of the handbag in the year 2012 based on the year 2000 was 116. Find,
- (i) Nilai m
The value of m. [5]
- (ii) Harga sepadan bagi beg tangan itu pada tahun 2000 jika harga beg tangan itu pada tahun 2012 ialah RM 69.60.
The corresponding price of the handbag in the year 2000 if the price of the handbag in the year 2012 was RM 69.60. [RM 60]
- [4m]
- c) Cari indeks harga bagi bahan P pada tahun 2014 berasaskan tahun 2012.
Find the price index of material P for the year 2014 based on the year 2012. [130]
- [3m]

